

**User's Manual**

**THERMOCOUPLE  
INPUT MODULE**

A Series  
Programmable  
Controllers



**MITSUBISHI**

Cat. No. UMTD

## **INTRODUCTION**

Thank you for choosing the Mitsubishi MELSEC-A Series of General Purpose Programmable Controllers. Please read this manual carefully so that the equipment is used to its optimum. A copy of this manual should be forwarded to the end User.

**1. INTRODUCTION**

**2. SYSTEM CONFIGURATION**

**3. SPECIFICATIONS**

**4. PRE-OPERATION SETTINGS AND PROCEDURES**

**5. PROGRAMMING**

**6. ANALOG/DIGITAL CONVERSION FUNCTIONS**

**7. TROUBLESHOOTING**

**APPENDICES**

# CONTENTS

<b>1. INTRODUCTION</b> .....	1-1 ~ 1-3
1.1 Features .....	1-2
<b>2. SYSTEM CONFIGURATION</b> .....	2-1 ~ 2-5
2.1 Overall Configuration .....	2-1
2.2 Notes on Use of A616TD in System .....	2-3
2.3 Notes on Configuring a System .....	2-4
2.4 Module Connection .....	2-5
<b>3. SPECIFICATIONS</b> .....	3-1 ~ 3-16
3.1 General Specifications .....	3-1
3.2 Performance Specifications .....	3-2
3.2.1 Performance of the A616TD and A60MXT combination .....	3-2
3.2.2 Performance of the A616TD, A60MX and A60MXR combination .....	3-4
3.2.3 A616TD performance list .....	3-5
3.3 Temperature - Digital Conversion .....	3-6
3.3.1 Conversion characteristics .....	3-6
3.3.2 Conversion speed .....	3-7
3.3.3 Life of the mercury-plunger relays .....	3-8
3.3.4 Overall accuracy .....	3-8
3.3.5 Discontinuity detection function .....	3-9
3.3.6 Error compensation function .....	3-9
3.4 Analog/Digital Conversion .....	3-10
3.4.1 Conversion characteristics .....	3-10
3.4.2 Conversion speed .....	3-12
3.4.3 Overall Accuracy .....	3-13
3.5 Function Block Diagrams .....	3-14
3.5.1 Function block diagram of A616TD and A60MXT combination .....	3-14
3.5.2 A60MX function block diagram .....	3-15
3.5.3 A60MXR function block diagram .....	3-16
<b>4. PRE-OPERATION SETTINGS AND PROCEDURES</b> .....	4-1 ~ 4-11
4.1 Pre-Operation Settings and Procedures .....	4-1
4.2 Handling Instructions .....	4-2
4.3 Nomenclature .....	4-3
4.3.1 A616TD .....	4-3
4.3.2 A60MXT .....	4-5
4.4 Setting the A60MXT Measurement Range .....	4-6
4.5 Setting the Discontinuity Detection Channels .....	4-8
4.6 Wiring Instructions .....	4-9
4.7 Wiring Examples .....	4-10



<b>5. PROGRAMMING</b>	5-1 ~ 5-33
5.1 Programmable Controller CPU I/O List	5-1
5.2 Buffer Memory	5-4
5.2.1 Buffer memory assignment	5-4
5.3 Programming Procedure	5-5
5.4 Initial Setting	5-6
5.4.1 Setting the thermocouple types	5-7
5.4.2 Specifying A/D conversion enable/disable	5-9
5.4.3 Specifying the discontinuity detection channels	5-10
5.4.4 Setting the temperatures corresponding to digital output values	5-11
5.4.5 Set data setting request	5-14
5.5 Error Compensation Settings	5-16
5.6 Reading the Digital Output Values	5-19
5.7 Reading the Detected Temperature Values	5-21
5.8 Detected Temperature Value Celsius - Fahrenheit Conversion Program	5-23
5.9 External Fault Detection	5-24
5.9.1 Reading the faulty channel number	5-24
5.9.2 Reading the digital output value out-of-range channel number	5-25
5.9.3 Reading the detected temperature value out-of-range channel number	5-26
5.10 Reading the Current Sampling Period	5-27
5.11 Reading Error Codes	5-27
5.12 Clearing the Error Code Area	5-27
5.13 Programming for ACPU Remote I/O Station	5-28
5.13.1 Programming instructions	5-28
5.13.2 Basic programs for read and write	5-30
<b>6. ANALOG/DIGITAL CONVERSION FUNCTIONS</b>	6-1 ~ 6-14
6.1 Pre-Operation Settings and Procedures	6-1
6.1.1 Pre-operation settings and procedures	6-1
6.1.2 Description and settings of A60MX parts	6-2
6.1.3 Description and settings of A60MXR parts	6-4
6.1.4 Offset/Gain microadjustment	6-6
6.1.5 Offset microadjustment	6-7
6.1.6 Gain microadjustment	6-7
6.1.7 Wiring instructions	6-8
6.2 Programming Procedure	6-10
6.2.1 Initial setting	6-10
6.2.2 Reading the digital output values	6-12
6.2.3 Reading error codes	6-14
6.2.4 Clearing the error code area	6-14

<b>7. TROUBLESHOOTING</b>	7-1 ~ 7-26
7.1 Error Code List	7-1
7.2 Troubleshooting	7-2
7.2.1 General troubleshooting	7-2
7.2.2 "RUN" LED flickering	7-4
7.2.3 "RUN" LED off	7-5
7.2.4 Error code in special register D9008	7-7
7.2.5 CPU module "SP. UNIT DOWN" error	7-8
7.2.6 CPU module "SP. UNIT ERROR" error	7-8
7.2.7 CPU module "CONTROL-BUS ERROR" error	7-8
7.2.8 CPU unable to read digital output value	7-9
7.2.9 Watch-dog timer (WDT) error signal (X0) on	7-13
7.2.10 READY signal (X1) remains off	7-13
7.2.11 Discontinuity error detected (X3) or detected temperature output value out-of-range (X5) signal on	7-14
7.2.12 Digital output value out-of-range signal (X4) on	7-16
7.2.13 Detected temperature value not indicated if detected temperature value LED display request signal (Y10) turns on	7-16
7.2.14 Rapid fluctuations of digital output value or detected temperature value during temperature sensor input	7-17
7.2.15 Digital output value fluctuates rapidly during analog input	7-18
7.2.16 Error code indicated on LED display	7-19
7.2.17 No correlation between temperature sensor input value and digital output value	7-21
7.2.18 No correlation between analog input value and digital output value	7-23
7.2.19 Constant digital output value deviation from reference value during temperature sensor input	7-24
7.2.20 Constant digital output value deviation from reference value during analog input	7-25
7.2.21 Error compensation is abnormal	7-26
<b>APPENDICES</b>	APP-1 ~ APP-35
Appendix 1 Thermocouple Normal and Overheat Temperature Limits	APP-1
Appendix 2 Temperature Tolerances	APP-1
Appendix 3 Thermoelectromotive Force Tables	APP-2
3.1 Standard thermoelectromotive force tables for type B thermocouples	APP-2
3.2 Standard thermoelectromotive force tables for type R thermocouples	APP-6
3.3 Standard thermoelectromotive force tables for type S thermocouples	APP-10
3.4 Standard thermoelectromotive force tables for type K thermocouples	APP-14
3.5 Standard thermoelectromotive force tables for type E thermocouples	APP-18

3.6	Standard thermoelectromotive force tables for type J thermocouples .....	APP-21
3.7	Standard thermoelectromotive force tables for type T thermocouples .....	APP-25
3.8	Standard thermoelectromotive force tables for type Fe-CuNi thermocouples .....	APP-27
3.9	Standard thermoelectromotive force tables for type Cu-CuNi thermocouples .....	APP-31
Appendix 4	A616TD Dimensions .....	APP-33
Appendix 5	A60MXT Dimensions .....	APP-34
Appendix 6	A60MX/A60MXR Dimensions .....	APP-35



# 1. INTRODUCTION

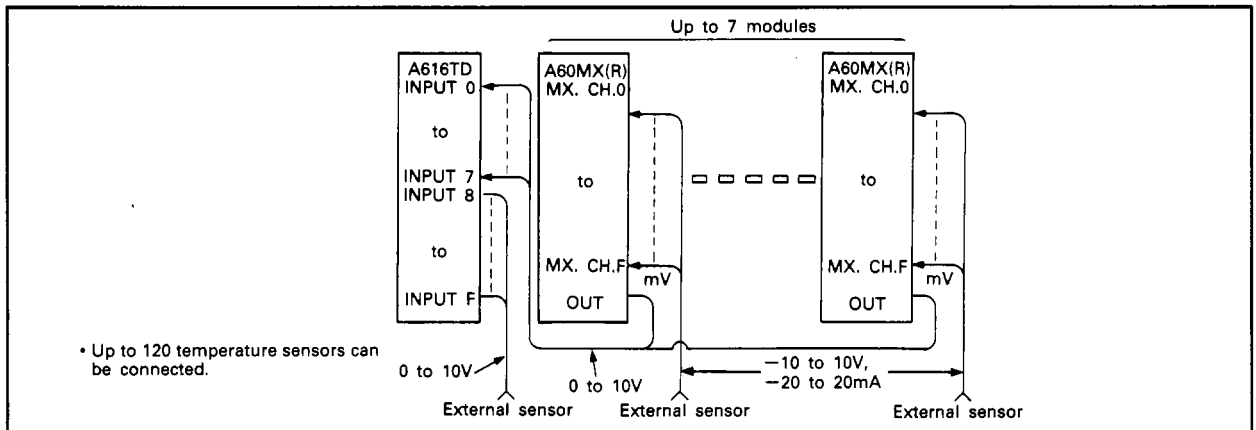

Fig. 1.3 A616TD+A60MX(A60MXR) Combination

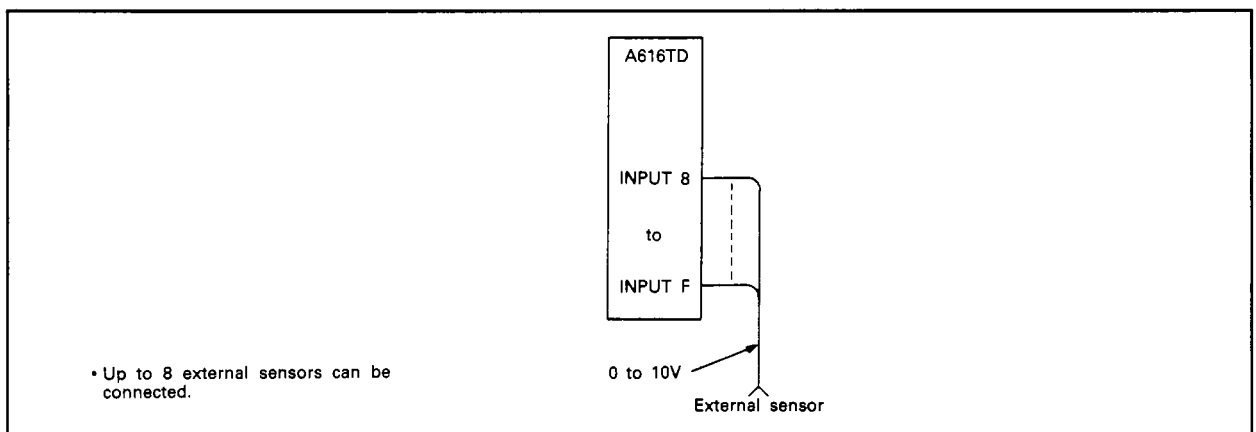

Fig. 1.3 A616TD Stand-Alone Operation

## 1.1 Features

- (1) A maximum of seven A60MX modules can be connected to A616TD channels 0 to 7. Up to 105 temperature sensors (thermocouples) can be connected if all seven of the modules are of the A60MXT type. Alternatively, if all of the modules are of the A60MX and/or A60MXR type, a total of up to 120 external sensors can be connected.
- (2) A total of 420 temperature sensors can be connected if A616TD-A60MXT combinations are installed in all 64 slots available with the maximum configuration of a single-CPU stand-alone system. Using A616TD-A60MX or A60MXR combinations, up to 960 external sensors can be connected.
- (3) The A60MXT permits the connection of thermocouples meeting four different Japanese and overseas standards: JIS, ANSI, DIN and BS.
- (4) The thermoresistor (PT100) connected to channel 0 of the A60MXT automatically carries out cold-junction compensation.
- (5) Wiring discontinuity detection settings and error compensation can be enabled for each A60MXT channel.

# 1. INTRODUCTION

---

The following abbreviations are used for various types of CPU in this User's Manual.

(1) Sequencer CPU

A1(E)CPU(P21/R21), A1NCP(U)(P21/R21),  
A2(E)CPU(P21/R21), A2NCP(U)(P21/R21)  
A3(E)CPU(P21/R21), A3NCP(U)(P21/R21), A3HCP(U)(P21/R21)  
A0J2CPU(P23/R23)

(2) Building-block type CPU

A1(E)CPU(P21/R21), A1NCP(U)(P21/R21),  
A2(E)CPU(P21/R21), A2NCP(U)(P21/R21)  
A3(E)CPU(P21/R21), A3NCP(U)(P21/R21), A3HCP(U)(P21/R21)

(3) Compact-type CPU

A0J2CPU(P23/R23)

## 2. SYSTEM CONFIGURATION

### 2. SYSTEM CONFIGURATION

#### 2.1 Overall Configuration

(1) System using the A616TD with building block type CPU

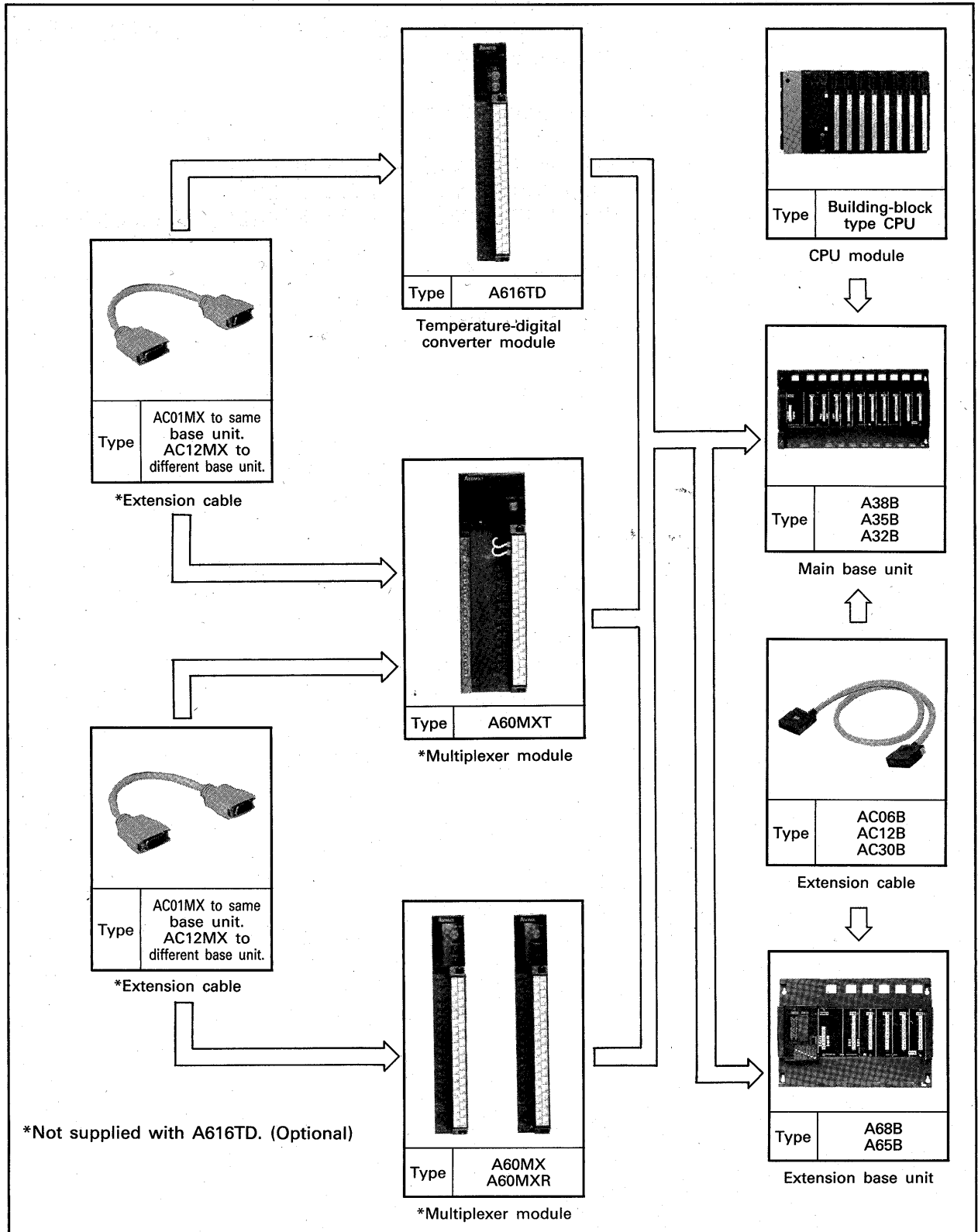

## 2. SYSTEM CONFIGURATION

### (2) System using the A616TD with compact CPU

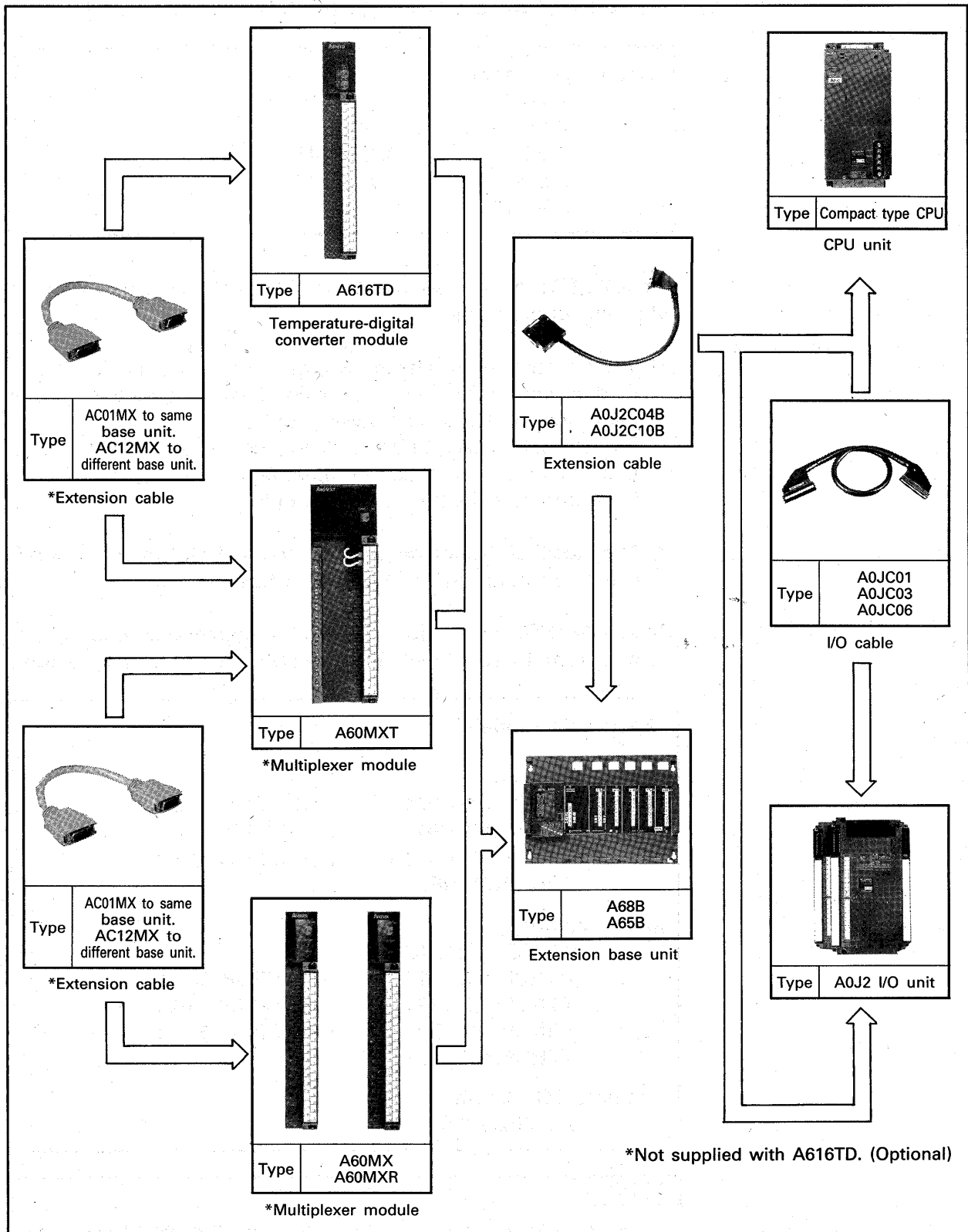



## 2. SYSTEM CONFIGURATION

### 2.2 Notes on Use of A616TD in System

The A616TD can be used with the following CPU modules:

Applicable models	
A0J2CPU	
A1NCPU	A1(E)CPU
A2NCPU	A2(E)CPU
A3NCPU	A3(E)CPU
A3HCPU	

The A616TD may be loaded onto any slot of the base unit with the following precautions:

- (1) The power supply capacity will be exceeded if the A616TD is loaded into an A5[ ] type extension base unit, as this type of base unit contains no power supply.  
Therefore, if the A616TD is to be loaded into an extension base unit, the extension base unit must be of the A6[ ] type which incorporates a built-in power supply.
- (2) The A616TD cannot be used on the last slot of the seventh extension stage in an A3CPU(P21/R21) system.
- (3) The A616TD may be loaded onto the master station or a local or a remote I/O station in a MELSECNET data link system.

Applicable models	
(Master station)	
A1NCPUP21/R21	A1(E)CPUP21/R21
A2NCPUP21/R21	A2(E)CPUP21/R21
A3NCPUP21/R21	A3(E)CPUP21/R21
A3HCPUP21/R21	
(Local station)	
A0J2CPUP23/R23	
A1NCPUP21/R21	A1(E)CPUP21/R21
A2NCPUP21/R21	A2(E)CPUP21/R21
A3NCPUP21/R21	A3(E)CPUP21/R21
A3HCPUP21/R21	
(Remote I/O station)	
AJ72P25/R25	

#### POINT

**The A616TD cannot be used on the A0J2P25/R25 (remote I/O station)**

## 2. SYSTEM CONFIGURATION

### 2.3 Notes on Configuring a System

- (1) Do not feed the input/output module into either of the pairs of slots to the left and right of the A60MXT.  
If the input/output module is loaded into these slots, the noise it generates may prevent stable temperature measurements.

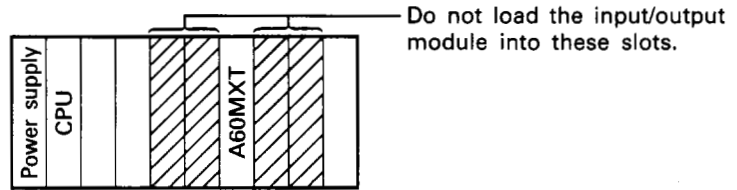

- (2) Up to seven modules may be loaded by connecting the OUT terminal of the A60MX[ ] with any of the A616TD INPUT channels 0 to 7.  
The A60MX[ ] cannot be used independently.
- (3) External sensors cannot be connected directly to any of the eight A616TD INPUT channels 0 to 7.
- (4) A special extension cable, ACO1MX, is required to connect the A616TD to an A60MX[ ] module.  
A special extension cable, AC12MX, is required to connect the A616TD to another base unit. Only an A60MX[ ] module may be loaded between an A616TD and another A60MX[ ] module, or between two A60MX[ ] modules on any one base unit. Always load the A616TD to the left of an A60MX[ ] module.
- (5) The A616TD A/D conversion characteristics fixed to convert an analog input of 0 to 10V to the range 0 to 4000 or -2000 to 2000. These ranges cannot be changed by the user.  
An A60MX or A60MXR module must be loaded if connecting external sensors producing an analog input outside the range 0 to 10 V.
- (6) A60MXT channels are isolated from each other by means of mercury-plunger relays. Channels for which discontinuity detection is selected become non-isolated and are connected by means of the discontinuity detection circuit (resistance 20 M $\Omega$ ).
- (7) The A60MXT and A60MX are not isolated between channels but 1M $\Omega$  resistor isolation minimizes influence between the channels.
- (8) Discontinuity detection may not be enabled for channels to which tip-grounded thermocouples are connected.
- (9) The sampling period is set automatically according to the number of channels for which conversion is enabled. The sampling period cannot be specified by the user.
- (10) The A616TD may only be loaded to the first four slots of the extension base unit used with the A0J2CPU.
- (11) The life of the A60MXT channel-selector mercury-plunger relays is 900 million cycles. In order to increase the number of years of service life of the relays, increase the sampling period by enabling conversion for all channels.

## 2. SYSTEM CONFIGURATION

### 2.4 Module Connection

The configuration of the connection of A60MXT, A60MX or A60MXR modules to the A616TD are shown in the diagram below.

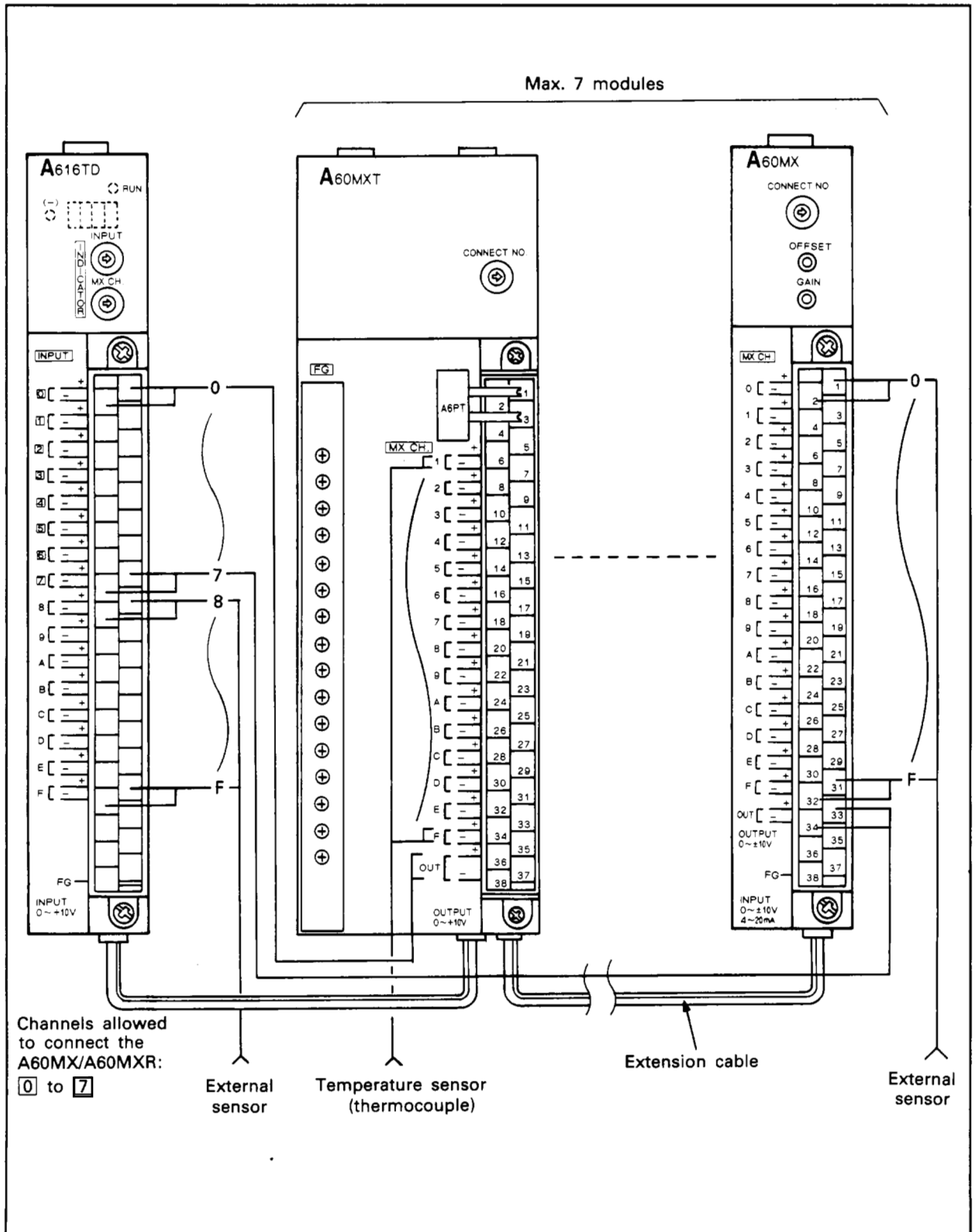

### 3. SPECIFICATIONS

#### 3. SPECIFICATIONS

##### 3.1 General Specifications

Table 3.1 shows the common specifications of various units used.

Item	Specifications				
Operating ambient temperature	0 to 55°C				
Storage ambient temperature	-20 to 75°C				
Operating ambient humidity	10 to 90%RH, non-condensing				
Storage ambient humidity	10 to 90%RH, non-condensing				
Vibration resistance	Conforms to *JIS C 0911	Frequency	Acceleration	Amplitude	Sweep Count
		10 to 55Hz	—	0.075mm	10 times
		55 to 150Hz	1g	—	*(1 octave/minute)
Shock resistance	Conforms to JIS C 0912 (10g × 3 times in 3 directions)				
Noise durability	By noise simulator of 1500Vpp noise voltage, 1 μs noise width and 25 to 60Hz noise frequency				
Dielectric withstand voltage	1500V AC for 1 minute across AC external terminals and ground 500V AC for 1 minute across DC external terminals and ground				
Insulation resistance	5MΩ or larger by 500V DC insulation resistance tester across AC external terminals and ground				
Grounding	Class 3 grounding; grounding is not required when it is impossible.				
Operating ambience	Free of corrosive gases. Dust should be minimal.				
Cooling method	Self-cooling				

**Table 3.1 General Specifications**

#### REMARKS

One octave marked \* indicates a change from the initial frequency to double or half frequency. For example, any of the changes from 10Hz to 20Hz, from 20Hz to 40Hz, from 40Hz to 20Hz, and 20Hz to 10Hz are referred to as one octave.

\*JIS: Japanese Industrial Standard

### 3. SPECIFICATIONS

#### 3.2 Performance Specifications

The performance specifications of the A616TD, A60MXT, A60MX and A60MXR modules are listed below.

##### 3.2.1 Performance of the A616TD and A60MXT combination

The performance specifications of the A616TD and A60MXT combination are listed in the table below.

Item		Specifications								Reference		
Temperature sensor input (°C)		-200 to 1800								—		
Output	Digital output values	Binary digital values (0 to 4000) with a 16-bit sign (12 data bits).								Section 3.3.1		
	Temperature output values	Binary digital values with a 16-bit sign (-2000 to 18000 : value to the first decimal place × 10)										
Acceptable thermocouples		Standard		Type or code						Appendices 1 to 3		
		JIS	B	R	S	K	E	J	T		—	—
		ANSI	B	R	S	K	E	J	T		—	—
		DIN	—	—	PtRh -Pt	NiCr -Ni	—	—	—		Fe -CuNi	Cu -CuNi
		BS	PtRh30 -PtRh6	PtRh13 -Pt	PtRh10 -Pt	NiCr -NiAl	NiCr -CuNi	Fe -CuNi	Cu -CuNi	—	—	
*1 Measurement temperature range accuracy		Measurement range no.				1	2	3	4	Section 4.4		
		JIS standard	ANSI standard	DIN standard	BS standard	Permitted input voltage range (mV)	-12.5 to 12.5	0 to 25	0 to 50		0 to 100	
		B	B	—	PtRh30 -PtRh6	Measurement temperature range (°C)	100 to 1500	100 to 1800	100 to 1800		100 to 1800	
						Accuracy (%)	—	±0.5	—		—	
						Temperature drift (°C)	—	±0.013	—		—	
		R	R	—	PtRh13 -Pt	Measurement temperature range (°C)	0 to 1000	0 to 1700	0 to 1700		0 to 1700	
						Accuracy (%)	—	±0.4	—		—	
						Temperature drift (°C)	—	±0.011	—		—	
		S	S	PtRh -Pt	PtRh10 -Pt	Measurement temperature range (°C)	0 to 1200	0 to 1700	0 to 1700		0 to 1700	
						Accuracy (%)	—	±0.4	—		—	
						Temperature drift (°C)	—	±0.011	—		—	
		K	K	NiCr -Ni	NiCr -NiAl	Measurement temperature range (°C)	-200 to 250	0 to 500	0 to 1000		0 to 1300	
						Accuracy (%)	±0.4	±0.3	±0.3		±0.5	
						Temperature drift (°C)	±0.011	±0.01	±0.01		±0.013	
		E	E	—	NiCr -CuNi	Measurement temperature range (°C)	-200 to 150	0 to 300	0 to 600		0 to 1000	
						Accuracy (%)	±0.4	±0.3	±0.3		±0.4	
						Temperature drift (°C)	±0.011	±0.01	±0.01		±0.011	
		J	J	—	Fe -CuNi	Measurement temperature range (°C)	-200 to 200	0 to 400	0 to 800		0 to 1200	
						Accuracy (%)	±0.4	±0.3	±0.3		±0.4	
Temperature drift (°C)	±0.011					±0.01	±0.01	±0.011				
T	T	—	Cu -CuNi	Measurement temperature range (°C)	-200 to 200	0 to 400	0 to 400	0 to 400				
				Accuracy (%)	±0.5	±0.3	—	—				
				Temperature drift (°C)	±0.013	±0.01	—	—				
—	—	Fe -CuNi	—	Measurement temperature range (°C)	-100 to 200	0 to 400	0 to 800	0 to 900				
				Accuracy (%)	—	±0.3	±0.3	±0.5				
				Temperature drift (°C)	—	±0.01	±0.01	±0.013				
—	—	Cu -CuNi	—	Measurement temperature range (°C)	-100 to 200	0 to 400	0 to 600	0 to 600				
				Accuracy (%)	—	±0.3	±0.4	—				
				Temperature drift (°C)	—	±0.01	±0.011	—				

Table 3.2 A616TD and A60MXT Combination Performance List (Continue)

### 3. SPECIFICATIONS

Item		Specifications	Reference
Overall accuracy (%)		Values in table above $\pm 0.5^{\circ}\text{C}$ ( $\pm 0.5^{\circ}\text{C}$ is the cold-junction compensation accuracy)	Section 3.3
Cold-junction compensation temperature range ( $^{\circ}\text{C}$ )		-20 to 80 (Thermoresistor PT100 connected)	—
Max. conversion speed (ms/channel)		50	Section 3.3.2
Isolation	A616TD	Between input terminals and PC: Photocoupler isolation Between channels: Non-isolated (1M $\Omega$ resistor isolation)	—
	A60MXT	Between input terminals and PC: Photocoupler isolation Between channels: Mercury-plunger relay isolation Non-isolated when discontinuity detection is selected (20M $\Omega$ resistor isolation).	—
No. of temperature sensor input points (points per A60MXT)		15 (Up to 7 A60MXT modules can be connected to each A616TD.)	—
No. of I/O points occupied (points)	A616TD	32	—
	A60MXT	32 (Treated as empty slots. May be set to 0 by I/O assignment.)	—
Connection terminals		38-point terminal block	—
Applicable wire size (mm <sup>2</sup> )		0.75 to 2.0 (18 to 14 AWG) (applicable tightening torque: 7kg·cm (6.06lb·inch))	—
Applicable solderless terminal		V1.25-3 V1.25-YS3A V2-S3V2-YS3A	—
Internal current consumption at 5V DC (A)	A616TD	1.0	—
	A60MXT	0.8	—
Weight g (lb)	A616TD	850 (1.87)	—
	A60MXT	950 (2.09)	—
Dimensions mm (inch)	A616TD	37.5 (1.48) (W) $\times$ 250 (9.84) (H) $\times$ 131 (5.16) (D)	—
	A60MXT	75.5 (2.97) (W) $\times$ 250 (9.84) (H) $\times$ 131 (5.16) (D)	—

**Table 3.2 A616TD and A60MXT Combination Performance List**

\*1 The measurement ranges 2, 3, and 4 in the table are specified for a terminal-block (reference) temperature of 0 $^{\circ}\text{C}$ . If the actual terminal-block temperature, measured by the thermoresistor, is non-zero the measurement ranges are changed according to this temperature difference as follows:

Measurement range  $\left\{ \begin{array}{l} \text{Upper limit} = \text{measurement range upper limit from table.} \\ \text{Lower limit} = \text{terminal-block temperature.} \end{array} \right.$

#### Example

For a terminal-block temperature of 30 $^{\circ}\text{C}$  and a JIS K type thermocouple, measurement range 2 becomes 30 $^{\circ}\text{C}$  to 500 $^{\circ}\text{C}$ .

\*1 applies to the temperature measurement ranges. Refer to the standards listed in the Appendices for the actual thermocouple temperature ranges.

An out-of-range signal is output if the measurement ranges described above are exceeded. Accuracy cannot be guaranteed if the actual temperature range is exceeded.

### 3. SPECIFICATIONS

#### 3.2.2 Performance of the A616TD, A60MX and A60MXR combination

The performance specifications of the A616TD, A60MX and A60MXR are listed in the table below.

Item		Specifications	Reference																
Analog input	Voltage (V)	-10 to 0 to +10 DC	Section 3.4.1																
	Current (mA)	-20 to 0 to +20 DC																	
Digital output values		Binary digital values with a 16-bit sign (-48 to 4047 or -2048 to 2047: can be selected for each channel)	Section 3.4.1																
I/O characteristics	<table border="1"> <thead> <tr> <th colspan="2">Analog input range</th> <th rowspan="2">Digital output values</th> </tr> <tr> <th>Voltage (V)</th> <th>Current (mA)</th> </tr> </thead> <tbody> <tr> <td>0 to +10</td> <td>0 to +20</td> <td rowspan="6">0 to 4000 -2000 to 2000</td> </tr> <tr> <td>0 to +5</td> <td>0 to +20</td> </tr> <tr> <td>+1 to +5</td> <td>+4 to +20</td> </tr> <tr> <td>-10 to +10</td> <td>-20 to +20</td> </tr> <tr> <td>-5 to +5</td> <td>-20 to +20</td> </tr> </tbody> </table>		Analog input range		Digital output values	Voltage (V)	Current (mA)	0 to +10	0 to +20	0 to 4000 -2000 to 2000	0 to +5	0 to +20	+1 to +5	+4 to +20	-10 to +10	-20 to +20	-5 to +5	-20 to +20	Section 3.4.1
	Analog input range		Digital output values																
	Voltage (V)	Current (mA)																	
	0 to +10	0 to +20	0 to 4000 -2000 to 2000																
	0 to +5	0 to +20																	
	+1 to +5	+4 to +20																	
-10 to +10	-20 to +20																		
-5 to +5	-20 to +20																		
Overall accuracy (%)		±0.6 (Full-scale accuracy)		Section 3.4.3															
Max. conversion speed (ms/channel)		50	Section 3.4.2																
Max. absolute input	Voltage (V)	±15	—																
	Current (mA)	±30																	
Isolation	A616TD	Between input terminals and PC: Photocoupler isolation Between channels: Non-isolated (1MΩ resistor isolation)	—																
	A60MX	Between input terminals and PC: Photocoupler isolation Between channels: Non-isolated (1MΩ resistor isolation)																	
	A60MXR	Between input terminals and PC: Photocoupler isolation Between channels: Mercury-plunger relay isolation																	
No. of analog input points (points per module)		16	—																
No. of I/O points occupied (points)	A616TD	32	—																
	A60MX	16 (Treated as empty slots. May be set to 0 by I/O assignment.)																	
	A60MXR	16 (Treated as empty slots. May be set to 0 by I/O assignment.)																	
Connection terminals		38-point terminal block	—																
Applicable wire size (mm <sup>2</sup> )		0.75 to 2.0 (18 to 14 AWG) (applicable tightening torque: 7kg·cm (6.06lb·inch))	—																
Applicable solderless terminal		V1.25-3, V1.25-YS3A, V2-S3, V2-YS3A	—																
Internal current consumption at 5V DC (A)	A616TD	1	—																
	A60MX	0.65																	
	A60MXR	0.5																	
Weight g (lb)	A616TD	850 (1.87)	—																
	A60MX	550 (1.21)																	
	A60MXR	600 (1.32)																	
Dimensions mm (inch)	A616TD	37.5 (1.48) (W) × 250 (9.84) (H) × 131 (5.16) (D)	—																
	A60MX	37.5 (1.48) (W) × 250 (9.84) (H) × 131 (5.16) (D)																	
	A60MXR	37.5 (1.48) (W) × 250 (9.84) (H) × 131 (5.16) (D)																	

Table 3.3 A616TD, A60MX and A60MXR Combination Performance List

### 3. SPECIFICATIONS

#### 3.2.3 A616TD performance list

The A616TD analog-input characteristics are listed in Table 3.4. For items not listed in this table, refer to the temperature-digital conversion characteristics in Table 3.2.

Item	Specifications						
Analog input voltage (V)	0 to +10 DC (Input resistance: 1M $\Omega$ )						
Digital output	Binary digital values with a 16-bit sign (-48 to 4047 or -2048 to 2047: can be selected for each channel)						
Max. resolution of I/O characteristics	<table border="1"> <thead> <tr> <th>Analog input range (V)</th> <th>Max. resolution</th> <th>Digital output values</th> </tr> </thead> <tbody> <tr> <td>0 to +10</td> <td>2.5mV (1/4000)</td> <td>0 to 4000 -2000 to 2000</td> </tr> </tbody> </table>	Analog input range (V)	Max. resolution	Digital output values	0 to +10	2.5mV (1/4000)	0 to 4000 -2000 to 2000
	Analog input range (V)	Max. resolution	Digital output values				
0 to +10	2.5mV (1/4000)	0 to 4000 -2000 to 2000					
Overall accuracy (%)	A616TD stand-alone operation: $\pm 0.3$ (Full-scale accuracy)						
Max. conversion speed (ms/channel)	1 for stand-alone A616TD						
Max. absolute input voltage (V)	$\pm 15$						
Isolation	Between input terminals and PC: Photocoupler isolation Between channels: Non-isolated (1M $\Omega$ resistor isolation)						
No. of analog input points (points per module)	16						
No. of I/O points occupied (points)	32						

Table 3.4 A616TD Performance List (for analog inputs)



# 3. SPECIFICATIONS

## 3.3 Temperature - Digital Conversion

The temperatures detected by the temperature sensors (thermocouples) are input to the A616TD input channels as a thermoelectromotive force.

The A60MXT switches input channels once each sampling period and amplifies the voltage input to each channel from its respective thermocouple into the voltage range 0 to 10V, and sends this voltage to the A616TD.

The A616TD converts the analog input voltages to digital values. As the relationship between the thermoelectromotive force and the temperature for the temperature sensors (thermocouples) sensors is non-linear, the converted digital values are linearized before being stored in buffer memory.

### 3.3.1 Conversion characteristics

#### (1) Temperature detection characteristics

The A60MXT amplifies the non-linear outputs of the temperature sensors to the 0 to 10 V range and sends these signals to the A616TD where they are A/D converted, linearized and output as detected temperature values.

An example characteristic showing the relationship between the temperature sensor input values and the detected temperature values is shown in Fig. 3.1.

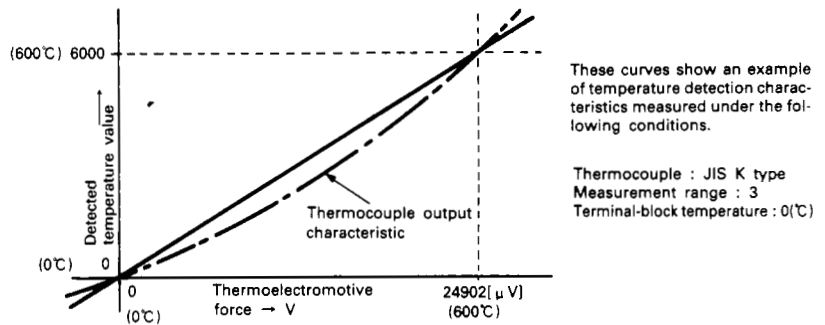

Fig. 3.1 Temperature Detection Characteristics

#### (2) Digital output characteristics

The temperatures representing digital outputs of 0 and 4000, respectively, are set in the buffer memory by the sequence program and are then used to output the appropriate digital values corresponding to each detected temperature in the temperature detection characteristic. An example characteristic showing the relationship between the detected temperature values and digital output values is shown in Fig. 3.2.

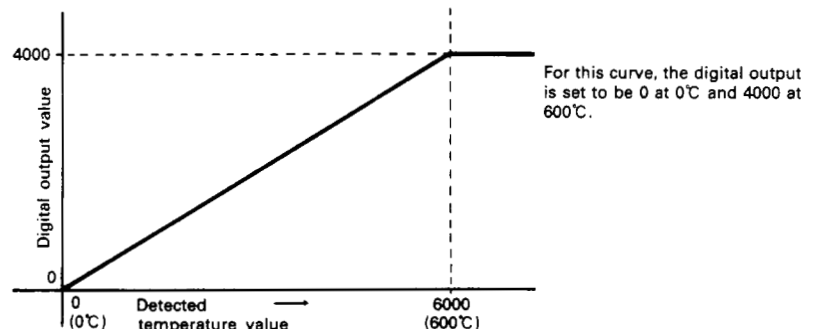

Fig. 3.2 Digital Output Characteristic

### 3. SPECIFICATIONS

#### 3.3.2 Conversion speed

The conversion speed of an A616TD and A60MXT combination is 50 milliseconds per channel.

The sequential conversion method used, whereby the processing for one channel is completed before processing is started for the next channel, gives a total sampling period of  $50\text{ms} \times$  the number of channels sampled. However, the sampling period can be decreased using the method described below.

Specify channel 0 of all A60MXT modules connected to the A616TD sequentially by (CONNECT NO.). After the input voltage has stabilized, A/D conversion is carried out for channel 0 of all A60MXT modules, in sequence starting from the module with CONNECT NO. 0. After A/D conversion is complete for channel 0 of all modules, the process is repeated for channel 1 of the modules in CONNECT NO. sequence, and so on, until A/D conversion has been completed for all channels.

This method brings large reductions in channel selection time and A/D conversion time. This method effectively results in parallel processing carried out simultaneously for the same channel number of each A60MXT module.

- (1) Using this method, the sampling period is determined by multiplying the number of conversion channels for the module with the maximum number of conversion channels enabled by 50 milliseconds.

That is,

$$\text{Sampling period} = \text{no. of conversion channels enabled} \times 50\text{ms}$$

Example

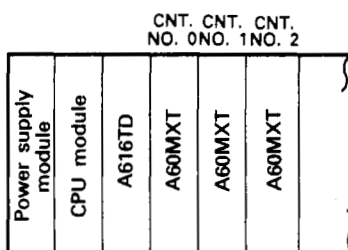

- 9 channels are enabled for A/D conversion for A60MXT CONNECT NO. 0.
- 8 channels are enabled for A/D conversion for A60MXT CONNECT NO. 1.
- 5 channels are enabled for A/D conversion for A60MXT CONNECT NO. 2.

The module with A/D conversion enabled for the highest number of channels is the A60MXT CONNECT NO. 0 module with nine channels enabled.

$$\text{Sampling period} = 50\text{ms} \times 9 = 450\text{ms}$$

- (2) The processing timing for the example in (1) above is shown below.

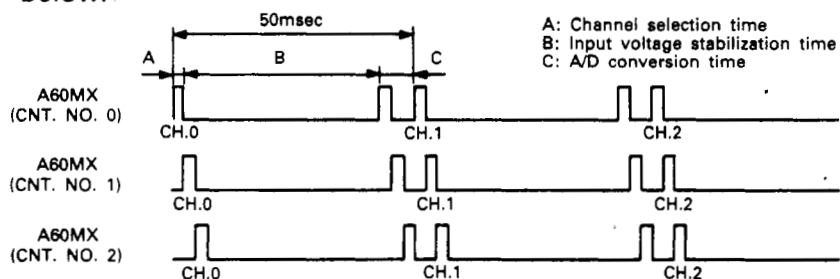

Fig. 3.3 Processing Timing

### 3. SPECIFICATIONS

#### 3.3.3 Life of the mercury-plunger relays

The life of the A60MXT mercury-plunger relays is 900 million cycles. The number of years of service life of the relays decreases as the sampling period decreases.

In order to increase the mercury-plunger relay service life, increase the sampling period by enabling conversion for all channels, including channels which are not being used.

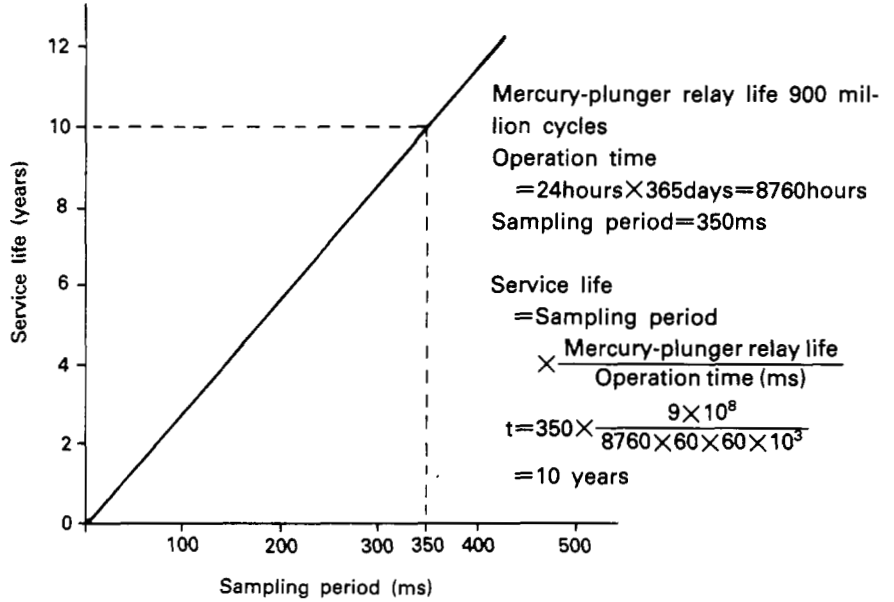

Fig. 3.4 Service Life of the Mercury-Plunger Relays

#### 3.3.4 Overall accuracy

The full-scale accuracy of A616TD and A60MXT combination lies within the values shown in Table 3.2. However, the accuracy ( $\pm 0.5^\circ\text{C}$ ) of the thermoresistor Pt100, has to be added over the entire measurement temperature range.

##### Example

When measurement range 2 is selected while using a JIS K type thermocouple, the detected temperatures corresponding to temperatures of  $0^\circ\text{C}$ ,  $250^\circ\text{C}$  and  $500^\circ\text{C}$ , respectively, lie within the following ranges.

- Accuracy of the A616TD and A60MXT combination  
 :  $500 \times 0.003 = \pm 1.5^\circ\text{C}$  (from Table 3.2)
- Overall accuracy upper limit value incorporating thermoresistor accuracy  
 :  $1.5 + 0.5 = 2^\circ\text{C}$
- Overall accuracy lower limit value incorporating thermoresistor accuracy  
 :  $-1.5 - 0.5 = -2^\circ\text{C}$

The detected temperature ranges at each sampling temperature become as follows:

- Detected temperature ranges  $\left\{ \begin{array}{l} 0^\circ\text{C} : -2^\circ\text{C} \text{ to } 2^\circ\text{C} \\ 250^\circ\text{C} : 248^\circ\text{C} \text{ to } 250^\circ\text{C} \\ 500^\circ\text{C} : 498^\circ\text{C} \text{ to } 502^\circ\text{C} \end{array} \right.$

### 3. SPECIFICATIONS

#### 3.3.5 Discontinuity detection function

This function is provided to detect electrical discontinuities in thermocouples and compensating leads connected to the A60MXT.

If a break occurs in a thermocouple lead or a compensating lead, as shown in Fig. 3.5, the A60MXT internal discontinuity detection circuit outputs a voltage to the A616TD which is equivalent to an out-of-range detected temperature value. The A616TD detects the discontinuity from the out-of-range voltage and stores the value "1" for the appropriate channel in the discontinuity detection area of the buffer memory and turns on the discontinuity error signal. The discontinuity detection function can be enabled or disabled for each channel by setting the discontinuity detection switches and buffer memory discontinuity detection channels in buffer memory.

(Refer to Sections 4.5 and 5.4.3 for details.)

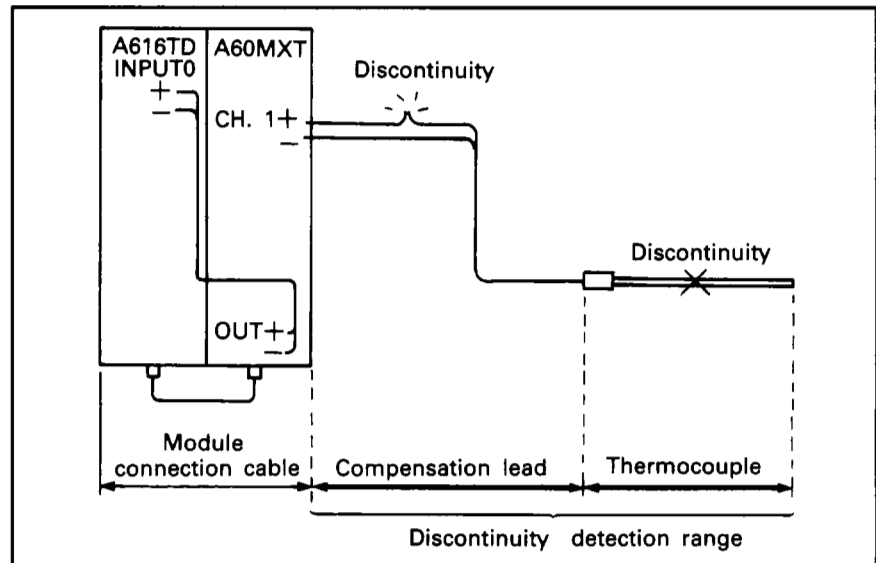

Fig. 3.5 Discontinuity Detection Range

#### 3.3.6 Error compensation function

This function is provided to compensate for errors between actual temperatures and measured temperatures arising from differences in thermocouple accuracy, compensation lead lengths and location conditions of the thermocouples. Considerable errors can arise between actual temperatures and measured temperatures for each thermocouple. Therefore, the error compensation function should always be used to eliminate for these errors. Error compensation is carried out by measuring a standard temperatures, for example 0°C ice-water a 100°C boiling water at atmospheric pressure. The differences between the measured values and the actual temperatures are then input as compensation values into the buffer memory. (Refer to Section 5.5 for details.)

## 3. SPECIFICATIONS

### 3.4 Analog/Digital Conversion

Channels are switched once each sampling period to sample the analog signals input from external sensors to the A60MXT, A60MX and A60MXR. The analog signals are converted to digital signals and stored in the buffer memory.

#### 3.4.1 Conversion characteristics

(1) A616TD I/O characteristics

The A616TD analog input range is fixed from 0 to +10V. The I/O characteristics are shown in Fig. 3.6.

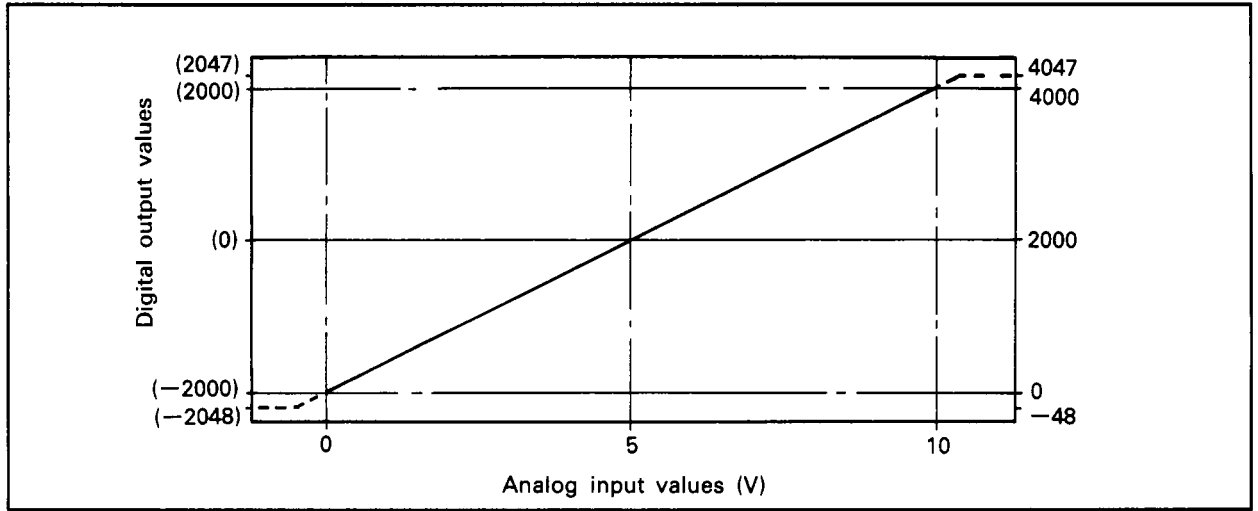

Fig. 3.6 A616TD I/O Characteristics

- 1) The digital output values can be selected from two output data formats: in the range  $-48$  to  $4047$  or  $-2048$  to  $2047$ . The output data format can be specified for each channel independently. (Refer to Section 6.2.1 (1) for details.)
- 2) The maximum resolution and overall accuracy values lie within the ranges shown in Table 3.4, when the input voltage is in the 0 to 10V range. However, the maximum resolution and overall accuracy values may not lie within these ranges if the input voltage exceeds the 0 to 10V range. Use of the sections of the A616TD I/O characteristic curve shown as a broken line in Fig. 3.6 should be avoided as the accuracy value may not comply with the table in these regions.
- 3) If an analog input is received which would cause the output value to exceed  $4047$  or  $-48$  when the output data format with the range  $-48$  to  $4047$  is specified, the output is held at  $4047$  or  $-48$ , respectively. Similarly, if an analog input is received which would cause the output value to exceed  $2047$  or  $-2048$  when the output data format with the range  $-2048$  to  $2047$  is specified, the output is held at  $2047$  or  $-2048$ , respectively.
- 4) Do not input a voltage exceeding  $\pm 15V$  as this may damage the module.

### 3. SPECIFICATIONS

#### (2) A60MX and A60MXR I/O Characteristics

Voltage input or current input can be selected for each A60MX and A60MXR channel by means of the analog input select switch. The offset/gain setting is carried out for blocks of 16 channels.

The I/O characteristics are preset by means of the analog input select switch and the positions of the offset/gain setting pins. The characteristics when the analog input select switch is set to voltage input are described in (1) below, and the characteristics when the analog input select switch is set to current input are described in (2).

#### (a) Voltage input characteristics

The characteristics when the analog input select switch is set to the voltage input position are shown below.

A60MX and A60MXR Output Voltage (V)	Analog Input Range (V)	Offset/Gain Setting Pin Position		I/O Characteristic
		S17	S18	
0 to 10	0 to +10	1 ☆	1 ☆	① in Fig. 3.7
	0 to +5	2	1	② in Fig. 3.7
	+1 to +5	3	2	③ in Fig. 3.7
	-10 to +10	4	3	④ in Fig. 3.7
	-5 to +5	1	3	⑤ in Fig. 3.7

☆Setting before shipment

Table 3.5 Analog Input Range and Offset/Gain Setting Pin Position

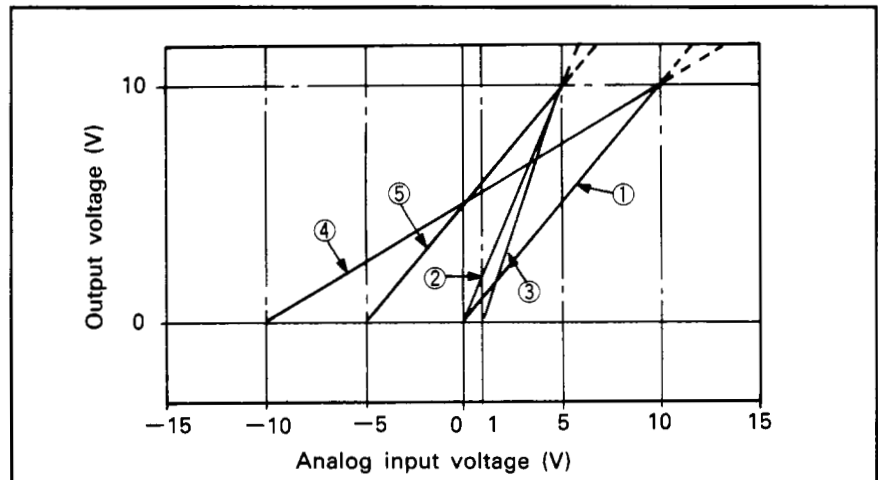

Fig. 3.7 A60MX and A60MXR I/O Characteristics (for voltage input)

### 3. SPECIFICATIONS

(b) Current input characteristics

The characteristics when the analog input select switch is set to the current input position are shown below.

A60MX and A60MXR Output Voltage (V)	Analog Input Range (mA)	Offset/Gain Setting Pin Position		I/O Characteristic
		S17	S18	
0 to 10	0 to +20	1 ☆	1 ☆	① in Fig. 3.8
	0 to +20	2	1	② in Fig. 3.8
	+4 to +20	3	2	③ in Fig. 3.8
	-20 to +20	4	3	④ in Fig. 3.8
	-20 to +20	1	3	⑤ in Fig. 3.8

☆Setting before shipment

Table 3.6 Analog Input Range and Offset/Gain Setting Pin Position

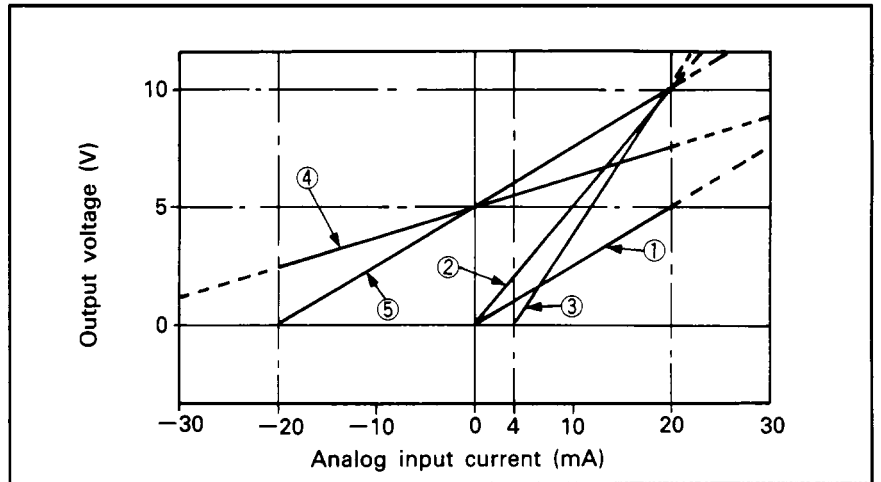

Fig. 3.8 A60MX and A60MXR I/O Characteristics (for current input)

#### 3.4.2 Conversion speed

The conversion speed when A60MX and/or A60MXR modules are connected to the A616TD is identical to when A60MXT modules are connected.

Refer to Section 3.3.2 for details of the conversion speed and processing timing.

### 3. SPECIFICATIONS

#### 3.4.3 Overall Accuracy

The graphs given below indicate the overall accuracies (with respect to the maximum value) of the A616TD, A60MX and A60MXR used individually and in combination.

If the I/O characteristic is changed by the Offset/Gain setting pin, the overall accuracy remains unchanged and is kept within the range of the performance specifications.

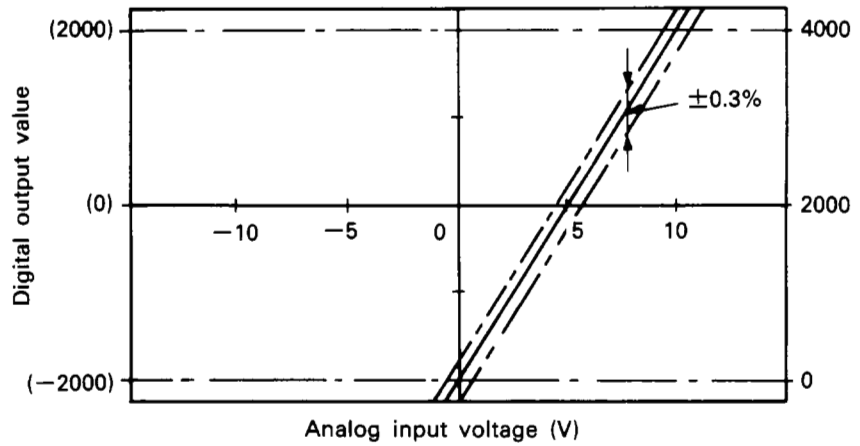

Fig. 3.9 A616TD Overall Accuracy

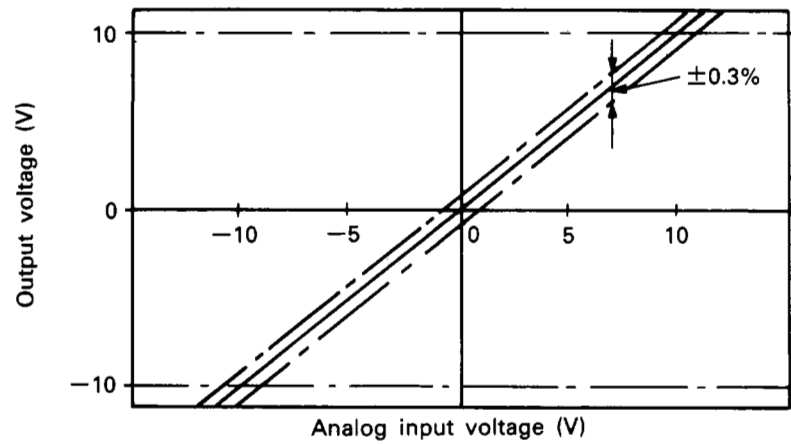

Fig. 3.10 A60MX/A60MXR Overall Accuracy

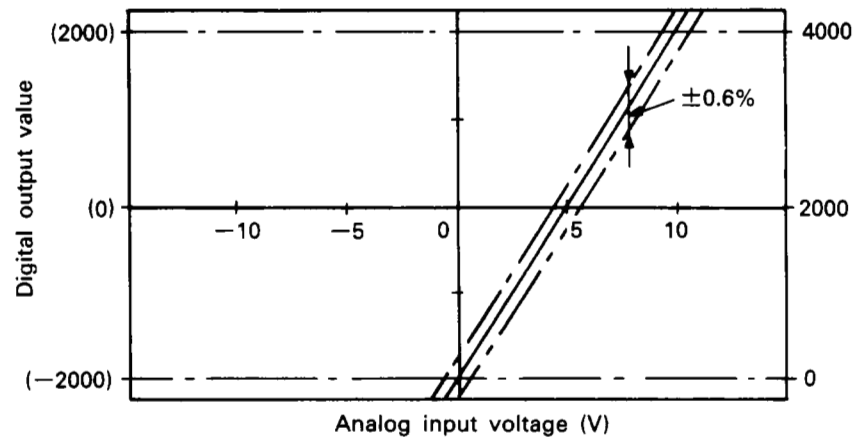

Fig. 3.11 Overall Accuracy when A616TD is Used with A60MX/A60MXR



# 3. SPECIFICATIONS

## 3.5 Function Block Diagrams

### 3.5.1 Function block diagram of A616TD and A60MXT combination

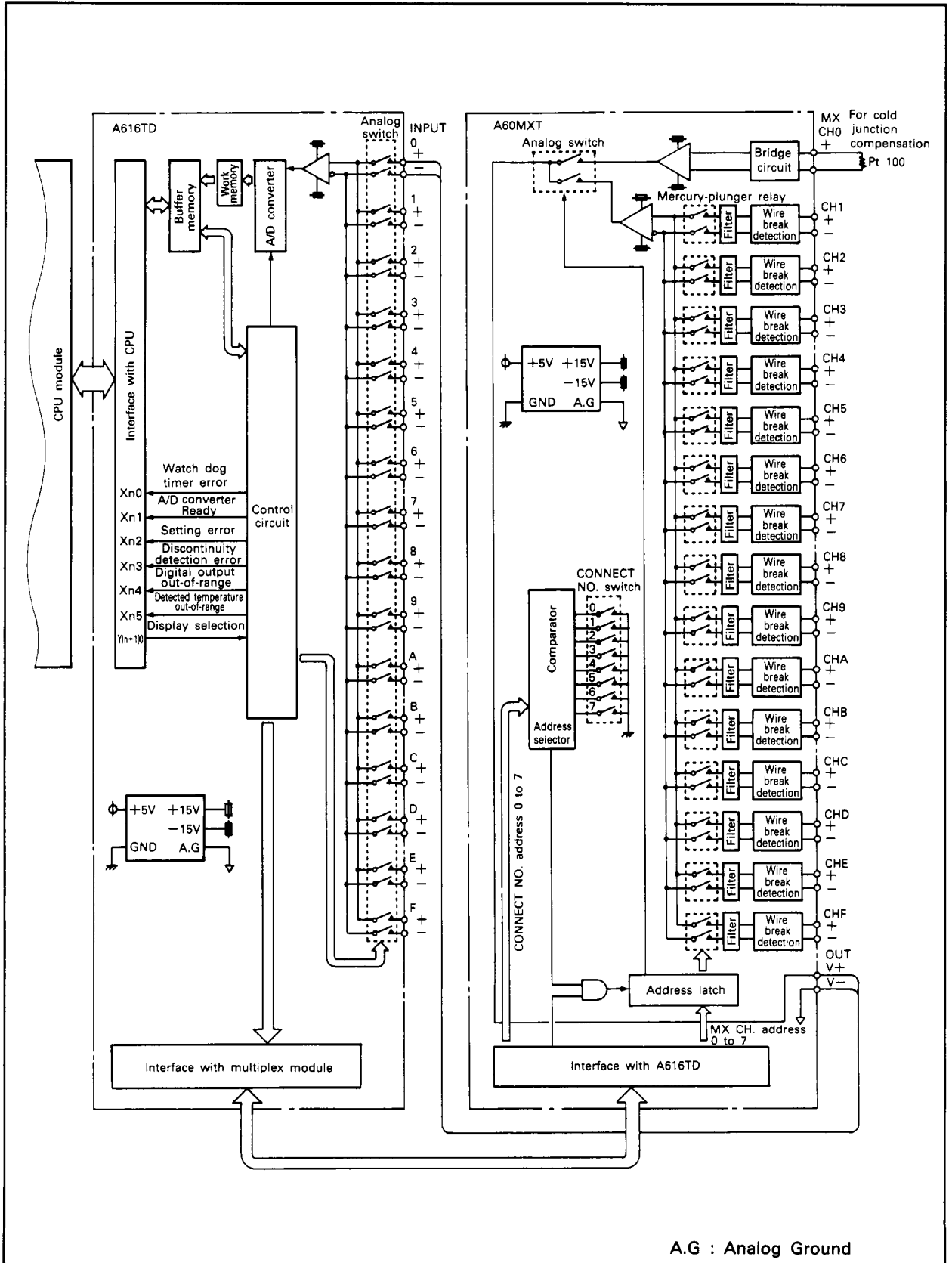

### 3. SPECIFICATIONS

#### 3.5.2 A60MX function block diagram

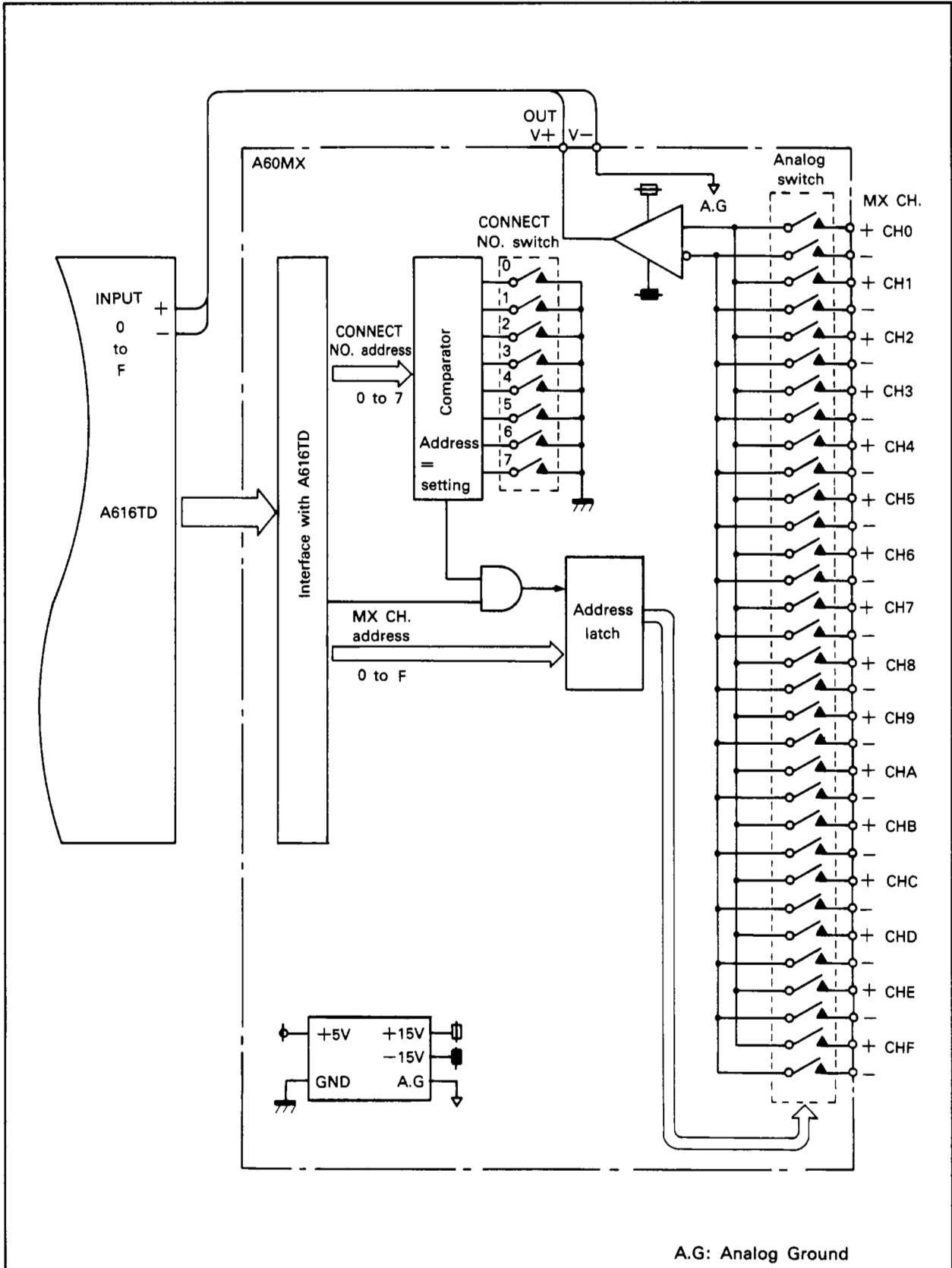

### 3. SPECIFICATIONS

#### 3.5.3 A60MXR function block diagram

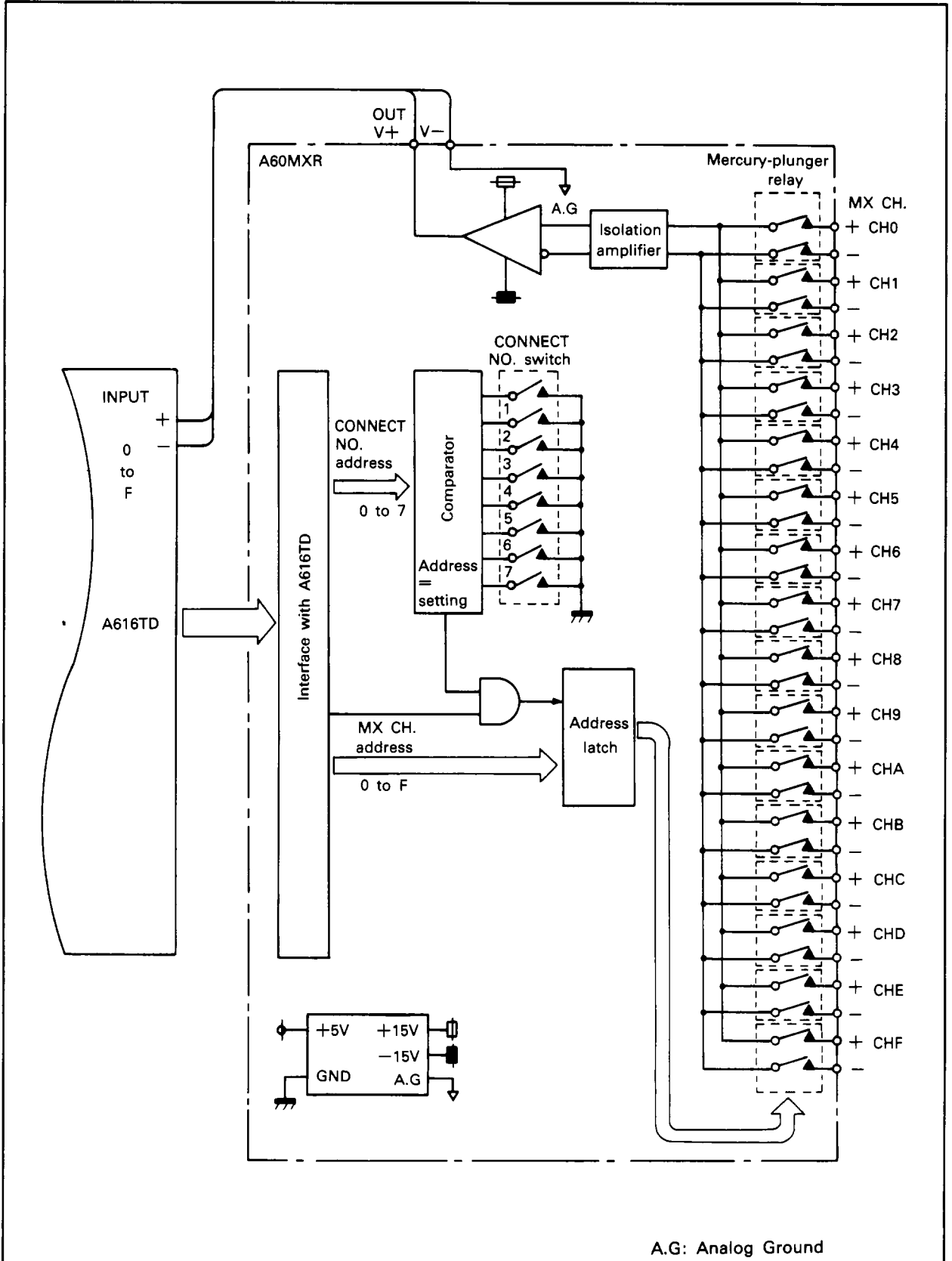

## 4. PRE-OPERATION SETTING AND PROCEDURES

### 4. PRE-OPERATION SETTINGS AND PROCEDURES

#### 4.1 Pre-Operation Settings and Procedures

Make the following settings before carrying out temperature sensor input into an A616TD and A60MXT combination. Refer to Chapter 6 for the setting procedure for analog inputs.

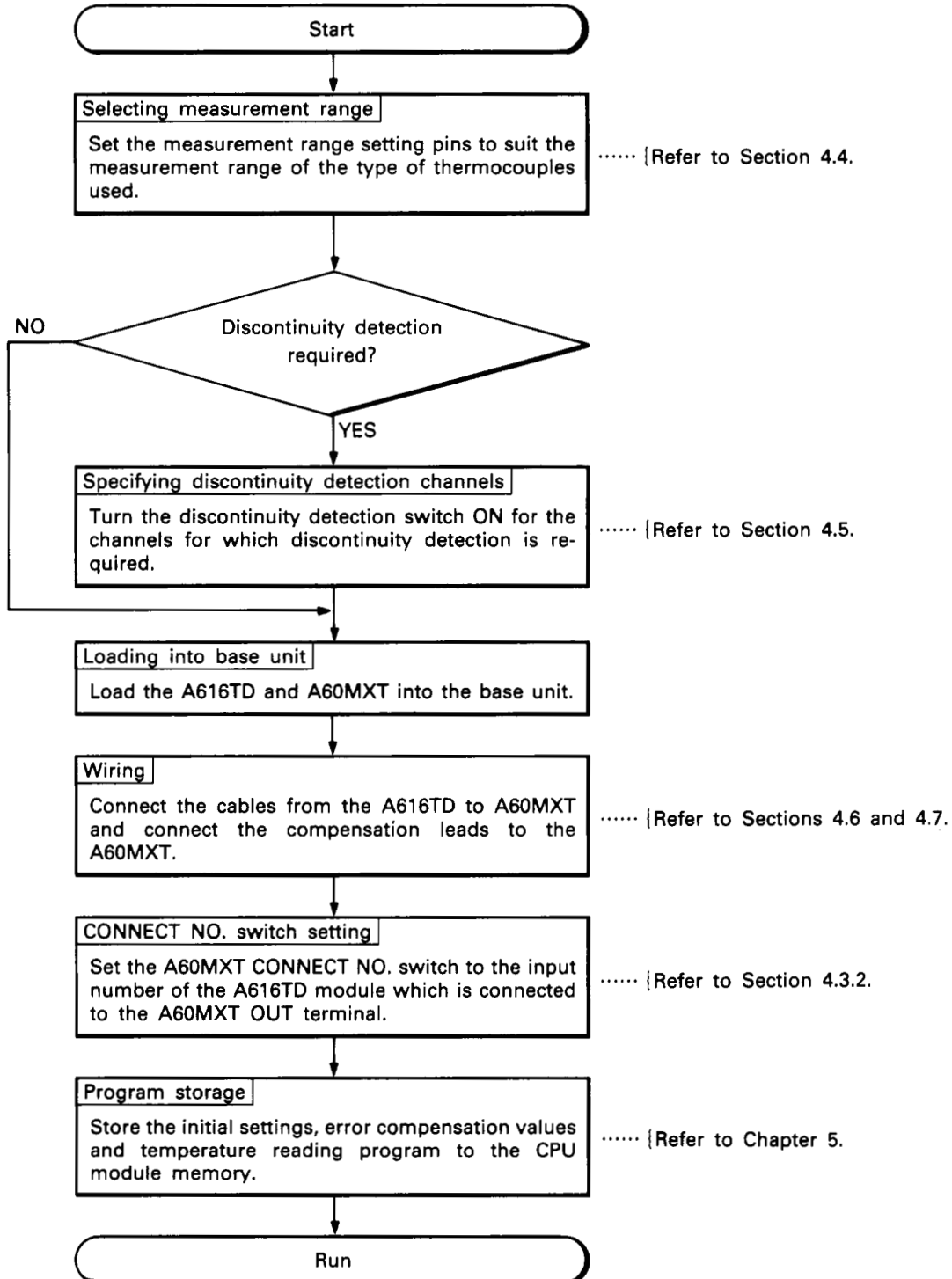

## 4. PRE-OPERATION SETTINGS AND PROCEDURES

### 4.2 Handling Instructions

Consider the following important points when handling an A616TD or A60MXT module.

- (1) The A616TD and A60MXT cases and terminal blocks are made of plastic. Do not drop them or subject them to impact loads.
- (2) Do not remove printed circuit boards from the housing. There are no user-serviceable parts on the boards.
- (3) Ensure that no conductive debris can enter the module. If it does, make sure that it is removed. Guard particularly against wire offcuts.
- (4) Tighten terminal screws as specified below:

Screw	Tightening Torque Range kg-cm (lb-inch)
I/O terminal block terminal screws (M3)	5 (4.33) to 8 (6.93)
I/O terminal block installation screws (M4)	8 (6.93) to 14 (12.13)

- (5) To load the module onto the base, press the module against the base so that the hook is securely locked. To unload the module, push the catch on top of the module, and after the hook is disengaged from the base, pull the module toward you.
- (6) Refer to the diagram below when removing the left side plate of the unit.

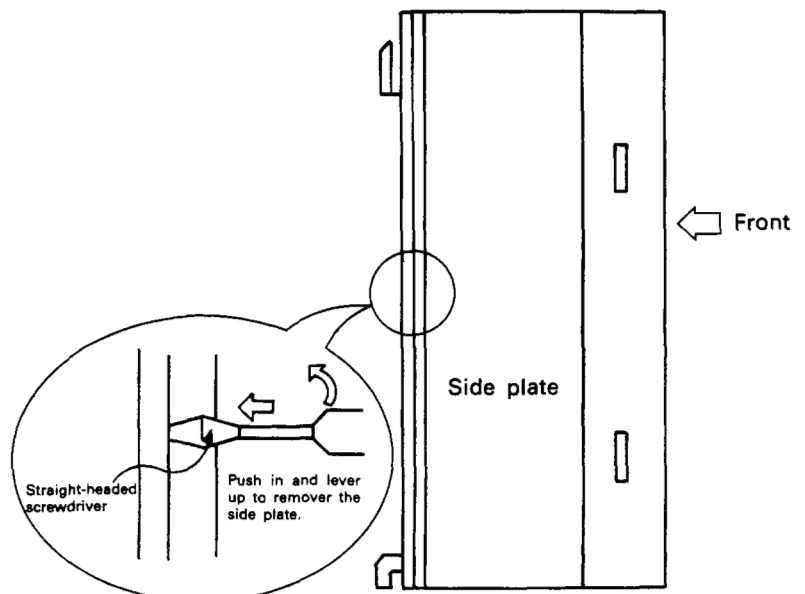





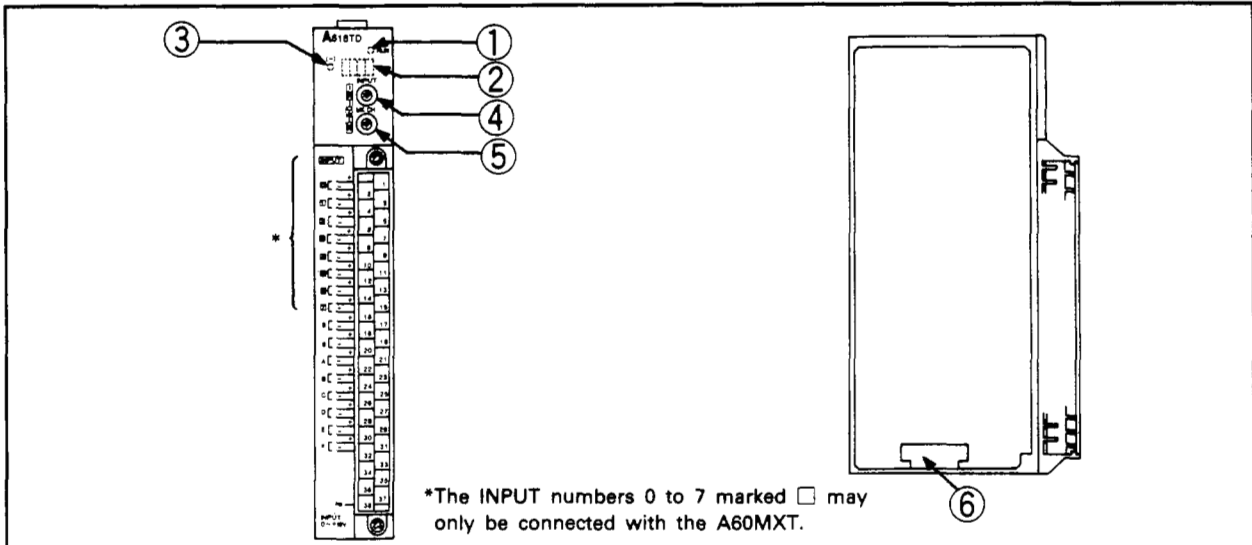

# 4. PRE-OPERATION SETTINGS AND PROCEDURES

## 4.3 Nomenclature



### 4.3.1 A616TD

Description and settings of A616TD parts.

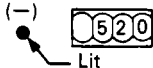

No.	Name and Appearance	Description
①	<b>RUN LED</b>  	Indicates the operating status of the A616TD. On: Indicates that the A616TD is operating without fault. Flicker: Indicates that disable area write error, INPUT switch setting error, etc. has occurred. See Section 7.1. Off: Indicates 5V power-off, watch dog timer error or A60MXT/A60MX/A60MXR module fault.
②	<b>LED display</b>  	(1) Digital value indication <ul style="list-style-type: none"> <li>Indicates the digital value of the channel specified by the INPUT switch (④) and MX CH. switch (⑤) when Y10 is OFF.</li> <li>Indicates a digital value as a 4-digit decimal (in the range -48 to 4095 or -2048 to +2047).</li> <li>The minus indicator LED (③) is lit to indicate a negative digital value.</li> <li>Updates a digital value in 500ms increments.</li> </ul> (2) Detected temperature value indication <ul style="list-style-type: none"> <li>Indicates the detected temperature value of the channel specified by the INPUT switch (④) and MX CH. switch (⑤) when Y10 is ON.</li> <li>However, a digital value is indicated if the specified channel is not connected to an A60MXT module.</li> <li>Detected temperature values are displayed a 4-digit decimals. If the indicated temperature does not exceed 1000°C, e.g., 725.4°C.</li> </ul> <div style="text-align: center;">  <p>Temperature is indicated to one decimal place.</p> </div> <p>If the indicated temperature exceeds 1000°C, e.g., 1208.5°C.</p> <div style="text-align: center;">  <p>No decimal places are indicated.</p> </div> <ul style="list-style-type: none"> <li>The minus-sign LED (③) lights to indicate a negative value.</li> </ul> (3) Error number indication <ul style="list-style-type: none"> <li>If an error has occurred, the corresponding error code is displayed as shown below:</li> </ul> <div style="text-align: center;">  <p>Error code is indicated by the two least significant digits.</p> </div>

## 4. PRE-OPERATION SETTING AND PROCEDURES



No.	Name and Appearance	Description
③	Minus indicator LED 	Lit to indicate that the digital value is negative. Example: Digital value -520. 
④	INPUT switch 	Used to specify the channel of which the digital value or detected temperature value is to be displayed on the LED display. <ul style="list-style-type: none"> <li>• Use the MX CH. switch (⑤) to specify the channel of the module selected.</li> <li>• Setting range: 0 to 7</li> </ul>
⑤	MX CH. switch 	Used to specify the channel of which the digital value or detected temperature value is to be displayed on the LED display. <ul style="list-style-type: none"> <li>• The LED display (②) indicates the digital value or detected temperature value of the MX CH. switch-specified channel of the module selected by the INPUT switch.</li> <li>• Setting range: 0 to F</li> </ul>
⑥	Extension cable connector	For connecting the extension cable.

## 4. PRE-OPERATION SETTINGS AND PROCEDURES

### 4.3.2 A60MXT

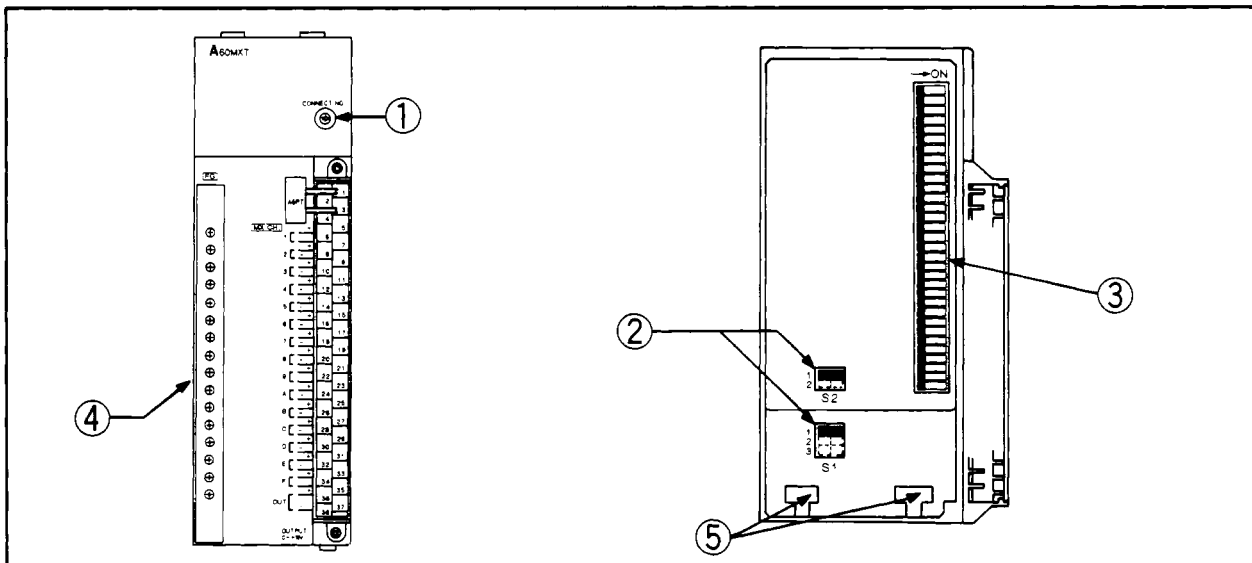
Description and settings of A60MXT parts.

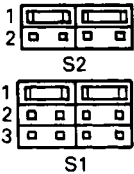

No.	Name and Appearance	Description
①	<p>CONNECT NO. switch</p>  <p>CONNECT NO.</p>	<p>A60MXT CONNECT NO. setting switch.</p> <ul style="list-style-type: none"> <li>Used to specify to which input of the A616TD the A60MXT output is connected.</li> <li>Setting range: 0 to 7</li> </ul>
②	<p>Used to set the temperature measurement range.</p> 	<p>Set the measurement range to suit to the temperature range to be measured and the type of thermocouple used.</p> <ul style="list-style-type: none"> <li>Four setting ranges are available. Refer to Section 4.4 for details.</li> <li>The temperature range is set to "4" when the module is shipped from the factory.</li> </ul>
③	<p>Discontinuity detection switch</p> 	<p>Used to enable the discontinuity detection function which detects electrical discontinuity in thermocouples or compensation leads.</p> <ul style="list-style-type: none"> <li>Enable or disable the discontinuity detection function for each channel.</li> <li>Refer to Section 4.5 for details of the discontinuity detection function.</li> <li>The discontinuity detection function is disabled for all channels when the module is shipped from the factory.</li> </ul>
④	<p>FG terminal block</p>	<p>Connect the shields of the compensation leads to this terminal block.</p>
⑤	<p>Extension cable connector</p>	<p>For connecting the extension cable of the adjacent module when increasing a channel by loading the other A60MXT/A60MX/A60MXR next to the A60MXT.</p> <p>The extension cable may be connected to either of the two connectors.</p>



# 4. PRE-OPERATION SETTINGS AND PROCEDURES

## 4.4 Setting the A60MXT Measurement Range

Follow the procedure below to set the measurement range to suit to the temperature range to be measured and the type of thermocouple used.

The measurement range is specified for a blocks of 15 channels; it cannot be specified for individual channels.

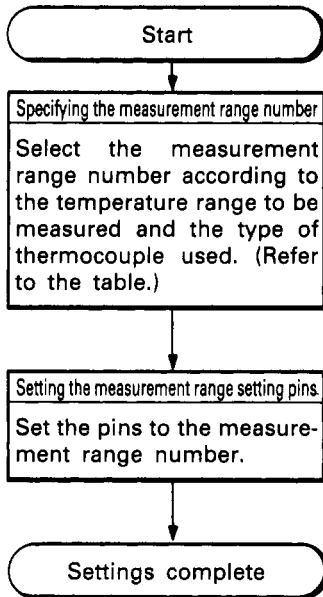

				Measurement Range No.	1	2	3	4
JIS Standard	ANSI Standard	DIN Standard	BS Standard	Permitted Input Voltage Range (mV)	-12.5 to 12.5	0 to 25	0 to 50	0 to 100
B	B	—	PtRh30 -PtRh6	Temperature measurement range (°C)	100 to 1500	100 to 1800	100 to 1800	100 to 1800
				Accuracy (%)	—	±0.5	—	—
				Temperature drift (°C)	—	±0.013	—	—
R	R	—	PtRh13 -Pt	Temperature measurement range (°C)	0 to 1000	0 to 1700	0 to 1700	0 to 1700
				Accuracy (%)	—	±0.4	—	—
				Temperature drift (°C)	—	±0.011	—	—
S	S	PtRh -Pt	PtRh10 -Pt	Temperature measurement range (°C)	0 to 1200	0 to 1700	0 to 1700	0 to 1700
				Accuracy (%)	—	±0.4	—	—
				Temperature drift (°C)	—	±0.011	—	—
K	K	NiCr -Ni	NiCr -NiAl	Temperature measurement range (°C)	-200 to 250	0 to 500	0 to 1000	0 to 1300
				Accuracy (%)	±0.4	±0.3	±0.3	±0.5
				Temperature drift (°C)	±0.011	±0.01	±0.01	±0.013
E	E	—	NiCr -CuNi	Temperature measurement range (°C)	-200 to 150	0 to 300	0 to 600	0 to 1000
				Accuracy (%)	±0.4	±0.3	±0.3	±0.4
				Temperature drift (°C)	±0.011	±0.01	±0.01	±0.011
J	J	—	Fe- CuNi	Temperature measurement range (°C)	-200 to 200	0 to 400	0 to 800	0 to 1200
				Accuracy (%)	±0.4	±0.3	±0.3	±0.4
				Temperature drift (°C)	±0.011	±0.01	±0.01	±0.011
T	T	—	Cu- CuNi	Temperature measurement range (°C)	-200 to 200	0 to 400	0 to 400	0 to 400
				Accuracy (%)	±0.5	±0.3	—	—
				Temperature drift (°C)	±0.013	±0.01	—	—
—	—	Fe- CuNi	—	Temperature measurement range (°C)	-100 to 200	0 to 400	0 to 800	0 to 900
				Accuracy (%)	—	±0.3	±0.3	±0.5
				Temperature drift (°C)	—	±0.01	±0.01	±0.013
—	—	Cu- CuNi	—	Temperature measurement range (°C)	-100 to 200	0 to 400	0 to 600	0 to 600
				Accuracy (%)	—	±0.3	±0.4	—
				Temperature drift (°C)	—	±0.01	±0.11	—

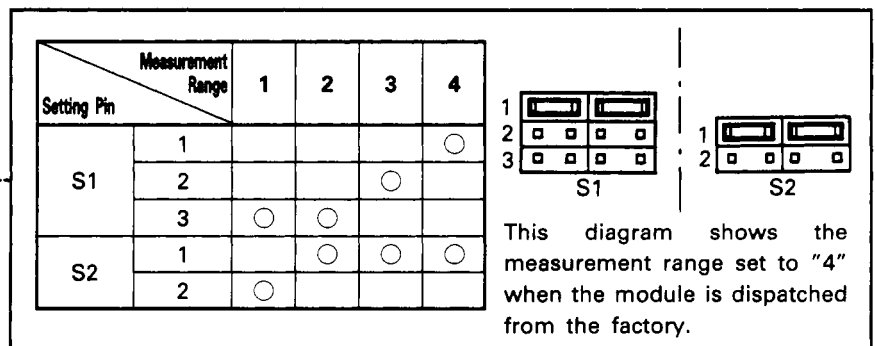

## 4. PRE-OPERATION SETTINGS AND PROCEDURES

---

<b>POINT</b>
--------------

- |  |
|--|
| <p>(1) A setting error occurs and the following occur if the setting pins are set to any combination other than 1 to 4.</p> <ul style="list-style-type: none"><li>(a) Modules set outside the measurement range 1 to 4 : no processions<br/>Modules set within the measurement range 1 to 4 : processing continues</li><li>(b) Error number "04" is displayed on the A616TD LED display.</li><li>(c) Error code "04" is stored in the buffer memory address 1.</li><li>(d) The A616TD RUN LED flashes. Refer to Section 5.12 for the method of resetting this error.</li></ul> |
|--|

# 4. PRE-OPERATION SETTINGS AND PROCEDURES

## 4.5 Setting the Discontinuity Detection Channels

The channels for which thermocouples and compensation leads with electrical discontinuities are detected are specified with the discontinuity detection switches and by writing the channel numbers to buffer memory.

The procedure for setting the switches is described below.

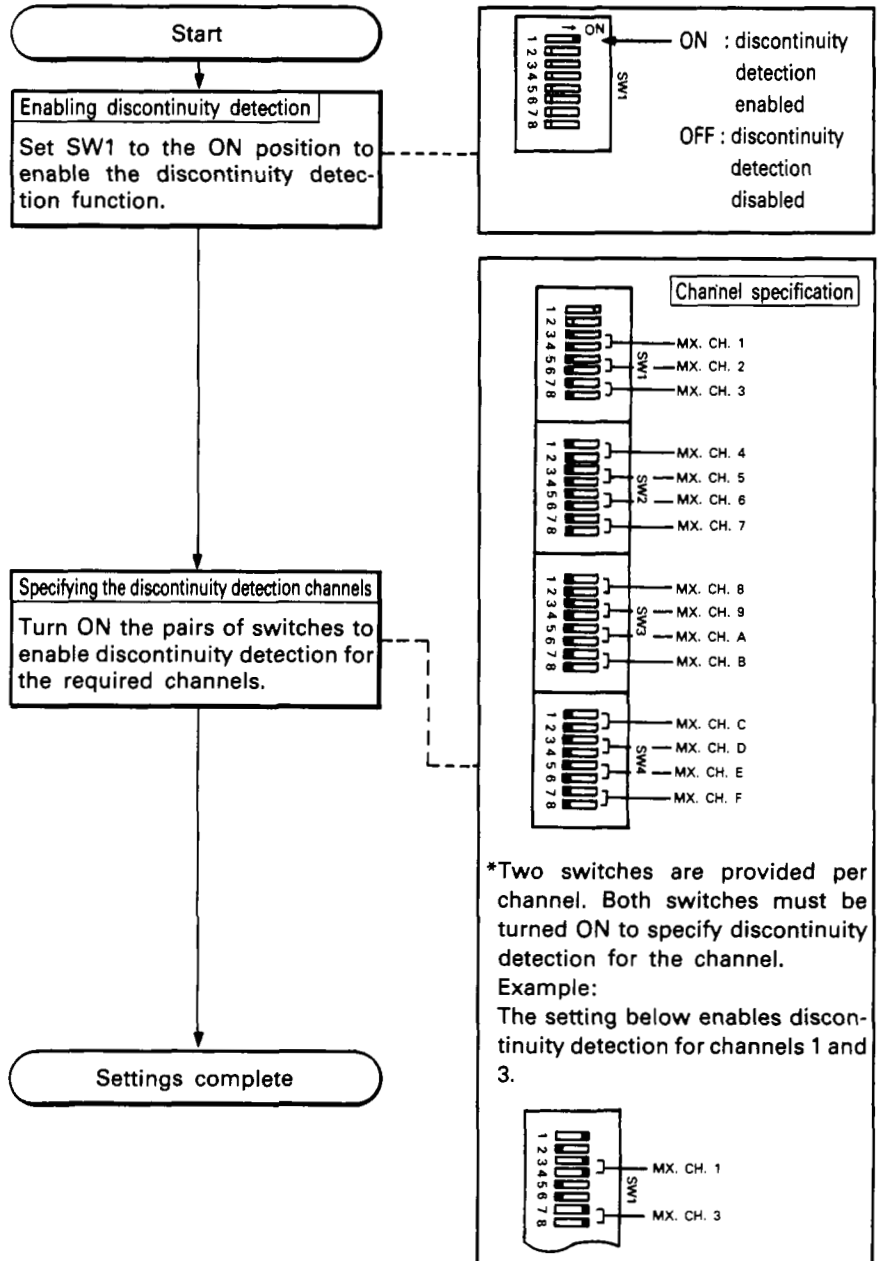

### REMARKS

The switch 2 of the discontinuity detection enable switch, SW1, is unconnected and may be set to the ON or OFF position.

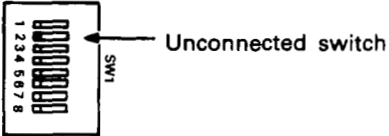

## **4. PRE-OPERATION SETTINGS AND PROCEDURES**

---

### **4.6 Wiring Instructions**

It is an essential condition for correct and reliable operation of systems incorporating the A616TD and A60MXT modules that wiring must be resistant to noise effects.

Note the following precautions when connecting A616TD and A60MXT wiring.

- (1) Use separate cables for AC control circuit wiring and A616TD or A60MXT external signal input wiring to eliminate induced surges from the control circuit wiring.
- (2) External wiring must be at least 10cm (4inches) away from main circuit and/or AC control circuit wiring.  
To reduce noise and surge induction effects, sufficiently separate external wiring from high-voltage wiring and any circuit that includes harmonics, such as inverter load main circuits.
- (3) Ground the shielding of all wires to a common ground point.

## 4. PRE-OPERATION SETTINGS AND PROCEDURES

### 4.7 Wiring Examples

Wiring example for thermocouple input to A616TD and A60MXT.

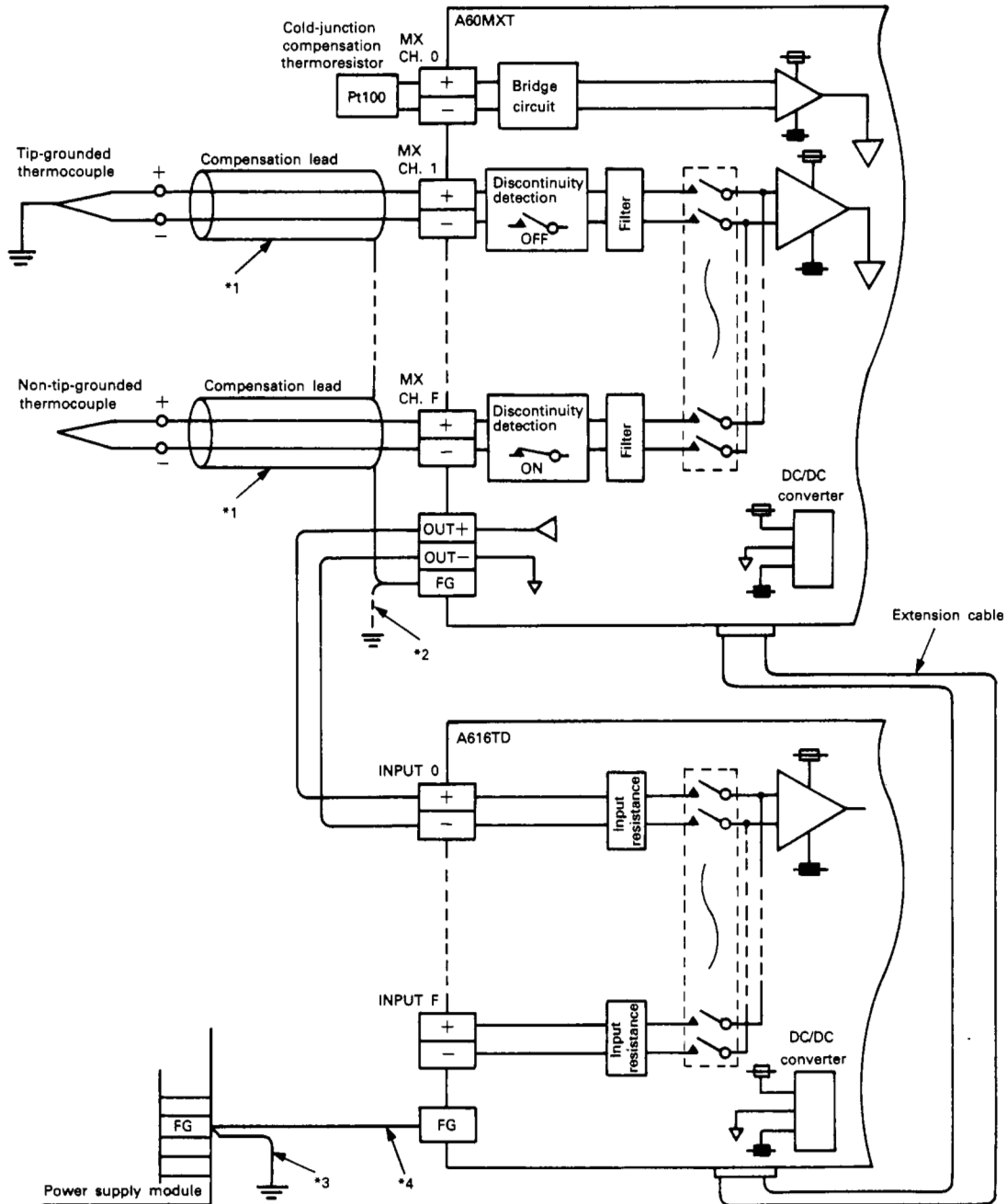

- \*1: Use only compensation leads.
- \*2: Always ground the compensation lead shields to the FG terminals.
- \*3: The FG terminals of the power supply module must be grounded.
- \*4: Always connect the A616TD FG terminal to the power supply module FG terminal.

## 4. PRE-OPERATION SETTINGS AND PROCEDURES

---

### POINT

Discontinuity detection may not be specified for channels to which tip-grounded thermocouples are connected, because the potential difference arising due to the difference in ground resistance between the thermocouple and discontinuity detection circuit ground points causes a current which gives rise to flow errors.

# 5. PROGRAMMING

## 5. PROGRAMMING

### 5.1 Programmable Controller CPU I/O List

The A616TD uses 32 input and 32 output points for communication of data with the PC CPU. I/O signal assignment and functions are as follows.

Device X indicates an input signal from the A616TD to the PC CPU and device Y an output signal from the PC CPU to the A616TD. I/O numbers used in this manual assume that the A616TD is located at slot 0 of the main base.

Signal Direction : A616TD to PC CPU		Signal Direction : PC CPU to A616TD	
Device no.	Signal name	Device no.	Signal name
X0	Watch-dog time error (detected by A616TD)	Y0 to YC	Restricted for system use. Not available for user.
X1	A/D conversion ready		
X2	Error flag		
X3	Discontinuity error detected		
X4	Digital output value out-of-range		
X5	Temperature output value out-of-range	YD to YF	<b>RFRP</b> , <b>RTOP</b> instruction interlock signal when A616TD is used in a remote I/O station.
X6 to X1C	Not used	Y10	Detected temperature value LED display request signal.
X1D to X1F	<b>RFRP</b> , <b>RTOP</b> instruction interlock signal when A616TD is used in a remote I/O station.	Y11 to Y1F	Restricted for system use. Not available for user.

Table 5.1 Input and Output Signals

#### IMPORTANT

Device numbers Y0 to YC and Y11 to Y1F shown in Table 5.1 are reserved for system use and must not be turned on or off by a sequence program. Performance of the A616TD cannot be guaranteed if these device numbers are manipulated by a program.

Y0 to Y1F, corresponding to X0 to X1F, cannot be used as external relays.

## 5. PROGRAMMING

### (1) Watch dog timer (X0)

On indicates that the A616TD has self-detected a watch dog timer error and stops the A/D conversion of the A616TD. The watch dog timer error indicates an A616TD hardware fault.

### (2) A/D conversion ready (X1)

Switched on when the set data is made valid by writing "1" to the set data setting request area of the buffer memory with the sequence program.

Switched off by writing "1" again to the set data setting request area during A/C conversion and switched on again when A/D conversion is ready after data check.

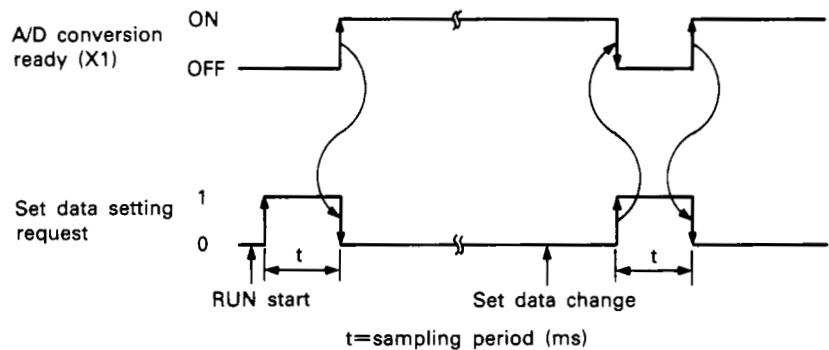

### (3) Error flag (X2)

On indicates that an error other than the watch dog timer error has occurred in the A616TD and the corresponding error code has been stored to the error code area.

Switched off by writing "0" to the error code area by the sequence program.

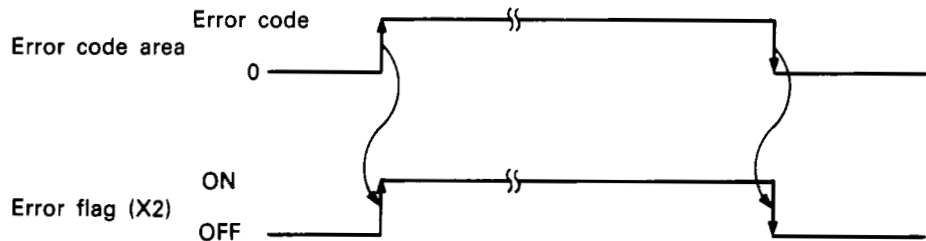

### (4) Discontinuity error detected (X3)

This signal is turned on if a single "1" is set in the buffer memory discontinuity detection area. The signal is turned off by writing "0" to the discontinuity detection area with the sequence program.

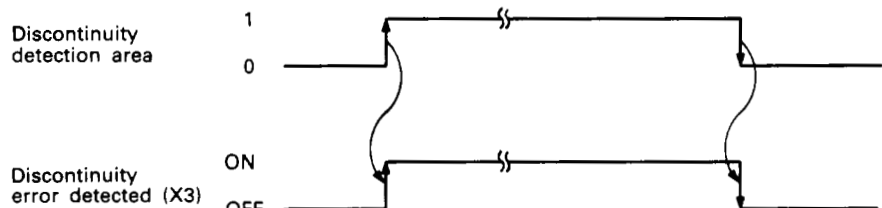



## 5. PROGRAMMING

### (5) Digital output value out-of-range (X4)

This signal is turned on if a single "1" is set in the buffer memory digital output value out-of-range detection area. The signal is turned off by writing "0" to the digital output value out-of-range detection area with the sequence program.

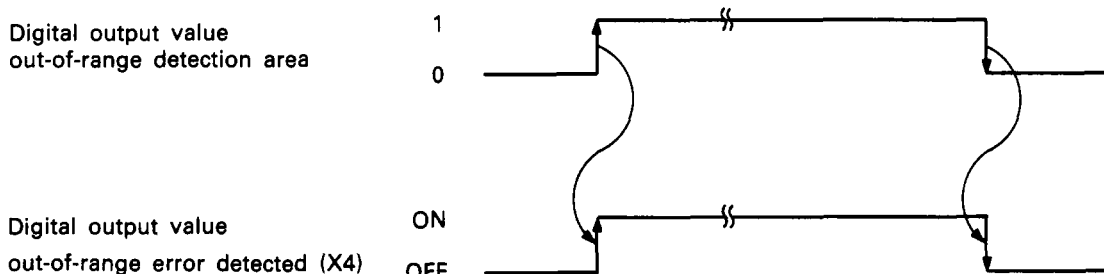

### (6) Detected temperature output value out-of-range (X5)

This signal is turned on if a single "1" is set in the buffer memory detected temperature value out-of-range detection area. The signal is turned off by writing "0" to the detected temperature value out-of-range detection area with the sequence program.

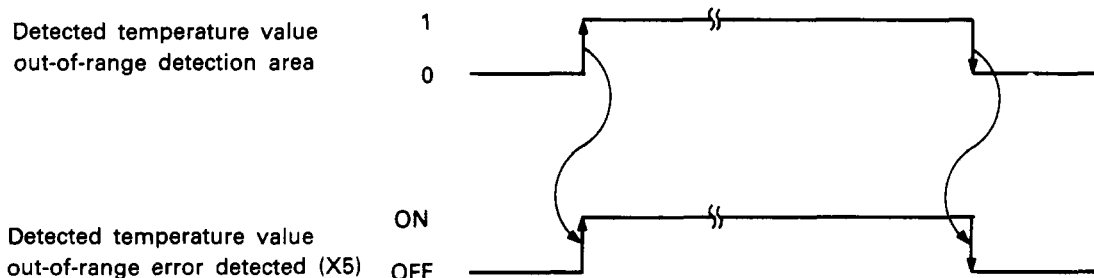

### (7) Detected temperature value LED display request signal (Y10)

When the detected temperature value LED display request signal is turned ON, the detected temperature of the channel specified by the A616TD INPUT switch and MX CH. switch is displayed on the LED display.

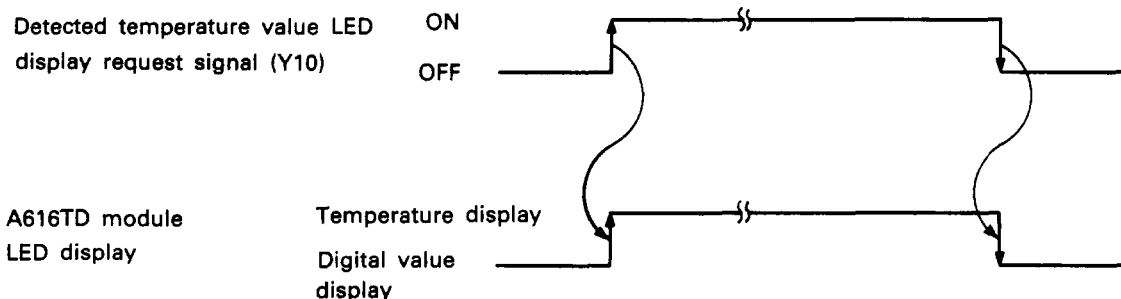

# 5. PROGRAMMING

## 5.2 Buffer Memory

The A616TD has a buffer memory for communication of data with the programmable controller (PC) CPU. The buffer memory has no battery back-up.

### 5.2.1 Buffer memory assignment

The buffer memory addresses are assigned as shown in the table below.

Address (Hexadecimal)		Write condition	Reference
0H	Data format selection	Random	Section 6.2.1
1H	Error code storage	Random	Section 5.12, Section 6.2.4
2H	Faulty A60MX <input type="checkbox"/> CONNECT NO. storage	Random	Section 5.11, Section 6.2.3
3H	Thermocouple-type setting error channel number storage	Random	Section 5.4.1
4H	Current sampling period storage	Write protected	Section 5.10
to	Not used	Write protected	—
FH	Conversion enable/ disable designation	Random	Section 5.4.2, Section 6.2.1
10H to 17H			
18H	Set data setting request	Random	Section 5.4.5, Section 6.2.1
to	Not used	Write protected	—
20H to 27H	Discontinuity detection enable/disable designation	Random	Section 5.4.3
to	Not used	Write protected	—
30H to 3FH	Temperature settings corresponding to digital output values	Random	Section 5.4.4
40H to 47H	Discontinuity detection channel number storage	Random	Section 5.9.1
to	Not used	Write protected	—
50H to 57H	Digital output value out-of-range channel number storage	Random	Section 5.9.2
to	Not used	Write protected	—
60H to 67H	Temperature output value out-of-range channel number storage	Random	Section 5.9.3
to	Not used	Write protected	—
70H to 7FH	Input channel digital output value storage	Write protected	Section 6.2.2
80H to FFH	Error compensation settings	Random	Section 5.5
100H to 17FH	Thermocouple-type settings	Random	Section 5.4.1
180H to 1FFH	MX CH. channel digital output value storage	Write protected	Section 5.6, Section 6.2.2
200H to 27FH	MX CH. channel detected temperature value storage	Write protected	Section 5.7

Random data read permitted from the above memory areas at all times.

#### IMPORTANT

The write-protected areas of the buffer memory are read-only areas for the sequence program. It is important that the sequence program does not write to these areas. If an attempt is made to write to a write-protected buffer memory area, error number 10 is displayed and the RUN LED flashes.

# 5. PROGRAMMING

## 5.3 Programming Procedure

An A616TD temperature/digital conversion program is written according to the following procedure:

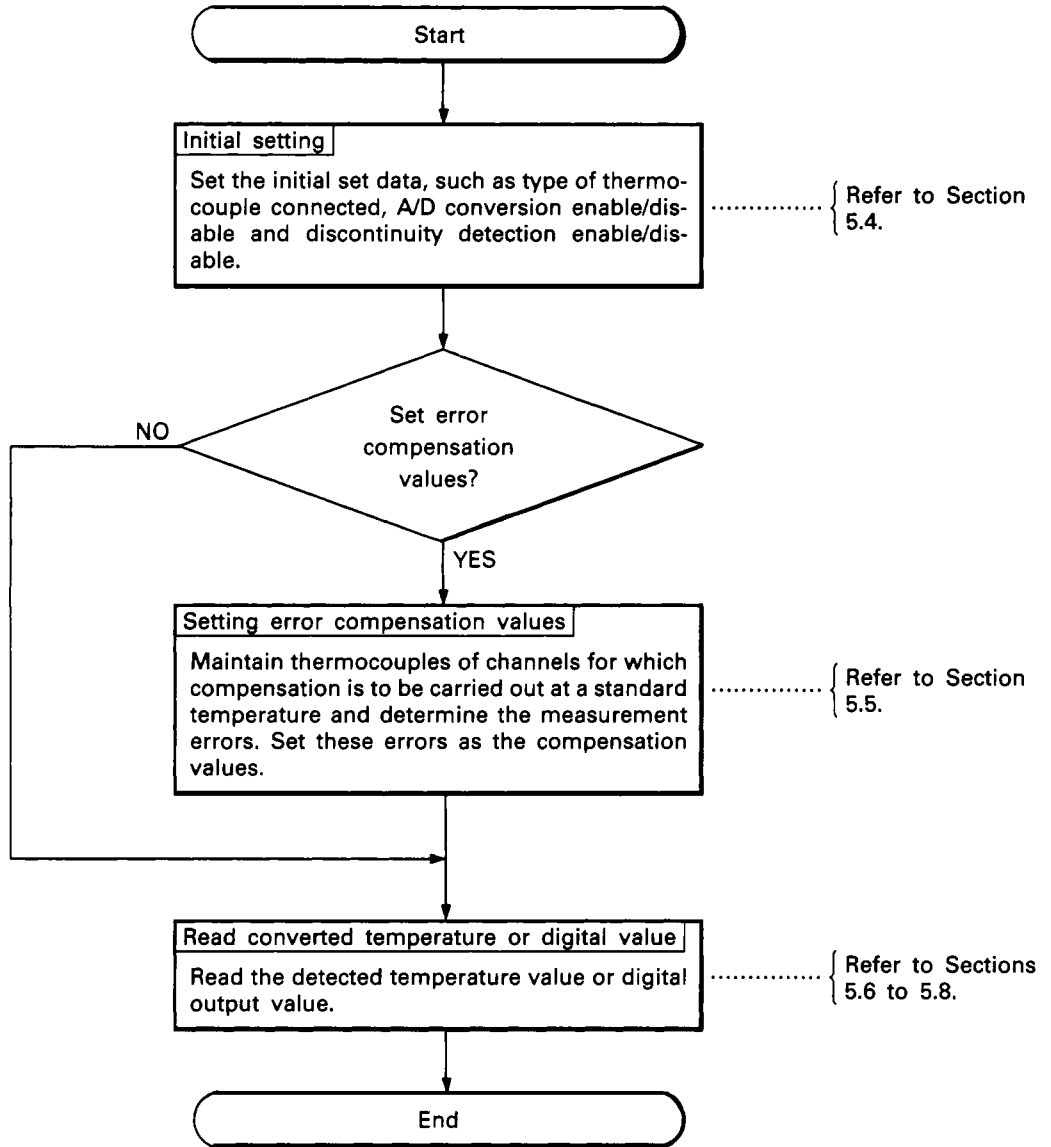

## 5. PROGRAMMING

### 5.4 Initial Setting

The initial setting program shown below must be included before any program to read detected temperature or digital output values.

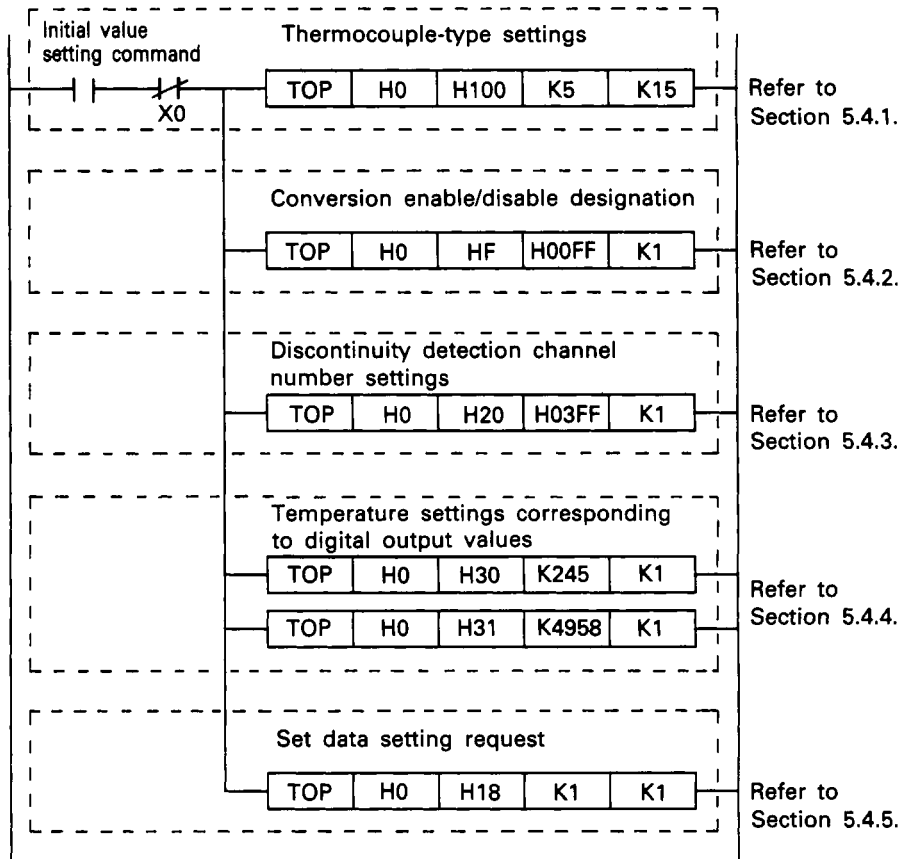

Always execute the set data setting request after setting the initial set data in the buffer memory.

The previously set data becomes valid and A/D conversion is carried out when this set data setting request instruction is executed.

# 5. PROGRAMMING

## 5.4.1 Setting the thermocouple types

Determine the setting value (0 to 8) appropriate for the type of thermocouple connected to each channel from Table 5.2 and write the values for each channel to the buffer memory addresses 100<sub>H</sub> to 17F<sub>H</sub>.

- (1) The setting value for each type of thermocouple is shown in the table below.

Standard	Type of Thermocouple								
	0	1	2	3	4	5	6	7	8
JIS	K	J	E	R	T	B	S	—	—
ANSI	K	J	E	R	T	B	S	—	—
BS	NiCr -NiAl	Fe -CuNi	NiCr -CuNi	PtRh13 -Pt	Cu -CuNi	PtRh30 -RtRh6	PtRh10 -Pt	—	—
DIN	NiCr -Ni	—	—	—	—	—	PtRh -Pt	Fe -CuNi	Cu -CuNi

Table 5.2 A60MXT Application Thermocouple List

- (2) The setting area of buffer memory addresses 100<sub>H</sub> to 17F<sub>H</sub> is configured as follows.

Address

100 <sub>H</sub>	CNT. No. 0	MX CH. 0	No setting required.
101 <sub>H</sub>		MX CH. 1	Thermocouple-type setting area
102 <sub>H</sub>		MX CH. 2	Thermocouple-type setting area
to		⋮	
10F <sub>H</sub>		MX CH. F	Thermocouple-type setting area
110 <sub>H</sub>	CNT. No. 1	MX CH. 0	No setting required.
111 <sub>H</sub>		MX CH. 1	Thermocouple-type setting area
112 <sub>H</sub>		MX CH. 2	Thermocouple-type setting area
to		⋮	
11F <sub>H</sub>		MX CH. F	Thermocouple-type setting area
to		⋮	
170 <sub>H</sub>	CNT. No. 7	MX CH. 0	No setting required.
171 <sub>H</sub>		MX CH. 1	Thermocouple-type setting area
172 <sub>H</sub>		MX CH. 2	Thermocouple-type setting area
to		⋮	
17F <sub>H</sub>		MX CH. F	Thermocouple-type setting area

CNT NO. refers to CONNECT number.

The relationship between the area addresses and channel numbers is as follows:

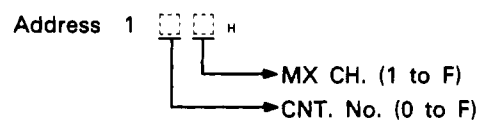

- (3) The default value of "0" is written to all channels when the power supply is turned on or the PC CPU reset.

## 5. PROGRAMMING

- (4) A setting error occurs if a value outside of the range 0 to 8 is written to the setting area. The error code 70 is written to the buffer memory address 1<sub>H</sub> and the channel number for which the setting error occurred is written to address 3<sub>H</sub> as a 2-digit hexadecimal value.

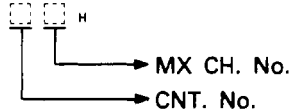

The channel number for which the setting error occurred remains stored in memory after the setting value is corrected within the range 0 to 8. Write "0" to the buffer memory address 1<sub>H</sub> with the sequence program to clear the detected data. (Refer to Section 5.12.)

### POINT

- (1) No settings can be made for MX CH. 0 for CNT NO. 0 to F as the cold-junction compensation thermoresistors (Pt100) are connected to these channels. Settings made for these channels are ignored.
- (2) A setting error occurs if a value outside of the range 0 to 8 is written to the setting area. In this case, the following occur:
  - a) The A616TD RUN LED flashes
  - b) The error code 70 is displayed on the A616TD LED display
  - c) Conversion is interrupted for the channel for which the out-of-range data was set.

## 5. PROGRAMMING

### 5.4.2 Specifying A/D conversion enable/disable

Write "0" or "1", respectively, to the buffer memory addresses F<sub>H</sub> to 17<sub>H</sub> to disable or enable A/D conversion for each A616TD and A60MXT channel. Refer to Section 6.2.1 (1) if A60MX and a A60MXR are to be connected for a combination of temperature/digital conversion and analog/digital conversion.

- (1) Default values are written to address F<sub>H</sub> when the power supply is turned on or the PC CPU reset to enable conversion for all channels. Values are written to the addresses 10<sub>H</sub> to 17<sub>H</sub> to enable conversion for all channels of CNT N. areas to which an A60MXT module is connected, and to disable conversion for all the CNT No. areas.
- (2) The 16-bit configuration of the memory area is shown below.

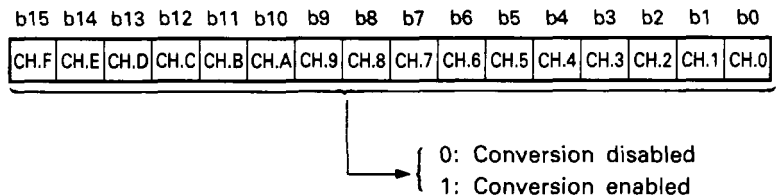

- (3) The setting area of buffer memory addresses F<sub>H</sub> to 17<sub>H</sub> is configured as follows.

Address

F <sub>H</sub>	A616TD INPUT 0 to F	Channel conversion enable/disable setting area
10 <sub>H</sub>	CNT. No. 0 MX CX. 0 to F	Channel conversion enable/disable setting area
11 <sub>H</sub>	CNT. No. 1 MX CX. 0 to F	Channel conversion enable/disable setting area
12 <sub>H</sub>	CNT. No. 2 MX CX. 0 to F	Channel conversion enable/disable setting area
13 <sub>H</sub>	CNT. No. 3 MX CX. 0 to F	Channel conversion enable/disable setting area
14 <sub>H</sub>	CNT. No. 4 MX CX. 0 to F	Channel conversion enable/disable setting area
15 <sub>H</sub>	CNT. No. 5 MX CX. 0 to F	Channel conversion enable/disable setting area
16 <sub>H</sub>	CNT. No. 6 MX CX. 0 to F	Channel conversion enable/disable setting area
17 <sub>H</sub>	CNT. No. 7 MX CX. 0 to F	Channel conversion enable/disable setting area

#### POINT

- (1) Channel 0 of the A60MXT is the reference temperature measurement channel. Therefore, if conversion is enabled for a single channel from CH.1 to CH.F, conversion is carried out regardless of the enable/disable setting for channel 0.
- (2) "0" (conversion disable) is automatically written to the CNT No. area for channels which are not connected with the A60MXT.
- (3) If conversion is enabled for channels which are not connected with the A60MXT, the setting is ignored.

## 5. PROGRAMMING

### 5.4.3 Specifying the discontinuity detection channels

The discontinuity detection function is specified for the thermocouples connected to the A60MXT by setting the switches (as described in Section 4.5) and writing the values "0" or "1" to the buffer memory addresses 20<sub>H</sub> to 27<sub>H</sub>.

- (1) The default values written to the buffer memory addresses when the power supply is turned on or the PC CPU reset, differ depending on the setting of the discontinuity detection enable switch, SW1.

ON : discontinuity detection enabled for all channels MX CH. 1 to F.  
 OFF : discontinuity detection disabled for all channels MX CH. 1 to F.

- (2) If discontinuity detection is to be enabled or disabled for all channels of the A60MXT, the default values are satisfactory, and no further settings are required.
- (3) However, if discontinuity detection is to be enabled for only some of the channels, these channels can be specified with the channel setting switches from switch 4 of SW1 to switch 8 of SW4. Turn the appropriate pair of switches for the channel ON to enable the discontinuity detection.
- (4) The 16-bit configuration of the memory area is shown below.

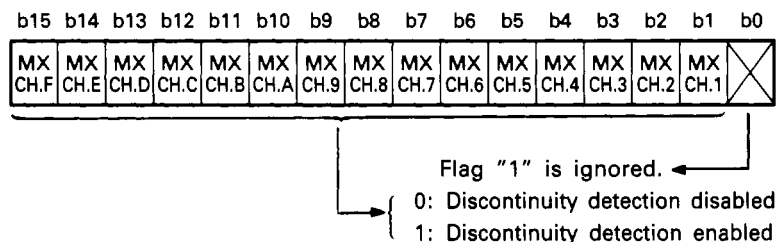

- (5) The setting area of buffer memory addresses 20<sub>H</sub> to 27<sub>H</sub> is configured as follows.

Address

20 <sub>H</sub>	CNT. No.0 MX CH. 1 to F	Discontinuity detection enable/disable setting area
21 <sub>H</sub>	CNT. No.1 MX CH. 1 to F	Discontinuity detection enable/disable setting area
22 <sub>H</sub>	CNT. No.2 MX CH. 1 to F	Discontinuity detection enable/disable setting area
23 <sub>H</sub>	CNT. No.3 MX CH. 1 to F	Discontinuity detection enable/disable setting area
24 <sub>H</sub>	CNT. No.4 MX CH. 1 to F	Discontinuity detection enable/disable setting area
25 <sub>H</sub>	CNT. No.5 MX CH. 1 to F	Discontinuity detection enable/disable setting area
26 <sub>H</sub>	CNT. No.6 MX CH. 1 to F	Discontinuity detection enable/disable setting area
27 <sub>H</sub>	CNT. No.7 MX CH. 1 to F	Discontinuity detection enable/disable setting area

#### POINT

The following occur if the contents of the buffer memory differ from the switch settings:

**Buffer memory enabled, switch setting disabled: discontinuity not detected.**

**Buffer memory disabled, switch setting enabled: errors in detected temperature values.**



## 5. PROGRAMMING

### 5.4.4 Setting the temperatures corresponding to digital output values

Determine the measured temperatures for each channel corresponding to a digital output value of 0 and 4000, respectively, and write the values to the buffer memory addresses 30<sub>H</sub> to 3F<sub>H</sub>.

- (1) Default temperature values for a digital output of 0 and 4000, which depend on the measurement range, are written to the buffer memory when the power supply is turned on or the PC CPU reset, as shown in Table 5.3.

Measurement Range \ Digital Value	1	2	3	4
0	-2000 ( $\times 10^{-1}^{\circ}\text{C}$ )	0 ( $\times 10^{-1}^{\circ}\text{C}$ )	0 ( $\times 10^{-1}^{\circ}\text{C}$ )	0 ( $\times 10^{-1}^{\circ}\text{C}$ )
4000	3000 ( $\times 10^{-1}^{\circ}\text{C}$ )	10000 ( $\times 10^{-1}^{\circ}\text{C}$ )	10000 ( $\times 10^{-1}^{\circ}\text{C}$ )	10000 ( $\times 10^{-1}^{\circ}\text{C}$ )

Table 5.3 Temperature Settings Corresponding to Digital Output Values

- (2) Write the required setting temperatures to buffer memory addresses 30<sub>H</sub> to 3F<sub>H</sub> to set temperatures other than the default temperatures to correspond to digital output values of 0 and 4000.
- (3) The temperatures are input to the first decimal place, by using the setting values as follows:

$$\text{Setting value} = \text{Temperature value to the first decimal place} \times 10$$

#### Example

To set a temperature of 23.5°C, use a setting value of  $23.5 \times 10 = 235$ .

- (4) The setting area of buffer memory addresses 30<sub>H</sub> to 3F<sub>H</sub> is configured as follows.

Address

30 <sub>H</sub>	INPUT 0	Temperature setting value (corresponding to a digital value of 0).
31 <sub>H</sub>		Temperature setting value (corresponding to a digital value of 4000).
32 <sub>H</sub>	INPUT 1	Temperature setting value (corresponding to a digital value of 0).
33 <sub>H</sub>		Temperature setting value (corresponding to a digital value of 4000).
34 <sub>H</sub>	INPUT 2	Temperature setting value (corresponding to a digital value of 0).
35 <sub>H</sub>		Temperature setting value (corresponding to a digital value of 4000).
36 <sub>H</sub>	INPUT 3	Temperature setting value (corresponding to a digital value of 0).
37 <sub>H</sub>		Temperature setting value (corresponding to a digital value of 4000).
38 <sub>H</sub>	INPUT 4	Temperature setting value (corresponding to a digital value of 0).
39 <sub>H</sub>		Temperature setting value (corresponding to a digital value of 4000).
3A <sub>H</sub>	INPUT 5	Temperature setting value (corresponding to a digital value of 0).
3B <sub>H</sub>		Temperature setting value (corresponding to a digital value of 4000).
3C <sub>H</sub>	INPUT 6	Temperature setting value (corresponding to a digital value of 0).
3D <sub>H</sub>		Temperature setting value (corresponding to a digital value of 4000).
3E <sub>H</sub>	INPUT 7	Temperature setting value (corresponding to a digital value of 0).
3F <sub>H</sub>		Temperature setting value (corresponding to a digital value of 4000).

## 5. PROGRAMMING

- (5) The settings of the temperatures which correspond to the digital outputs of 0 and 4000 determine the temperature/digital conversion characteristics.

### Example

The temperature measurement range is 0 to 500°C for a JIS standard, K type thermocouple with the A60MXT measurement range set to "2". The temperature/digital conversion characteristic is as shown below if a temperature of 50°C is set to correspond to a digital output value of 0 and a temperature of 450°C is set to correspond to a digital output value of 4000.

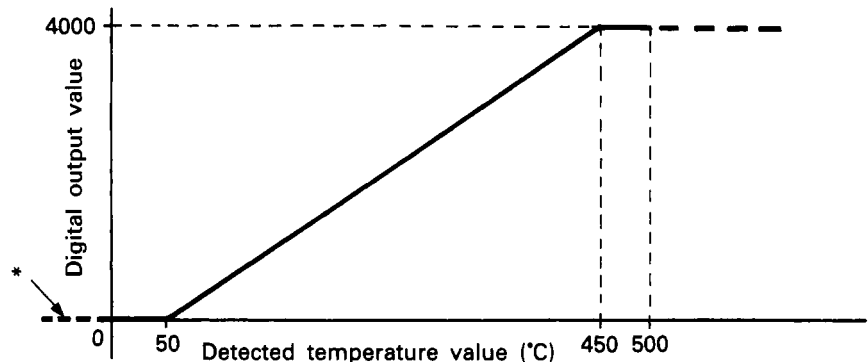

Avoid operation in the areas indicated with dotted lines as they do not meet accuracy specifications.

- (6) When temperatures set to correspond to digital output values of 0 and 4000 are set outside of the temperature measurement range, the digital values corresponding to temperature input values lying outside of the temperature measurement range are interpolated proportional to the temperature input, providing that the value lies inside of the permitted measurement range shown in the table below.

However, if the temperature exceeds the maximum or minimum temperature limit of the permitted temperature range, the digital value is fixed at the value corresponding to the maximum or minimum temperature limit, respectively.

JIS Standard	ANSI Standard	DIN Standard	BS Standard	Measurement Range	1	2	3	4
B	B	—	PtRh30 -PtRh6	Temperature measurement range (°C)		100 to 1800		
				Permitted temperature range (°C)		44 to 1820		
R	R	—	PtRh13 -Pt	Temperature measurement range (°C)		0 to 1700		
				Permitted temperature range (°C)		0 to 1769		
S	S	PtRh -Pt	PtRh10 -Pt	Temperature measurement range (°C)		0 to 1700		
				Permitted temperature range (°C)		0 to 1769		
K	K	NiCr -Ni	NiCr -NiAl	Temperature measurement range (°C)	-200 to 250	0 to 500	0 to 1000	0 to 1300
				Permitted temperature range (°C)	-270 to 307	0 to 602	0 to 1232	0 to 1372
E	E	—	NiCr -CuNi	Temperature measurement range (°C)	-200 to 150	0 to 300	0 to 600	0 to 1000
				Permitted temperature range (°C)	-270 to 187	0 to 350	0 to 661	0 to 1000
J	J	—	Fe -CuNi	Temperature measurement range (°C)	-200 to 200	0 to 400	0 to 800	0 to 1200
				Permitted temperature range (°C)	-210 to 231	0 to 457	0 to 870	0 to 1200
T	T	—	Cu -CuNi	Temperature measurement range (°C)	-200 to 200	0 to 400		
				Permitted temperature range (°C)	-270 to 258	0 to 400		
—	—	Fe -CuNi	—	Temperature measurement range (°C)		0 to 400	0 to 800	0 to 900
				Permitted temperature range (°C)		0 to 450	0 to 855	0 to 900
—	—	Cu -CuNi	—	Temperature measurement range (°C)		0 to 400	0 to 600	
				Permitted temperature range (°C)		0 to 463	0 to 600	

## 5. PROGRAMMING

For a JIS standard, K type thermocouple with the A60MXT measurement range set to "1," the following temperature ranges apply:

Temperature measurement range :  $-200$  to  $250^{\circ}\text{C}$   
Permitted temperature range :  $-270$  to  $307^{\circ}\text{C}$

- ① A temperature of  $-200^{\circ}\text{C}$  is set to correspond to a digital output value of 0 and a temperature of  $400^{\circ}\text{C}$  is set to correspond to a digital output value of 4000.
- ② A temperature of  $-300^{\circ}\text{C}$  is set to correspond to a digital output value of 0 and a temperature of  $250^{\circ}\text{C}$  is set to correspond to a digital output value of 4000.

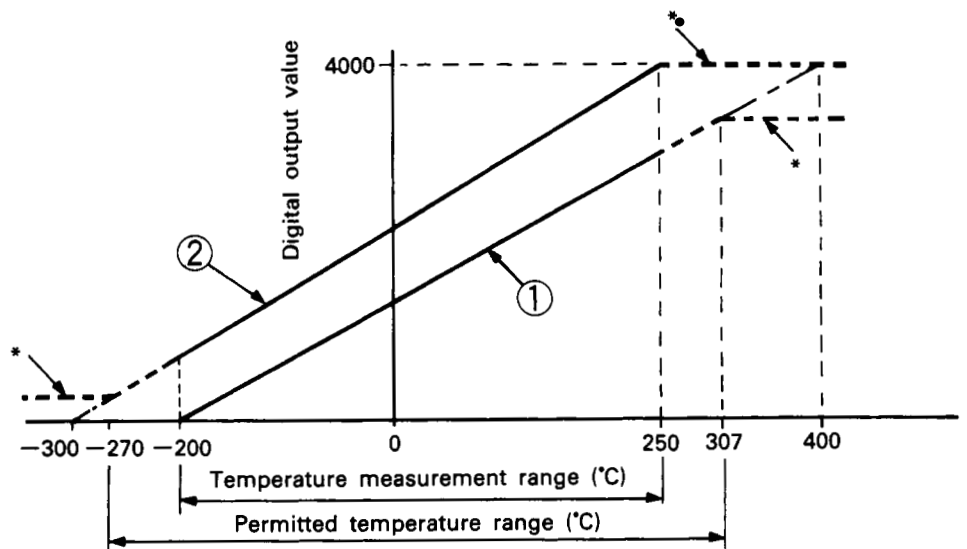

\*Avoid operation in the areas indicated with dotted lines as they do not meet accuracy specifications.

## 5. PROGRAMMING

### 5.4.5 Set data setting request

"1" must be written to buffer memory address 18<sub>H</sub> when set data (such as A/D conversion enable/disable, temperature settings corresponding to digital output values, etc.) has been written to the buffer memory during initial setting or temperature/digital conversion operation.

When "1" is written to this area, the A/D conversion ready signal is turned off, the set data is written from the buffer memory to the set data memory, all channel data is checked, and the A/D conversion ready signal is turned on to start A/D conversion.

- (1) After making the initial settings, A/D conversion cannot be started until "1" is written to this area.
- (2) The "1" written to the set data setting area is automatically reset to "0" when the A/D conversion ready signal is turned on.
- (3) The set data setting request signal and A/D conversion ready signal are turned on and off as shown below.

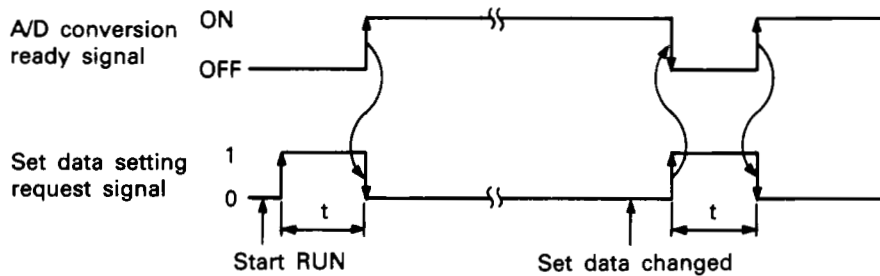

$t$  = sampling period (ms) (Refer to Section 3.3.2.)

- (4) "1" must be written to this area after the set data is changed during A/D conversion operation or A/D conversion continues with the previous values.  
During A/D conversion, write the "1" to memory by sending a TO instruction as a pulsed TOP instruction.  
Error 13 occurs if "1" is written continuously using a TO instruction.
- (5) A setting error occurs and the error code 12 is written to buffer memory address 1<sub>H</sub> if an attempt is made to write a value other than "1" to the setting area. The operation status is then as follows:

During initial setting: A/D conversion is not executed.

During A/D conversion: Processing continues with the previous conditions.

After the correct value is written, the error code should be cleared by writing "0" from the sequence program to the buffer memory address 1<sub>H</sub>.

(Refer to Section 5.12.)

## 5. PROGRAMMING

---

### POINT

Always write "1" to the set data setting area with a TOP instruction executed for one scan only.  
An error occurs and processing stops if "1" is written continuously with the TO instruction.

## 5. PROGRAMMING

---

### 5.5 Error Compensation Settings

Maintain thermocouples of channels for which compensation is to be carried out at a standard temperature and determine the errors between the measured and standard temperatures. Set these errors as the compensation values in the buffer memory addresses 80<sub>h</sub> to FF<sub>h</sub>.

#### (1) Measuring the standard temperature

- (a) Turn on the detected temperature value LED display request signal (Y10) and specify the channel for which the standard temperature is to be measured with the A616TD INPUT and MX CH. switches.
- (b) Maintain the thermocouple connected to this channel at the standard temperature and read the measured value from the LED display.
- (c) The standard temperature must lie within the temperature measurement range.

#### (2) Determining the error compensation values

- (a) Use the Thermoelectromotive Force Table in Appendix 1 to determine the thermoelectromotive force  $V_{st}$  ( $\mu V$ ) produced by the thermocouple at the standard temperature and the thermoelectromotive force  $V_{mt}$  ( $\mu V$ ) obtained at the measured temperature (indicated on the LED display).
- (b) Determine the difference between these two thermoelectromotive force values and set this difference as the error compensation value.

$$\text{Error compensation value} = V_{mt} - V_{st}$$

## 5. PROGRAMMING

### Example

If a temperature of 2°C is displayed the A616TD LED display using a JIS standard K type thermocouple at a standard temperature of 0°C.

The thermoelectromotive forces are:

0 μV at 0°C (Vst)

79 μV at 2°C (Vmt)

The error compensation value is therefore:

$$79 - 0 = 79 \mu\text{V} (V_{mt} - V_{st})$$

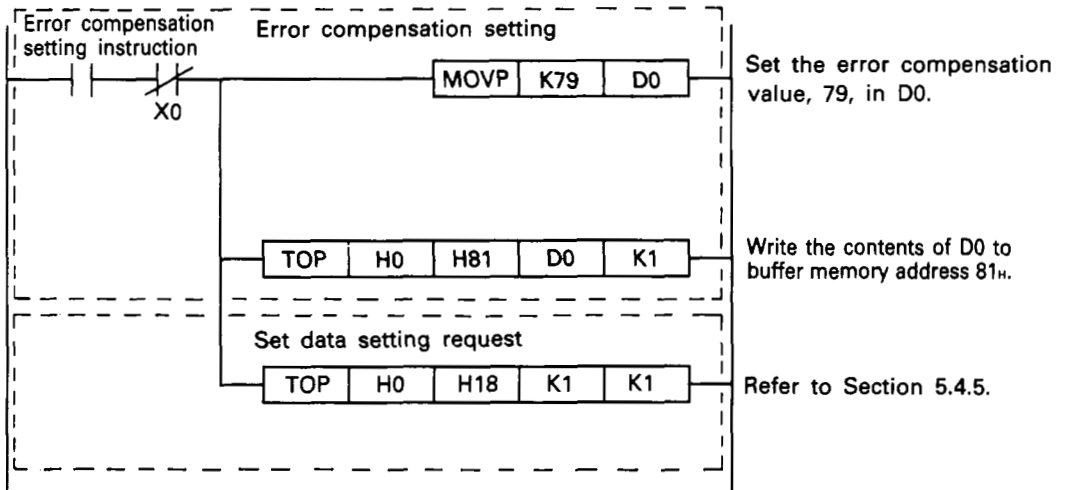

### (3) Setting range for error compensation values

Set the error compensation value in the range  $-4000$  to  $4000 \mu\text{V}$ .

The accuracy of output data cannot be guaranteed if the error compensation value lies outside this range.

### (4) The default value of "0" is written for all channels when the power supply is turned on or the PC CPU reset.

## 5. PROGRAMMING

- (5) The setting area of buffer memory addresses 80<sub>H</sub> to FF<sub>H</sub> is configured as follows.

Address

80 <sub>H</sub>	CNT. No. 0	MX CH. 0	No setting required.
81 <sub>H</sub>		MX CH. 1	Error compensating value setting area
82 <sub>H</sub>		MX CH. 2	Error compensating value setting area
to			⋮
8F <sub>H</sub>		MX CH. F	Error compensating value setting area
90 <sub>H</sub>	CNT. No. 1	MX CH. 0	No setting required.
91 <sub>H</sub>		MX CH. 1	Error compensating value setting area
92 <sub>H</sub>		MX CH. 2	Error compensating value setting area
to			⋮
9F <sub>H</sub>		MX CH. F	Error compensating value setting area
to		⋮	
F0 <sub>H</sub>	CNT. No. 7	MX CH. 0	No setting required.
F1 <sub>H</sub>		MX CH. 1	Error compensating value setting area
F2 <sub>H</sub>		MX CH. 2	Error compensating value setting area
to			⋮
FF <sub>H</sub>		MX CH. F	Error compensating value setting area

The relationship between the area addresses and channel numbers is as follows:

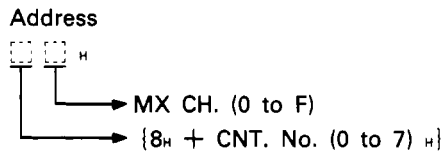

Example

Address of MX CH.8 of the CNT NO. 5 A60MXT module:

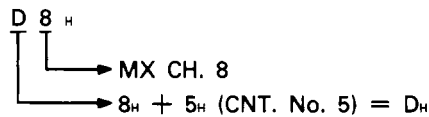

### POINT

No settings are required for MX CH. 0 as the cold-junction compensation thermoresistors (Pt100) are connected to these channels. Settings made for these channels are ignored.



# 5. PROGRAMMING

## 5.6 Reading the Digital Output Values

The temperatures input to the A60MXT channels from the temperature sensors are sampled and temperature/digital conversion is carried out for each channel. The digital output values are linearized and stored for each channel in the buffer memory addresses 180<sub>H</sub> - 1FF<sub>H</sub>.

The digital output value can be read by the PC CPU for any channel by specifying the buffer memory address.

- (1) The 16-bit configuration of the memory area for storage of MX CH. channel digital output values is shown below.

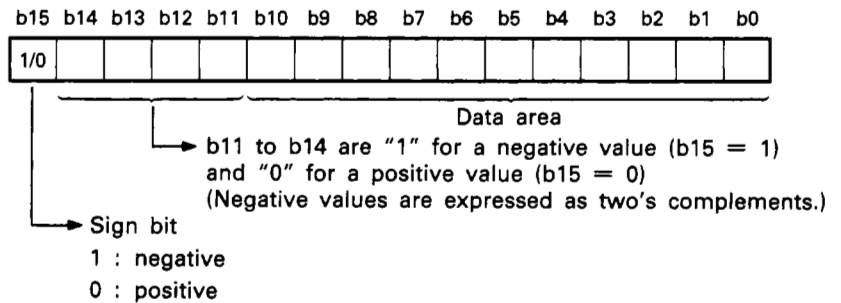

- (2) The buffer memory addresses 180<sub>H</sub> - 1FF<sub>H</sub> for storage of digital output values are configured as follows.

Address

180 <sub>H</sub>	CNT. No. 0	MX CH. 0	Digital output value
181 <sub>H</sub>		MX CH. 1	Digital output value
182 <sub>H</sub>		MX CH. 2	Digital output value
to		⋮	
18F <sub>H</sub>		MX CH. F	Digital output value
190 <sub>H</sub>	CNT. No. 1	MX CH. 0	Digital output value
191 <sub>H</sub>		MX CH. 1	Digital output value
192 <sub>H</sub>		MX CH. 2	Digital output value
to		⋮	
19F <sub>H</sub>		MX CH. F	Digital output value
to	⋮		
1F0 <sub>H</sub>	CNT. No. 7	MX CH. 0	Digital output value
1F1 <sub>H</sub>		MX CH. 1	Digital output value
1F2 <sub>H</sub>		MX CH. 2	Digital output value
to		⋮	
1FF <sub>H</sub>		MX CH. F	Digital output value

The relationship between the area addresses and channel numbers is as follows:

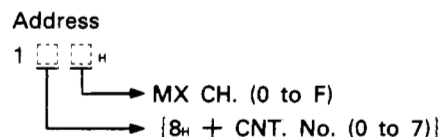

Example

Address of MX CH. 2 of the CNT NO. 7 A60MXT module:

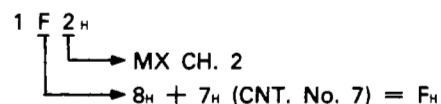

## 5. PROGRAMMING

- (3) "0" is always written for MX CH. 0 of CNT NO. 0 to 7 as the cold-junction compensation thermoresistors (Pt100) are connected to these channels.
- (4) Program example  
Normal read of the digital output values from channels 1 to F of the A60MXT module connected to channel 1 of the A616TD module to addresses D0 to D14.

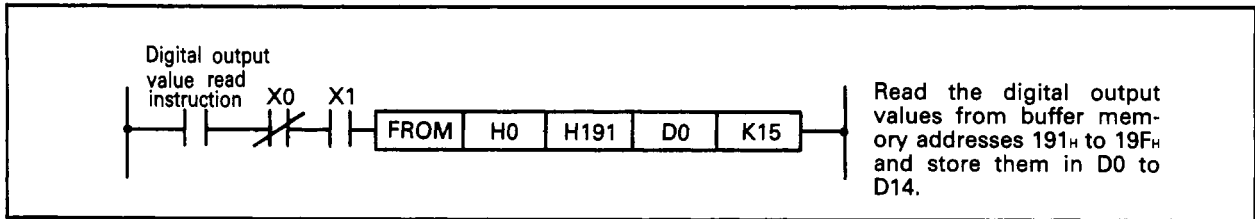

## 5. PROGRAMMING

### 5.7 Reading the Detected Temperature Values

The temperatures input to the A60MXT channels from the temperature sensors are converted to detected temperature values for each channel and stored in the buffer memory addresses 200<sub>h</sub> to 27F<sub>h</sub>.

The detected temperature value can be read by the PC CPU for any channel by specifying the buffer memory address.

- (1) The values stored in the buffer memory are ten times the temperature in Celsius.

Example

49.3°C is stored as  $49.3 \times 10 = \underline{493}$ .  
Storage data

- (2) The 16-bit configuration of the memory area for storage of detected temperature values is shown below.

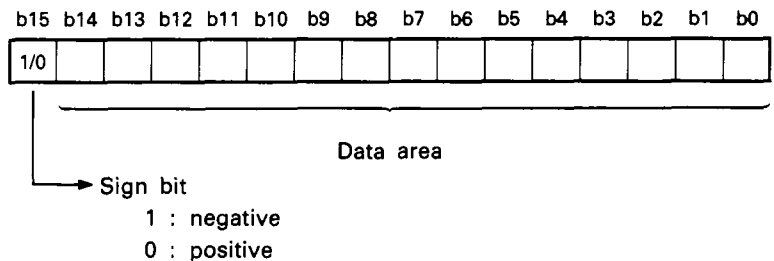

## 5. PROGRAMMING

- (3) The buffer memory addresses 200<sub>H</sub> to 27F<sub>H</sub> for storage of detected temperature values are configured as follows.

Address

200 <sub>H</sub>	CNT. No. 0	MX CH. 0	Detected temperature value
201 <sub>H</sub>		MX CH. 1	Detected temperature value
202 <sub>H</sub>		MX CH. 2	Detected temperature value
to		⋮	
20F <sub>H</sub>		MX CH. F	Detected temperature value
210 <sub>H</sub>	CNT. No. 1	MX CH. 0	Detected temperature value
211 <sub>H</sub>		MX CH. 1	Detected temperature value
212 <sub>H</sub>		MX CH. 2	Detected temperature value
to		⋮	
21F <sub>H</sub>		MX CH. F	Detected temperature value
to	⋮		
270 <sub>H</sub>	CNT. No. 7	MX CH. 0	Detected temperature value
271 <sub>H</sub>		MX CH. 1	Detected temperature value
272 <sub>H</sub>		MX CH. 2	Detected temperature value
to		⋮	
27F <sub>H</sub>		MX CH. F	Detected temperature value

The relationship between the area addresses and channel numbers is as follows:

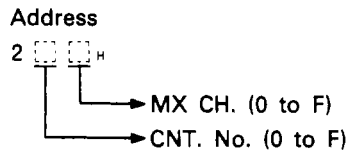

### Example

Address of MX CH. F of the CNT NO. 1 A60MXT module:

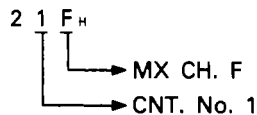

- (4) The terminal block temperature is always stored for MX CH. 0 of CNT NO. 0 to 7

## 5. PROGRAMMING

### 5.8 Detected Temperature Value Celsius - Fahrenheit Conversion Program

A program to convert the detected temperature value stored in the buffer memory addresses 200<sub>H</sub> - 27F<sub>H</sub> as a value equal to ten times the Celsius temperature (°C) can be converted to a value equal to ten times the Fahrenheit temperature (°F) using the program listed below.

(1) Conversion formula

Detected temperature value = Celsius temperature × 10

Fahrenheit temperature = Celsius temperature × 1.8 + 32

$$= \frac{\text{Detected temperature value}}{10} \times 1.8 + 32$$

$$\text{Therefore, Fahrenheit temperature} \times 10 = \frac{\text{Detected temperature value} \times 18}{10} + 320$$

Multiplying the temperature by ten permits handling of the temperature to the first decimal place.

(2) Program example

Store the detected temperature value from MX CH. 1 of the A60MXT connected to A616TD INPUT 0 into D50. Convert this value to Fahrenheit and store the converted value in D60.

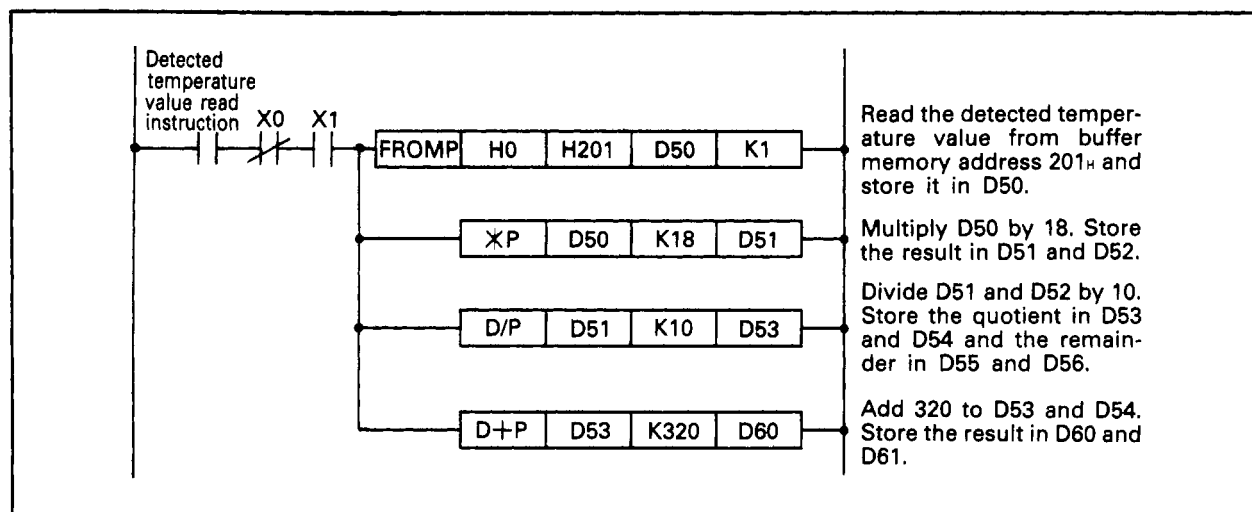

## 5. PROGRAMMING

### 5.9 External Fault Detection

External fault data is stored to the buffer memory if a discontinuity occurs in a thermocouple or compensation lead, or if an abnormal temperature value is input.

#### 5.9.1 Reading the faulty channel number

When a discontinuity is detected in a thermocouple or compensation lead, "1" is written to the bit of addresses 40<sub>H</sub> to 47<sub>H</sub> of buffer memory which corresponds to the channel for which the fault was detected.

(1) When a discontinuity is detected for any of the A60MXT channels for which discontinuity detection is enabled, "1" is written to the bit which corresponds to the channel and the discontinuity error signal X3 is turned on.

(2) The 16-bit configuration of the memory area is shown below.

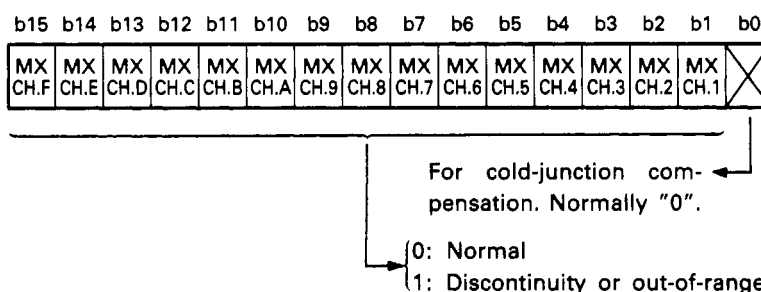

(3) The storage area in buffer memory addresses 40<sub>H</sub> to 47<sub>H</sub> is configured as follows.

Address

40 <sub>H</sub>	CNT. No.0 MX CH. 1 to F	Channel for which discontinuity detected
41 <sub>H</sub>	CNT. No.1 MX CH. 1 to F	Channel for which discontinuity detected
42 <sub>H</sub>	CNT. No.2 MX CH. 1 to F	Channel for which discontinuity detected
43 <sub>H</sub>	CNT. No.3 MX CH. 1 to F	Channel for which discontinuity detected
44 <sub>H</sub>	CNT. No.4 MX CH. 1 to F	Channel for which discontinuity detected
45 <sub>H</sub>	CNT. No.5 MX CH. 1 to F	Channel for which discontinuity detected
46 <sub>H</sub>	CNT. No.6 MX CH. 1 to F	Channel for which discontinuity detected
47 <sub>H</sub>	CNT. No.7 MX CH. 1 to F	Channel for which discontinuity detected

(4) This data remains stored in buffer memory after the cause of the fault has been corrected. Write "0" to the buffer memory addresses 40<sub>H</sub> to 47<sub>H</sub> with a sequence program to clear the external fault data. (Refer to Section 5.12.)

## 5. PROGRAMMING

### 5.9.2 Reading the digital output value out-of-range channel number

If a temperature is input which exceeds the range specified by the temperatures set to correspond to digital output values (refer to Section 5.4.4), "1" is written to the bit of addresses 50<sub>H</sub> to 57<sub>H</sub> of buffer memory which corresponds to the channel for which the out-of-range temperature was detected.

- (1) If a temperature is input which exceeds the temperature value range specified by the temperatures set to correspond to digital output values (refer to Section 5.4.4), "1" is written to the bit which corresponds to the channel for which the out-of-range temperature was detected and the digital output value out-of-range error signal X4 is turned on.
- (2) The 16-bit configuration of the memory area is shown below.

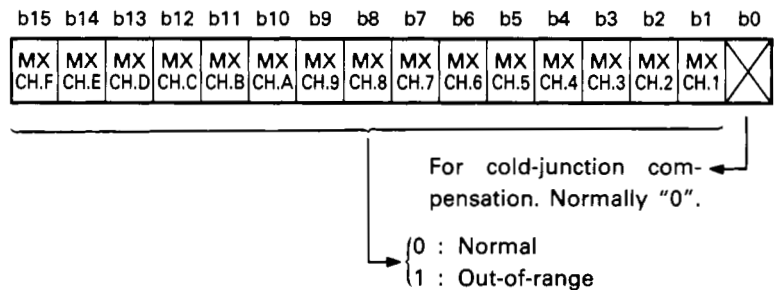

- (3) The storage area in buffer memory addresses 50<sub>H</sub> to 57<sub>F<sub>H</sub></sub> is configured as follows.

Address

50 <sub>H</sub>	CNT. No.0	MX CH. 1 to F	Channel for which out-of-range value detected
51 <sub>H</sub>	CNT. No.1	MX CH. 1 to F	Channel for which out-of-range value detected
52 <sub>H</sub>	CNT. No.2	MX CH. 1 to F	Channel for which out-of-range value detected
53 <sub>H</sub>	CNT. No.3	MX CH. 1 to F	Channel for which out-of-range value detected
54 <sub>H</sub>	CNT. No.4	MX CH. 1 to F	Channel for which out-of-range value detected
55 <sub>H</sub>	CNT. No.5	MX CH. 1 to F	Channel for which out-of-range value detected
56 <sub>H</sub>	CNT. No.6	MX CH. 1 to F	Channel for which out-of-range value detected
57 <sub>H</sub>	CNT. No.7	MX CH. 1 to F	Channel for which out-of-range value detected

- (4) This data remains stored in buffer memory after the cause of the fault has been corrected. Write "0" to the buffer memory addresses 50<sub>H</sub> to 57<sub>F<sub>H</sub></sub> with a sequence program to clear the external fault data. (Refer to Section 5.12.)

## 5. PROGRAMMING

### 5.9.3 Reading the detected temperature value out-of-range channel number

If a temperature is input which exceeds the range specified by the measurement range setting, "1" is written to the bit of addresses 60<sub>H</sub> to 67<sub>H</sub> of buffer memory which corresponds to the channel for which the out-of-range temperature was detected.

- (1) If a temperature is input which exceeds the measurement range setting (refer to Section 4.4), "1" is written to the bit which corresponds to the channel for which the out-of-range temperature was detected and the detected temperature value out-of-range error signal X5 is turned on.
- (2) A detected temperature value out-of-range error is also detected in the case of a discontinuity detection error, so that "1" is also written to the bit which corresponds to the channel in this case.
- (3) The 16-bit configuration of the memory area is shown below.

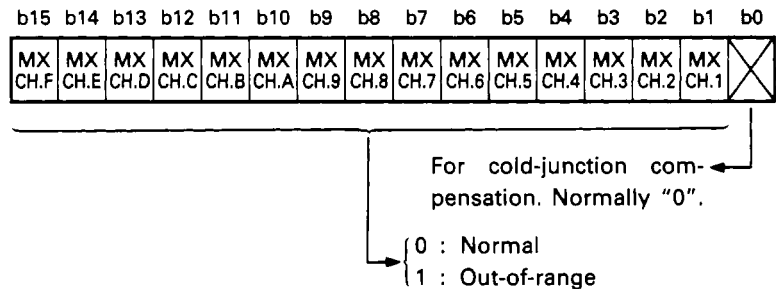

- (3) The storage area in buffer memory addresses 60<sub>H</sub> to 67<sub>H</sub> is configured as follows.

Address

60 <sub>H</sub>	CNT. No.0 MX CH. 1 to F	Channel for which out-of-range value detected
61 <sub>H</sub>	CNT. No.1 MX CH. 1 to F	Channel for which out-of-range value detected
62 <sub>H</sub>	CNT. No.2 MX CH. 1 to F	Channel for which out-of-range value detected
63 <sub>H</sub>	CNT. No.3 MX CH. 1 to F	Channel for which out-of-range value detected
64 <sub>H</sub>	CNT. No.4 MX CH. 1 to F	Channel for which out-of-range value detected
65 <sub>H</sub>	CNT. No.5 MX CH. 1 to F	Channel for which out-of-range value detected
66 <sub>H</sub>	CNT. No.6 MX CH. 1 to F	Channel for which out-of-range value detected
67 <sub>H</sub>	CNT. No.7 MX CH. 1 to F	Channel for which out-of-range value detected

- (4) This data remains stored in buffer memory after the cause of the fault has been corrected. Write "0" to the buffer memory addresses 60<sub>H</sub> to 67<sub>H</sub> with a sequence program to clear the external fault data. (Refer to Section 5.12.)



## 5. PROGRAMMING

### 5.10 Reading the Current Sampling Period

The sampling period is determined by multiplying the number of conversion channels for the A60MXT module with the largest number of conversion channels enabled by 50 milliseconds (refer to Section 3.3.2). The value is stored in buffer memory address 4<sub>H</sub>.

- (1) The value of the sampling period is upgraded each time the number of A60MXT channels for which conversion is enabled is changed.
- (2) The sampling period is stored in this area in millimeters.

#### Example

A sampling period of 800ms is stored as the value 800.

- (3) "0" is stored in this area if conversion is disabled for all channels of all A60MX[ ] units connected to the A616TD, or if the A616TD is used alone.

### 5.11 Reading Error Codes

When the A616TD detects an error, the corresponding error code is stored in buffer memory address 1<sub>H</sub> as a binary code.

- (1) The stored error code is upgraded each time an error is detected, and the previous value is cleared.
- (2) If an error occurs which results in an error code from 01 to 04, such as a faulty A60MXT module or a setting error, "1" is written to the bit of the buffer memory address 2<sub>H</sub> which corresponds to the CNT NO. of the faulty module. "1" is written to this address for the appropriate CNT. NO. each time a new error occurs, and this data remains stored until the area is cleared.

- 1) The 16-bit configuration of the memory area is shown below.

b15	b14	b13	b12	b11	b10	b9	b8	b7	b6	b5	b4	b3	b2	b1	b0
CNT.No.	CNT.No.	CNT.No.	CNT.No.	CNT.No.	CNT.No.	CNT.No.	CNT.No.	CNT.No.	CNT.No.	CNT.No.	CNT.No.	CNT.No.	CNT.No.	CNT.No.	CNT.No.
F	E	D	C	B	A	9	8	7	6	5	4	3	2	1	0

└─ 0 : Normal  
    1 : Discontinuity or out-of-range

### 5.12 Clearing the Error Code Area

- (1) This data remains stored in buffer memory after the causes of the faults have been corrected. Write "0" to the buffer memory addresses 1<sub>H</sub> and 2<sub>H</sub> with a sequence program to clear the error data.

## 5. PROGRAMMING

### 5.13 Programming for ACPU Remote I/O Station

When the A616TD is used on a remote I/O station, the master station (ACPU) should be programmed as described below.

#### 5.13.1 Programming instructions

The ACPU is controlled in direct or refresh I/O mode but data communication with a remote I/O station is made in batch refresh mode after the **END** (FEND) instruction is executed.

For full information on data link, see the Data Link System User's Manual.

- (1) Control timing must be noted. Since data is controlled via the link module, some delay may occur for communication of control data between the master station CPU and the A616TD on the remote I/O station.
- (2) The following instructions are used for data communication with the A616TD on the remote I/O station:

Data write from master station to remote I/O station A616TD:

**RTOP** instruction

Data read from remote I/O station A616TD to master station:

**RFRP** instruction

Data transfer between the master station CPU and A616TD is made by the link register (W). Hence, an appropriate program should be written so that the link register data is transferred to the other device after the **RFRP** instruction has been executed, and the required data is transferred to the link register before the **RTOP** instruction is executed.

- (3) The **RTOP** and **RFRP** instructions cannot be executed at the same time (within one scan) to one A616TD on the remote I/O station.

The signals on the following page must be used with the **RTOP** and **RFRP** instructions as interlock conditions.

The I/O signal numbers indicated are those assigned by the master station and correspond to X0 and Y1F in this example.

- (4) Control signals to remote I/O station

- Y□□ may not be provided to the remote I/O station by PLS Y□□ because of the relation between the master station scan time and link scan time.
- After the **SET** instruction is executed, the pulse output for executing the **RST** instruction cannot be used because data communication between the master station and remote I/O station is made in batch refresh mode after the **END** (FEND) instruction is executed.

# 5. PROGRAMMING

Signal Direction: PC CPU to A616TD		Signal Direction: A616TD to PC CPU	
Device number	Signal	Device number	Signal
Y <sub>0</sub> to Y <sub>c</sub>	Reserved.	X <sub>10</sub> to X <sub>1c</sub>	Reserved.
Y <sub>d</sub>	Used to switch off X <sub>1d</sub> .	X <sub>1d</sub>	Switched on if the <b>RFRP</b> or <b>RTOP</b> instruction cannot be executed due to a special function module fault.
Y <sub>e</sub>	Switched on by the master station CPU when the <b>RFRP</b> instruction is executed (data is transferred from the master station CPU to the link module). Must be reset by the user program after checking that X <sub>1e</sub> is on.	X <sub>1e</sub>	Switched on while the <b>RFRP</b> instruction is executed by the A616TD on the remote I/O station.
Y <sub>f</sub>	Switched on by the master station CPU when the <b>RTOP</b> instruction is executed (data is transferred from the master station CPU to the link module). Must be reset by the user program after checking that X <sub>1f</sub> is on.	X <sub>1f</sub>	Switched on while the <b>RTOP</b> instruction is executed by the A616TD on the remote I/O station.

## Timing

**RTOP**, **RFRP** instruction cannot be executed due to a special function module fault

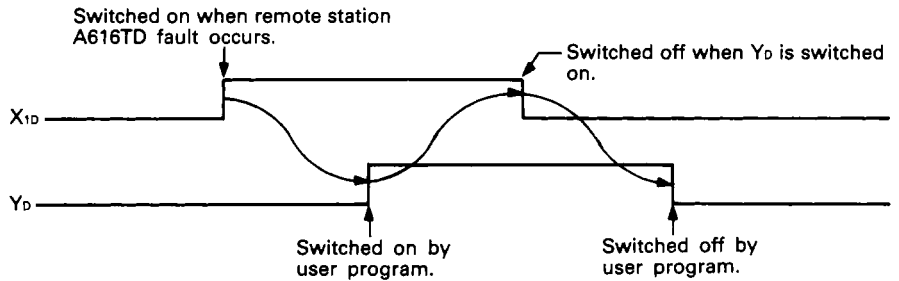

## **RFRP** instruction is executed

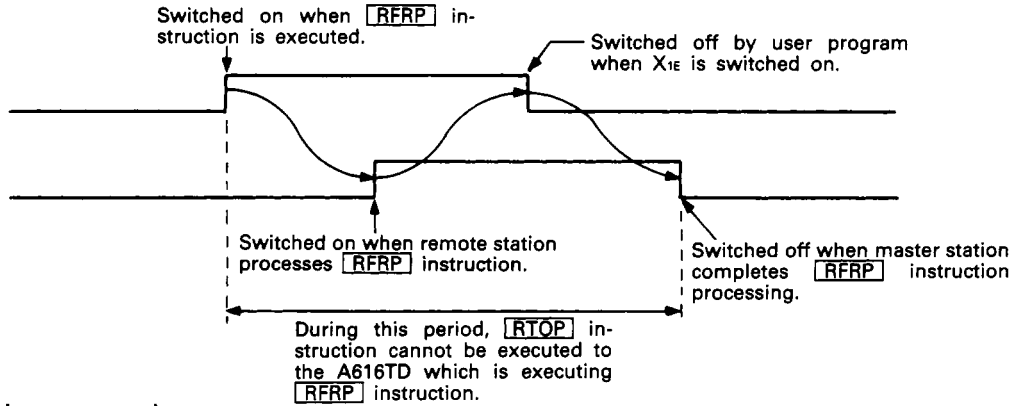

## **RTOP** instruction is executed

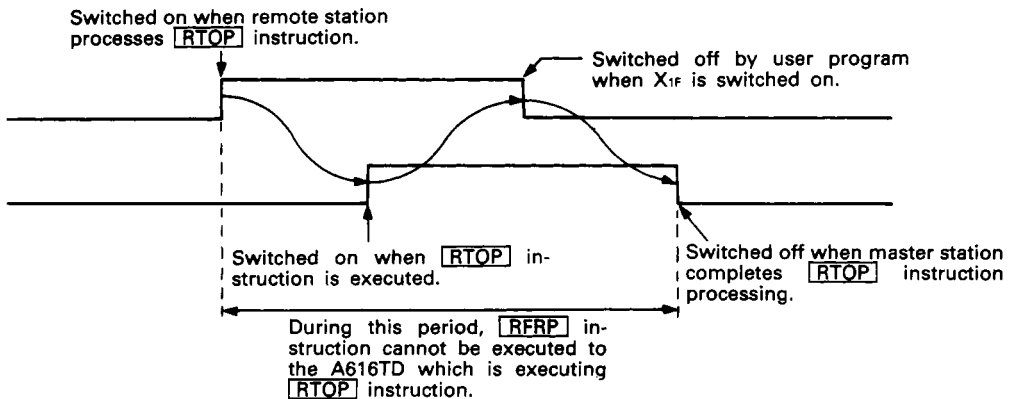

## 5. PROGRAMMING

### 5.13.2 Basic programs for read and write

#### (1) Read from remote I/O station A616TD

##### Format

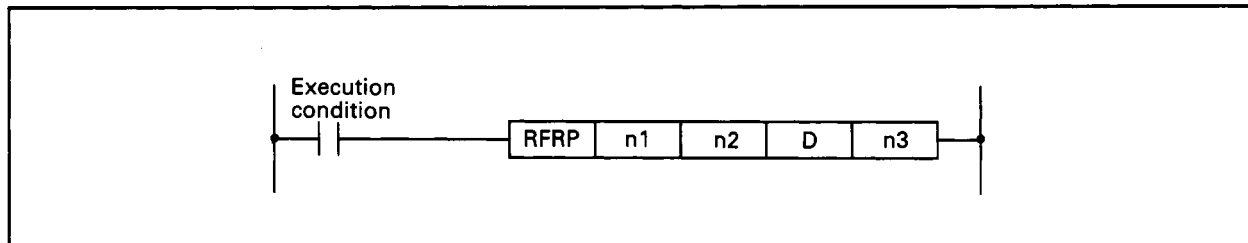

Symbol	Description	Device Used
n1	I/O number assigned to A616TD by master station	K, H
n2	Head address of A616TD buffer memory which stores data	K, H
D	Head number of link register which will store read data	W
n3	Number of words of data read (1 to 16)	K, H

Example: To read 1 word to W52 from the buffer memory address 180 (digital output value) of the remote I/O station A616TD assigned to X, Y130 to 14F by the master station.

To execute read only once by switching on the read signal

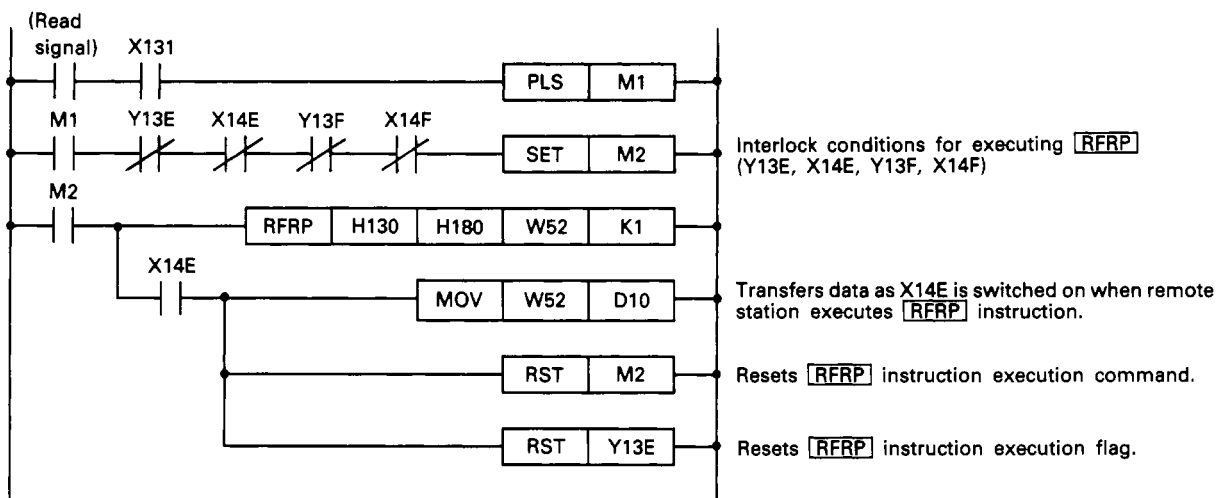

# 5. PROGRAMMING

To continuously execute read while the read signal is on  
(Executed per two scans)

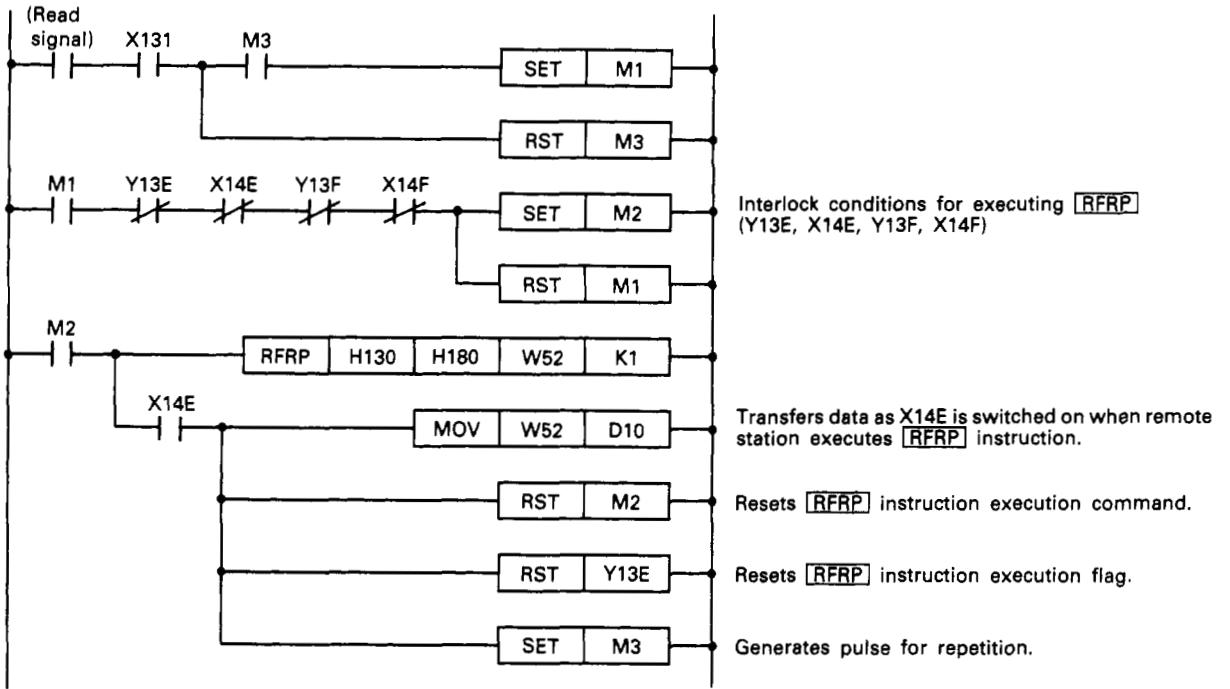

**POINT**

The number of digits of the head I/O signal, n1, is three for the **RFRP** and **RTOP** instructions.

## 5. PROGRAMMING

(2) Write to remote I/O station A616TD

Format

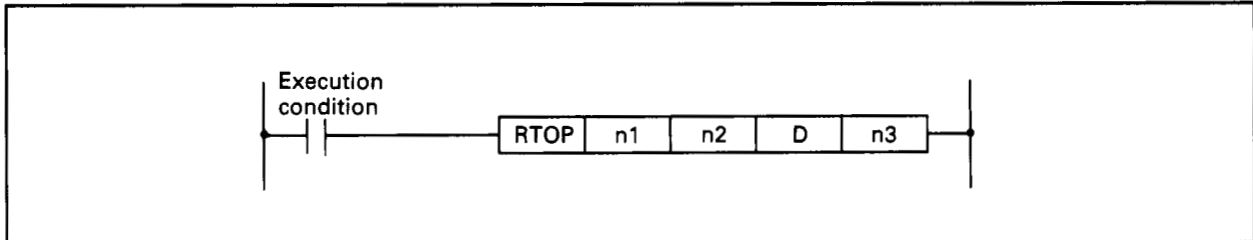

Symbol	Description	Device Used
n1	I/O number assigned to A616TD by master station	K, H
n2	Head address of A616TD buffer memory which will store written data	K, H
D	Head number of link register which stores data	W
n3	Number of words of data written (1 to 16)	K, H

Example: To write 1 word from W50 to the buffer memory address 18 (set data setting request) of the remote I/O station A616TD assigned to X, Y130 to 14F by the master station.

To execute write only once by switching on the write signal

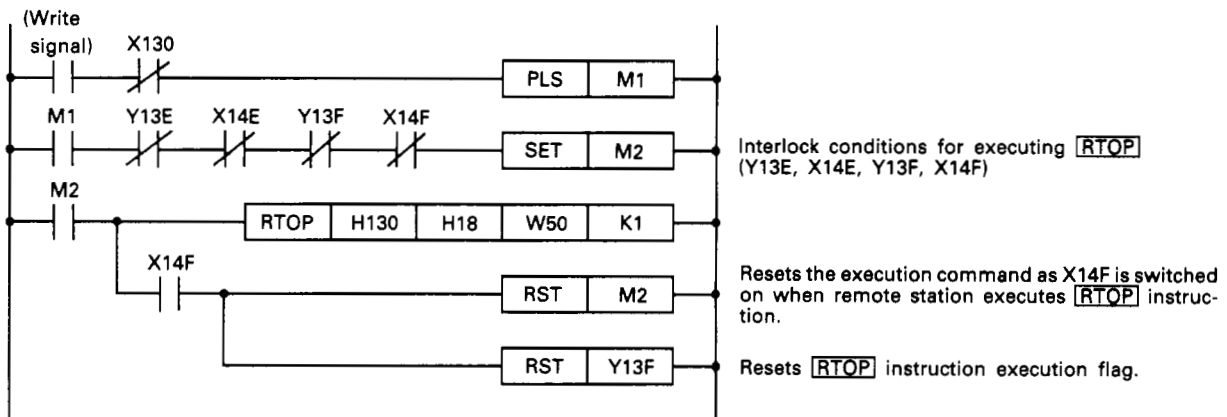

### POINT

The number of digits of the head I/O signal, n1, is three for the **RFRP** and **RTOP** instructions.

## 5. PROGRAMMING

(3) Reading continuously from remote I/O station A616TD and writing set data

Example: To disable the A616TD INPUT 2 from A/D conversion during continuous read of 1 word to W52 from the buffer memory address 180 (digital output value) of the remote I/O station A616 assigned to X, Y130-14F by the master station, and after defining disable, to read data from the buffer memory address 180 again.

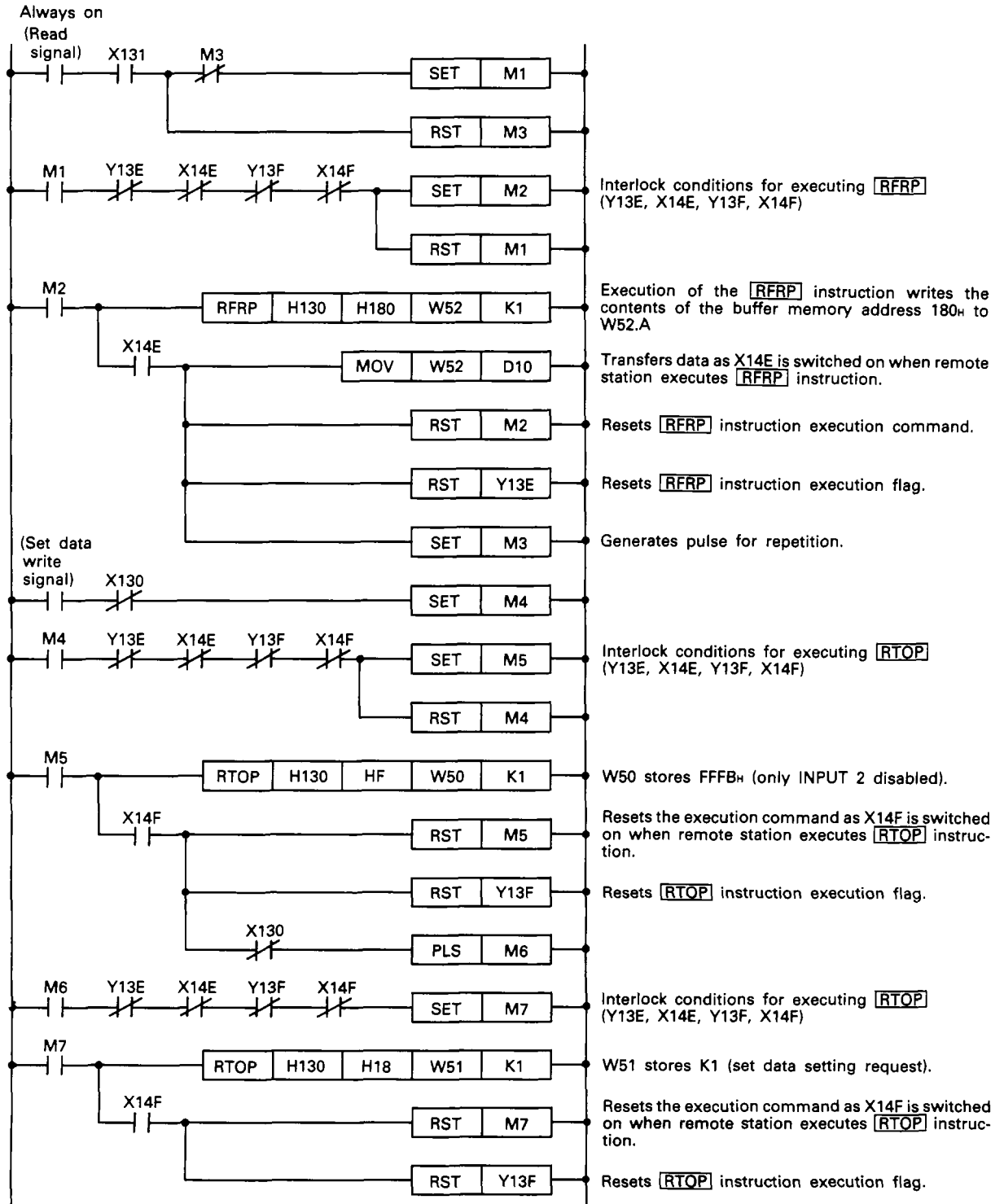

# MEMO

A series of horizontal dotted lines for writing.



# 6. ANALOG/DIGITAL CONVERSION FUNCTIONS

## 6. ANALOG/DIGITAL CONVERSION FUNCTIONS

The setting procedure and programming method are described below for the analog/digital conversion (A/D conversion) of analog signals input directly to the A616TD INPUT channel or to a MX CH. channel of an A60MX or A60MXR module connected to an A616TD.

Refer to Chapters 4 and 5 for details of the setting procedure and programming method for temperature/digital conversion.

### 6.1 Pre-Operation Settings and Procedures

#### 6.1.1 Pre-operation settings and procedures

Make the following settings before carrying out analog signal input into an A616TD module directly, or to an A60MX or A60MXR module connected to an A616TD module.

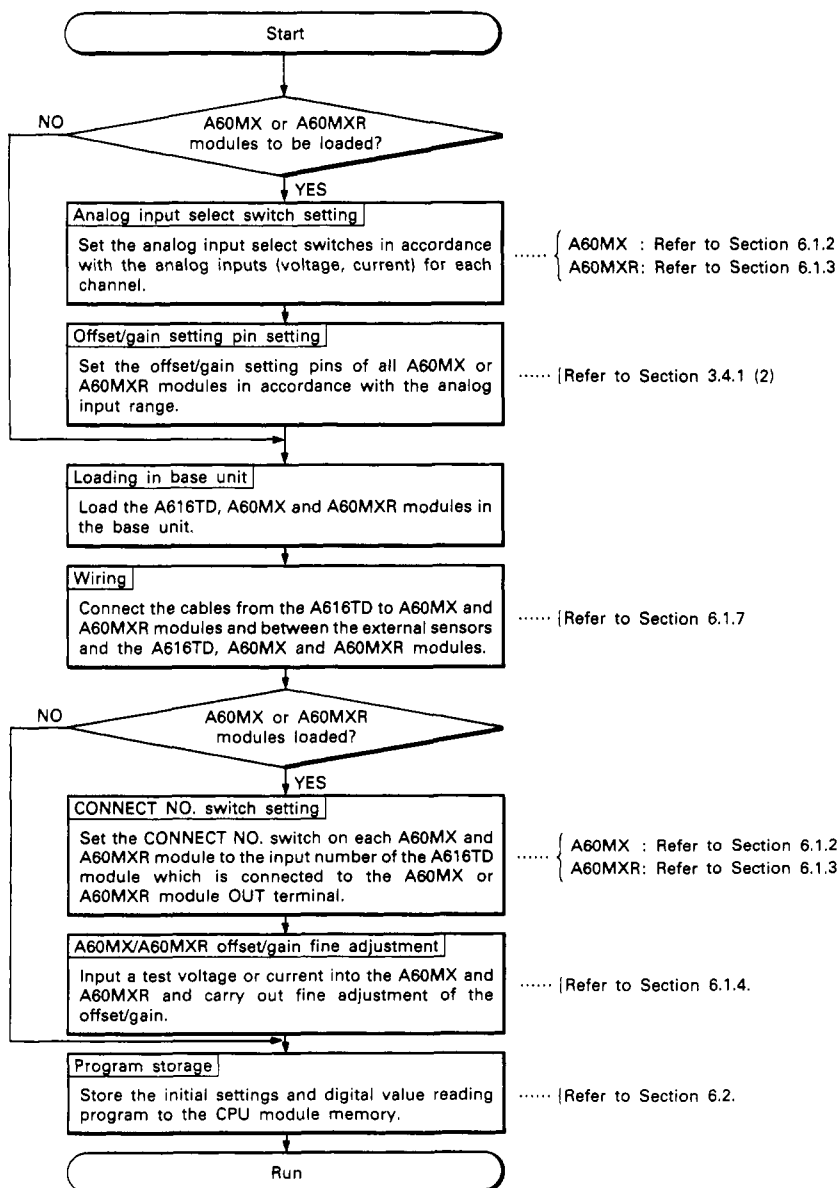



## 6. ANALOG/DIGITAL CONVERSION FUNCTIONS

### 6.1.2 Description and settings of A60MX parts

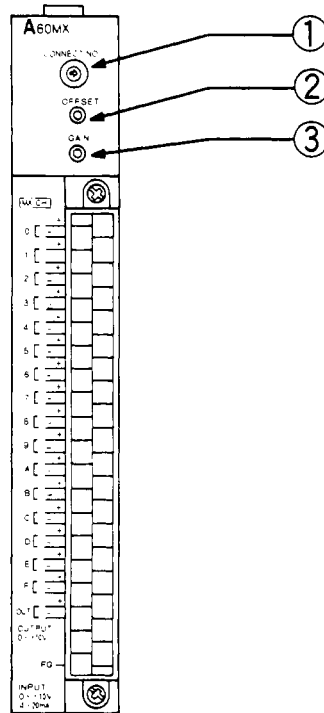
Description and settings of A60MX parts.



No.	Name and Appearance	Description
①	<p>CONNECT NO. switch</p> <p>CONNECT NO.</p> 	<p>Used to specify to which input of the A616TD the A60MX output is connected.</p> <p>Setting range: 0 to 7</p>
②	<p>Offset control</p> <p>OFFSET</p> 	<p>Used to make microadjustments of the offset value, which is selected by the setting pins S17 and S18 in the module.</p> <p>For further details, refer to Section 6.1.4, Offset/Gain Settings.</p>
③	<p>Gain control</p> <p>GAIN</p> 	<p>Used to make microadjustments of the gain value, which is selected by the setting pins S17 and S18 in the module.</p> <p>For further details, refer to Section 6.1.4, Offset/Gain Settings.</p>

# 6. ANALOG/DIGITAL CONVERSION FUNCTIONS

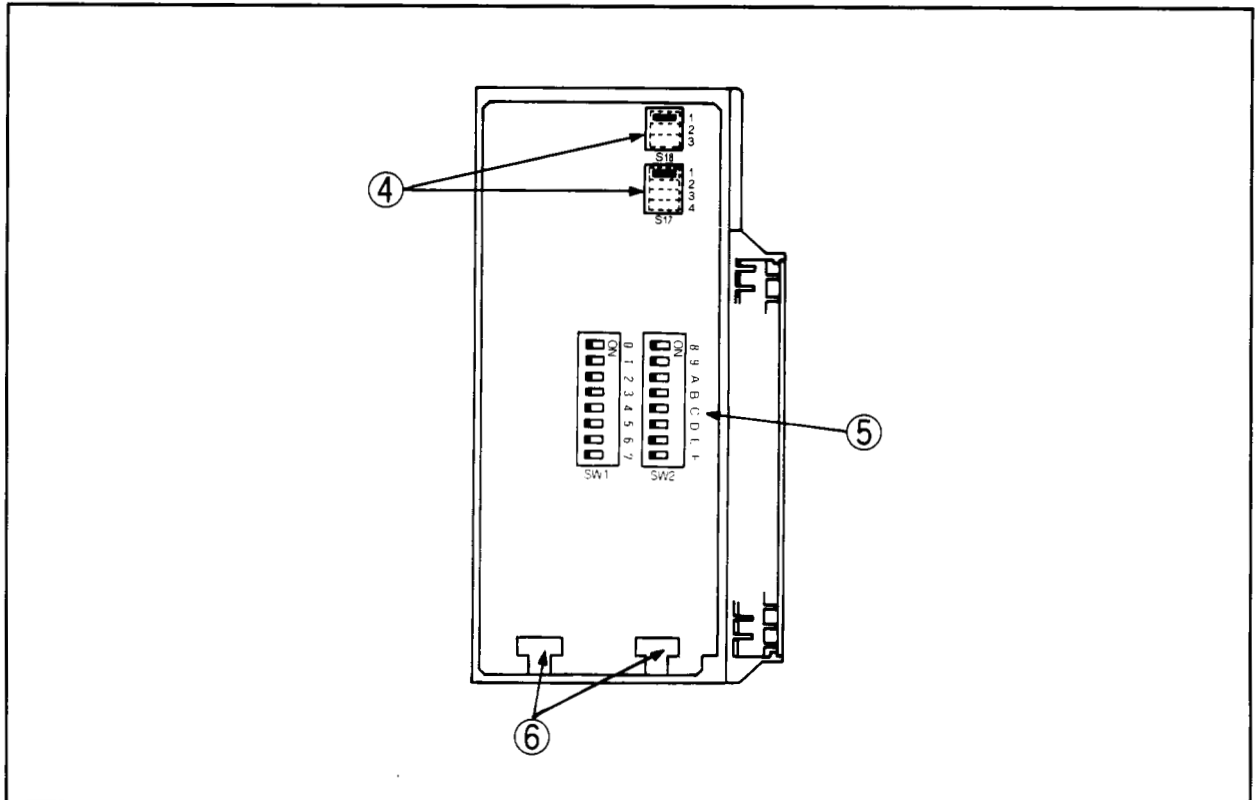

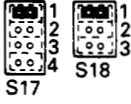
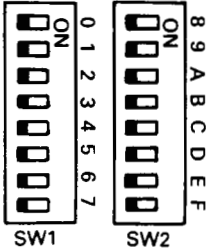



No.	Name and Appearance	Description
④	<p data-bbox="201 1004 472 1042">Offset/gain setting pins</p> 	<p data-bbox="625 1004 1383 1094">Set the S17 and S18 offset/gain setting pins in accordance with the analog input voltage/current range and the setting of the A616TD offset/gain setting pins.</p> <p data-bbox="625 1094 1383 1145">For further details, refer to Section 3.4.1 (2) , A60MX and A60MXR Input Characteristics.</p> <p data-bbox="625 1145 1383 1176">Set to "1" on shipment from factory.</p>
⑤	<p data-bbox="201 1311 534 1348">Analog input select switches</p> 	<p data-bbox="625 1311 1383 1373">Used to select the type of analog input (voltage or current) of each channel (CH. 0 to CH. F).</p> <p data-bbox="625 1373 1383 1404">OFF: Voltage input setting</p> <p data-bbox="625 1404 1383 1435">ON : Current input setting</p> <p data-bbox="625 1456 1383 1487">Set to OFF on shipment from factory.</p>
⑥	<p data-bbox="201 1748 515 1786">Extension cable connectors</p>	<p data-bbox="625 1748 1383 1810">Connection cable to other A60MX and/or A60MXR modules inserted next to the A60MX to increase the number of channels.</p> <p data-bbox="625 1810 1383 1842">The extension cable may be connected to either connector.</p>

## 6. ANALOG/DIGITAL CONVERSION FUNCTIONS

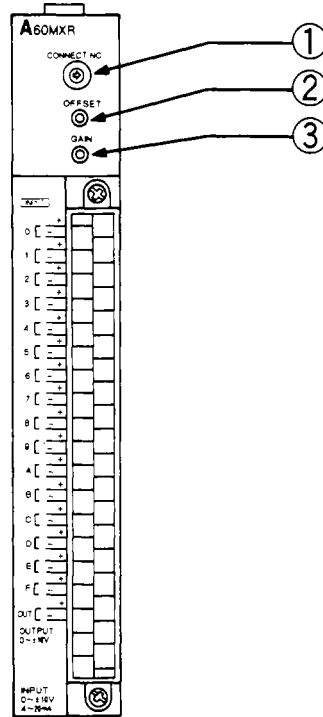
### 6.1.3 Description and settings of A60MXR parts

Description and settings of A60MXR parts.



No.	Name and Appearance	Description
①	<p>CONNECT NO. switch</p> <p>CONNECT NO.</p> 	<p>Used to specify to which input of the A616TD the A60MXR output is connected.</p> <p>Setting range: 0 to 7</p>
②	<p>Offset control</p> <p>OFFSET</p> 	<p>Used to make microadjustments of the offset value, which is selected by the setting pins S17 and S18 in the module.</p> <p>For further details, refer to Section 6.1.4, Offset/Gain Settings.</p>
③	<p>Gain control</p> <p>GAIN</p> 	<p>Used to make microadjustments of the gain value, which is selected by the setting pins S17 and S18 in the module.</p> <p>For further details, refer to Section 6.1.4, Offset/Gain Settings.</p>

# 6. ANALOG/DIGITAL CONVERSION FUNCTIONS

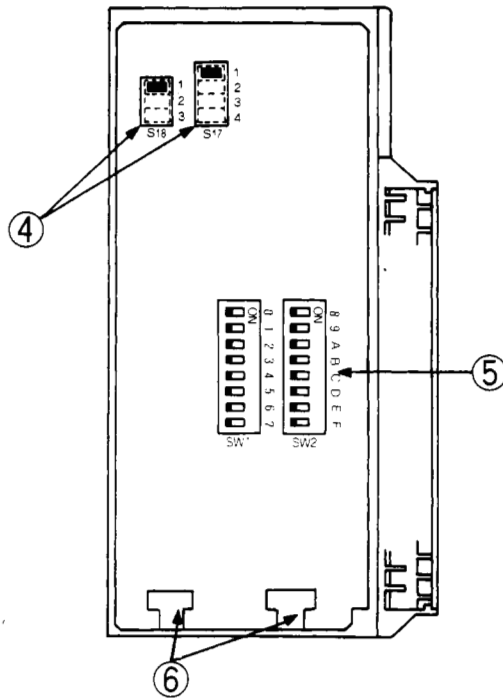

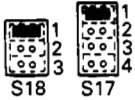
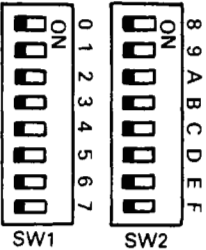
No.	Name and Appearance	Description
④	<p data-bbox="201 1011 465 1042">Offset/gain setting pins</p> 	<p data-bbox="624 1011 1370 1094">Set the S17 and S18 offset/gain setting pins in accordance with the analog input voltage/current range and the setting of the A616TD offset/gain setting pins.</p> <p data-bbox="624 1094 1370 1145">For further details, refer to Section 3.4.1 (2) , A60MX and A60MXR Input Characteristics.</p> <p data-bbox="624 1145 1048 1176">Set to "1" on shipment from factory.</p>
⑤	<p data-bbox="201 1321 525 1353">Analog input select switches</p> 	<p data-bbox="624 1321 1370 1373">Used to select the type of analog input (voltage or current) of each channel (CH 0 to F).</p> <p data-bbox="645 1373 946 1404">OFF: Voltage input setting</p> <p data-bbox="645 1404 946 1435">ON : Current input setting</p> <p data-bbox="624 1456 1053 1487">Set to OFF on shipment from factory.</p>
⑥	<p data-bbox="201 1757 508 1788">Extension cable connectors</p>	<p data-bbox="624 1757 1370 1808">Connection cable to other A60MX and/or A60MXR modules inserted next to the A60MXR to increase the number of channels.</p> <p data-bbox="624 1808 1300 1839">The extension cable may be connected to either connector.</p>

## 6. ANALOG/DIGITAL CONVERSION FUNCTIONS

### 6.1.4 Offset/Gain microadjustment

The relationship between analog input values and output values is determined by setting the offset/gain setting pins to select one of the predetermined I/O characteristics to suit the analog input range. The I/O characteristics set with the offset/gain setting pins differ slightly between modules depending on the ambient temperature and variations in A/D converter characteristics, etc. The modules are microadjusted in the factory to eliminate these slight differences.

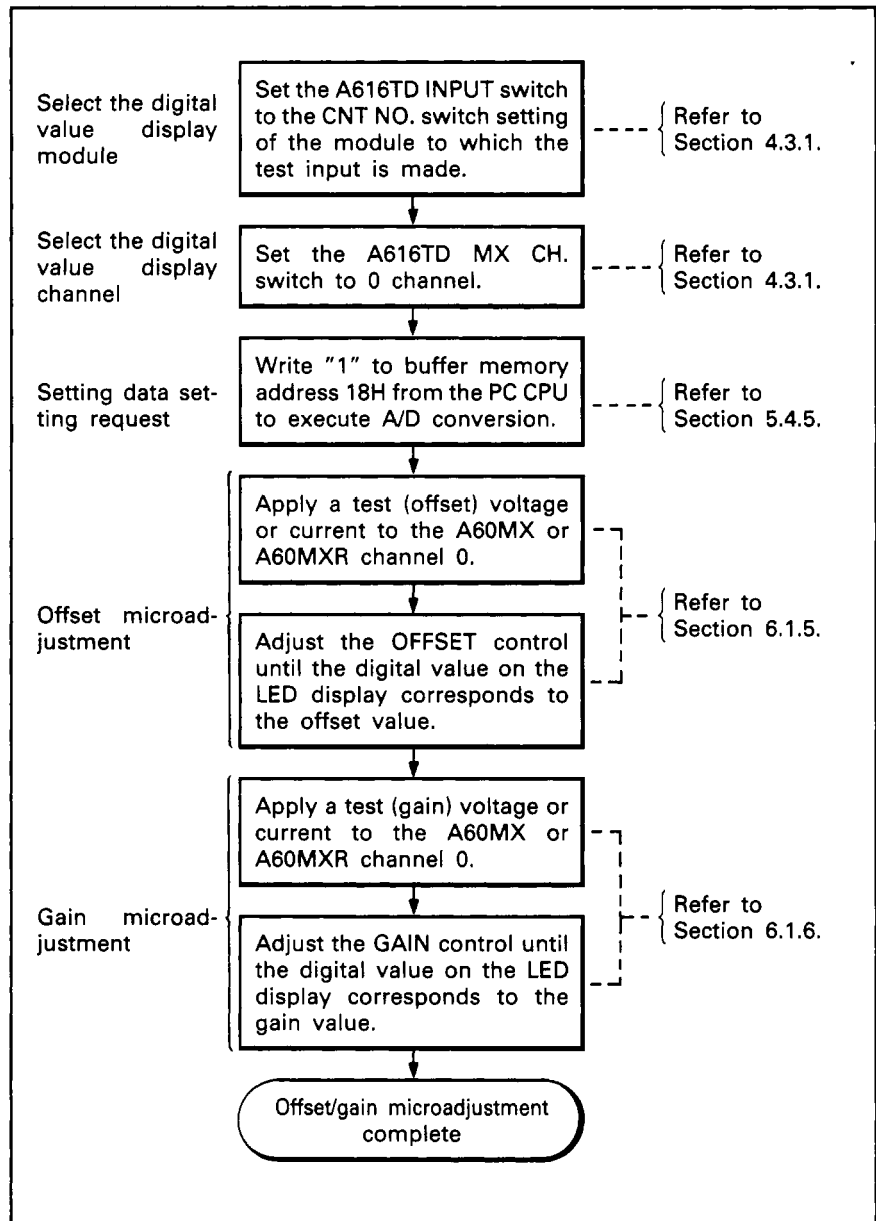

Fig. 6.1 Offset/Gain Microadjustment Procedure

## 6. ANALOG/DIGITAL CONVERSION FUNCTIONS

### 6.1.5 Offset microadjustment

Carry out the microadjustment using the OFFSET control on the front of the module.

Apply a test voltage or current which corresponds to the offset value of the I/O characteristic which is selected with the analog input select switches and the offset/gain setting pins.

Adjust the OFFSET control until the digital value displayed on the LED's on the front of the module matches the digital value corresponding to the analog test voltage or current being input.

A60MX, A60MXR		A60MX/A60MXR Analog Input Select Switch Position			
Offset/gain setting pin setting		V		I	
S17	S18	Test voltage (V)	Digital value	Test current (mA)	Digital value
1	1	0	0	0	0
2	1	0	0	0	0
3	2	1	0	4	0
4	3	0	2000	0	2000
1	3	0	2000	0	2000

Table 6.1 A60MX and A60MXR Test Voltages, Currents and Digital Values

#### Example

Set the A60MX or A60MXR offset/gain setting pins S17 to "2" and S18 to "1" and set the A60MX or A60MXR analog input select switch to the "V" position.

Apply a test voltage of 0V to the A60MX or A60MXR channel 0 and adjust the OFFSET control until the LED display indicates the value "0".

### 6.1.6 Gain microadjustment

Carry out the microadjustment using the GAIN control on the front of the module.

Apply a test voltage or current which corresponds to the gain value of the I/O characteristic which is selected with the analog input select switches and the offset/gain setting pins.

Adjust the GAIN control until the digital value displayed on the LED's on the front of the module matches the digital value corresponding to the analog test voltage or current being input.

A60MX, A60MXR		A60MX/A60MXR Analog Input Select Switch Position			
Offset/gain setting pin setting		V		I	
S17	S18	Test voltage (V)	Digital value	Test current (mA)	Digital value
1	1	10	4000	20	2000
2	1	5	4000	20	4000
3	2	5	4000	20	4000
4	3	10	4000	20	3000
1	3	5	4000	20	4000

Table 6.2 A60MX and A60MXR Test Voltages, Currents and Digital Values

#### Example

Set the A60MX or A60MXR offset/gain setting pins S17 to "1" and S18 to "1" and set the A60MX or A60MXR analog input select switch to the "V" position.

Apply a test voltage of 10V to the A60MX or A60MXR channel 0 and adjust the GAIN control until the LED display indicates the value "4000".

## 6. ANALOG/DIGITAL CONVERSION FUNCTIONS

### 6.1.7 Wiring instructions

- (1) Wiring example for a stand-alone A616TD module  
An example of a voltage input for the A616TD is shown below.

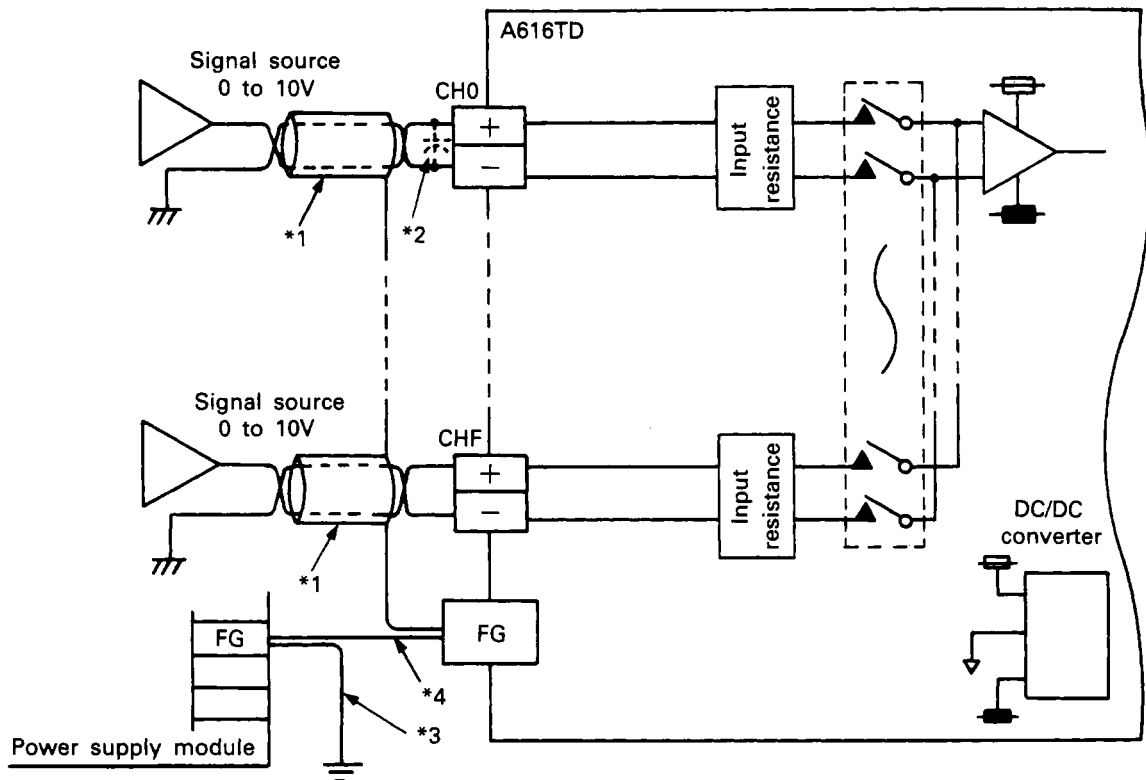

- \*1 Use only two-core twisted shield wire.
- \*2 If noise or ripple is generated in the external wiring, connect an approx.  $0.1$  to  $0.47 \mu\text{F}$   $25\text{WV}$  capacitor between the  $+$  and  $-$  terminals.
- \*3 The FG terminals of the power supply module must be grounded.
- \*4 Always connect the A616TD FG terminal to the power supply module FG terminal.



## 6. ANALOG/DIGITAL CONVERSION FUNCTIONS

- (2) Wiring example for an A616TD connected to an A60MX or A60MXR module

Examples are shown below for voltage and current inputs to the A616TD connected to an A60MX or A60MXR module.

(a) Voltage input

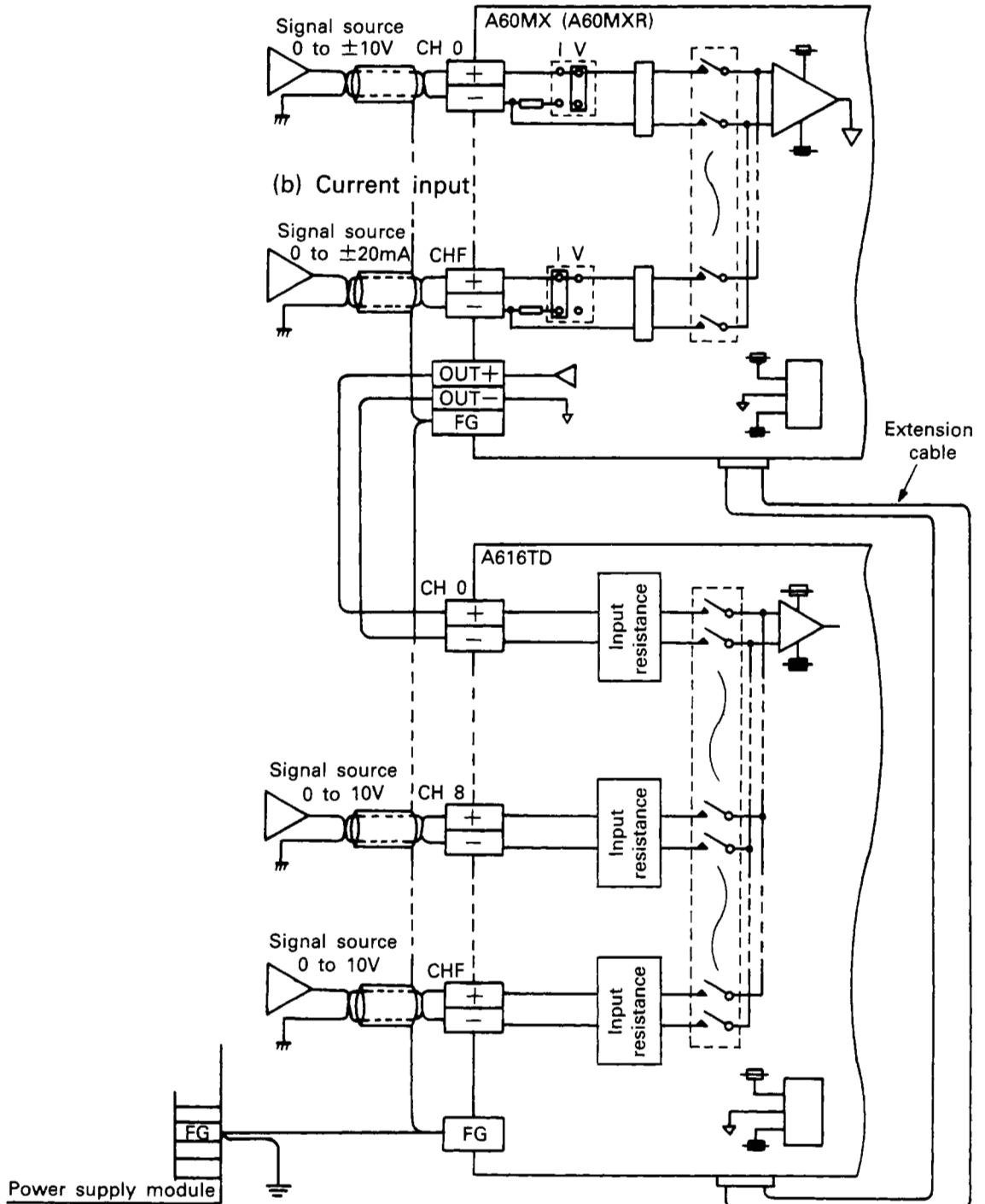

# 6. ANALOG/DIGITAL CONVERSION FUNCTIONS

## 6.2 Programming Procedure

An A616TD analog/digital conversion program is written according to the following procedure:

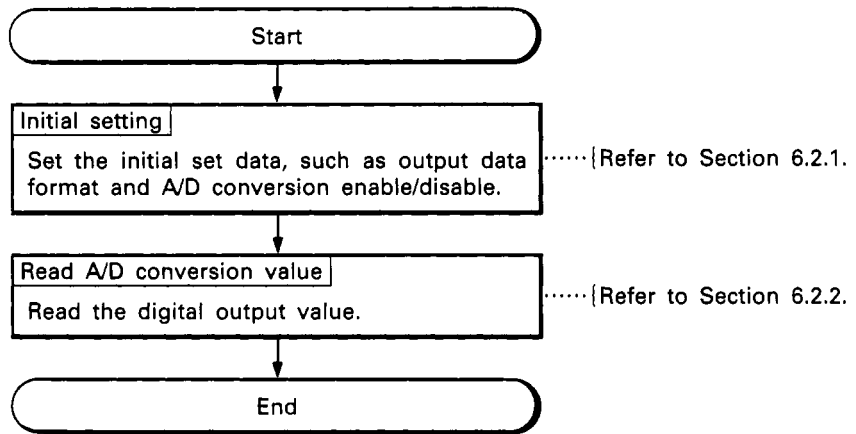

### 6.2.1 Initial setting

The initial setting program shown below must be included before any program to read digital output values.

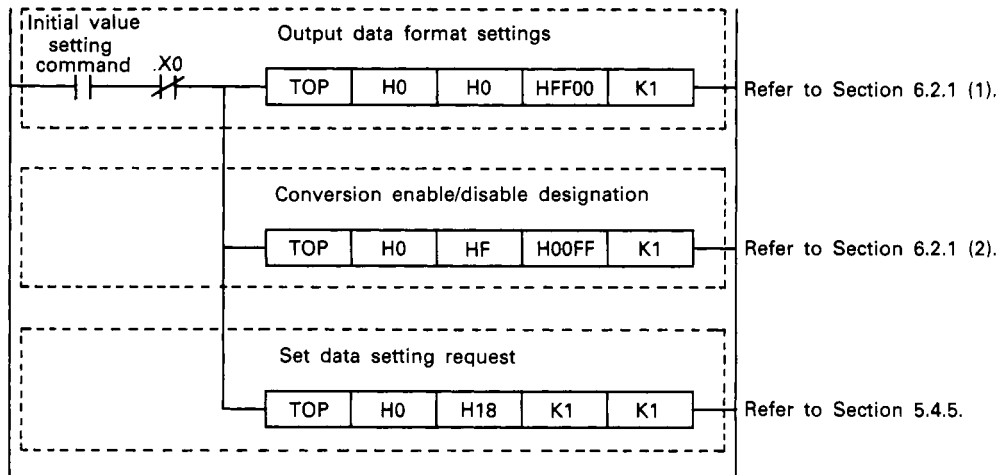

In cases where a combination of temperature/digital conversion and analog/digital conversion is to be carried out, write both the initial data for the temperature/digital conversion and that for the analog/digital conversion to the buffer memory and then finally execute the set data setting request once only.

(1) Setting the data format Set the A/D conversion output data format (whether the output values are to be in the form  $-48$  to  $4057$  or  $-2048$  to  $2047$ ) for each A616TD INPUT channel and write the data to the buffer memory address "0."

(a) Default values are written to address  $0_H$  to set the " $-48$  to  $4047$ " data format for all INPUT channels when the power supply is turned on or the PC CPU reset.

## 6. ANALOG/DIGITAL CONVERSION FUNCTIONS

(b) The 16-bit configuration of the memory area is shown below.

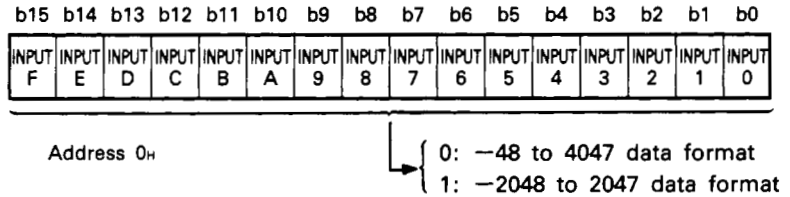

(c) The data format is fixed at the -48 to 4047 data format for INPUT channels to which a A616TD module is attached. Any other set data for these channels is ignored.

**POINT**

**No setting is required if the -48 to 4047 data format is to be used for all INPUT channels.**

(2) Specifying A/D conversion enable/disable  
 Write "0" or "1", respectively, to the buffer memory addresses F<sub>H</sub> to 17<sub>H</sub> to disable or enable A/D conversion for each A616TD, A60MX and A60MXR channel.

Refer to Section 5.4.2 if the modules are to connected to A60MXT to carry out both temperature/digital conversion and analog/digital conversion.

(a) Default values are written when the power supply is turned on or the PC CPU reset to enable conversion for all channels.

(b) The 16-bit configuration of the memory area is shown below.

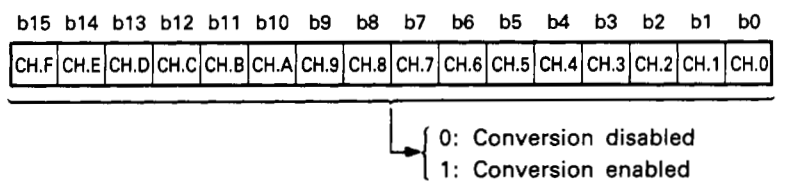

(c) The setting area of buffer memory addresses F<sub>H</sub> to 17<sub>H</sub> is configured as follows.

Address	
F <sub>H</sub>	A616TD INPUT 0 to F Channel conversion enable/disable setting area
10 <sub>H</sub>	CNT. No. 0 MX CX. 0 to F Channel conversion enable/disable setting area
11 <sub>H</sub>	CNT. No. 1 MX CX. 0 to F Channel conversion enable/disable setting area
12 <sub>H</sub>	CNT. No. 2 MX CX. 0 to F Channel conversion enable/disable setting area
13 <sub>H</sub>	CNT. No. 3 MX CX. 0 to F Channel conversion enable/disable setting area
14 <sub>H</sub>	CNT. No. 4 MX CX. 0 to F Channel conversion enable/disable setting area
15 <sub>H</sub>	CNT. No. 5 MX CX. 0 to F Channel conversion enable/disable setting area
16 <sub>H</sub>	CNT. No. 6 MX CX. 0 to F Channel conversion enable/disable setting area
17 <sub>H</sub>	CNT. No. 7 MX CX. 0 to F Channel conversion enable/disable setting area

**POINT**

(1) The sampling period decreases the more the number of channels for which A/D conversion is enabled.

(2) "0" (conversion disable) is automatically written to the area for channels which are not connected to A60MX.

## 6. ANALOG/DIGITAL CONVERSION FUNCTIONS

### 6.2.2 Reading the digital output values

The analog values input to the A616TD, A60MX and A60MXR channels are sampled and A/D conversion carried out for each channel. The digital output values are stored for each channel in the buffer memory.

The digital output value can be read by the PC CPU for any channel by specifying the buffer memory address.

- (1) Two types of area are used to store the digital output values: the A616TD INPUT channel storage area and A60MX and A60MXR MX CH. channel storage area.
- (2) The 16-bit configuration of both types of memory area is shown below.

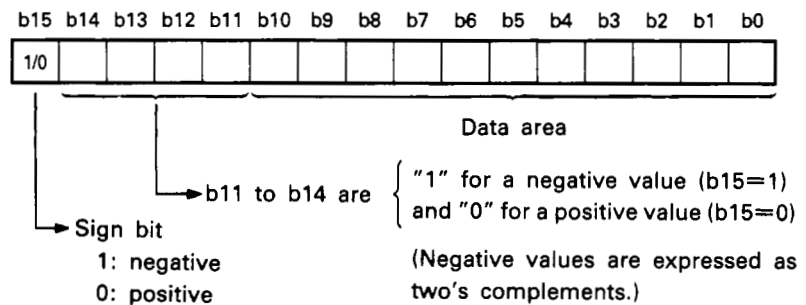

- (3) The data stored in the INPUT channel storage area differs depending on whether the channel is connected to an external sensor or to an A60MX or A60MXR module.
  - (a) If an external sensor is connected  
 The digital value converted from the analog value input from the external sensor is stored in the memory area.
  - (b) If an A60MX or A60MXR module is connected  
 The digital value converted from the analog value input from the external sensor connected to the MX CH. 0 channel of the A60MX or A60MXR is stored in the memory area.

Address	
70 <sub>H</sub>	INPUT 0 digital output value
71 <sub>H</sub>	INPUT 1 digital output value
72 <sub>H</sub>	INPUT 2 digital output value
73 <sub>H</sub>	INPUT 3 digital output value
74 <sub>H</sub>	INPUT 4 digital output value
75 <sub>H</sub>	INPUT 5 digital output value
76 <sub>H</sub>	INPUT 6 digital output value
77 <sub>H</sub>	INPUT 7 digital output value
78 <sub>H</sub>	INPUT 8 digital output value
79 <sub>H</sub>	INPUT 9 digital output value
7A <sub>H</sub>	INPUT A digital output value
7B <sub>H</sub>	INPUT B digital output value
7C <sub>H</sub>	INPUT C digital output value
7D <sub>H</sub>	INPUT D digital output value
7E <sub>H</sub>	INPUT E digital output value
7F <sub>H</sub>	INPUT F digital output value

The relationship between the area addresses and channel numbers is as follows:



# 6. ANALOG/DIGITAL CONVERSION FUNCTIONS

## Example

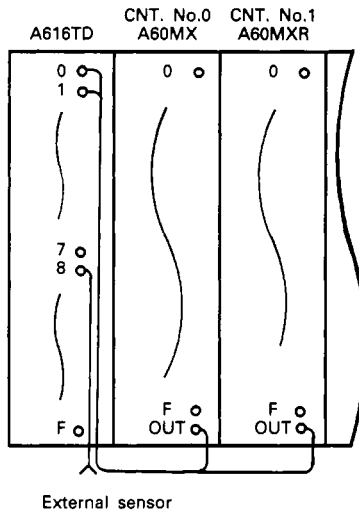

A60MX and A60MXR modules are connected to channels 0 and 1 of the A616TD and an external sensor is connected to channel 8.

The data is stored in the addresses as follows:

- Address 70<sub>H</sub>: digital value from channel 0 of the A60MX connected to CNT. NO. 0.
- Address 71<sub>H</sub>: digital value from channel 0 of the A60MXR connected to CNT. NO. 1.
- Address 78<sub>H</sub>: digital value A/D converted from the analog value received from the external sensor.

(4) Digital values A/D converted from the analog values received from external sensors connected to the A60MX and A60MXR channels are stored in the MX CH. channel storage area for each channel.

Address

180 <sub>H</sub>	CNT. No. 0	MX CH. 0	Digital output value
181 <sub>H</sub>		MX CH. 1	Digital output value
182 <sub>H</sub>		MX CH. 2	Digital output value
to		⋮	
18F <sub>H</sub>		MX CH. F	Digital output value
190 <sub>H</sub>	CNT. No. 1	MX CH. 0	Digital output value
191 <sub>H</sub>		MX CH. 1	Digital output value
192 <sub>H</sub>		MX CH. 2	Digital output value
to		⋮	
19F <sub>H</sub>		MX CH. F	Digital output value
to		⋮	
1F0 <sub>H</sub>	CNT. No. 7	MX CH. 0	Digital output value
1F1 <sub>H</sub>		MX CH. 1	Digital output value
1F2 <sub>H</sub>		MX CH. 2	Digital output value
to		⋮	
1FF <sub>H</sub>		MX CH. F	Digital output value

The relationship between the area addresses and channel numbers is as follows:

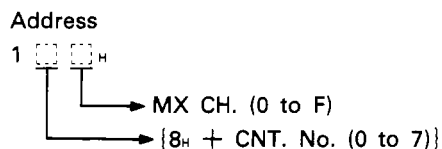

## Example

Address of MX CH. 2 of the CNT NO. 7 A60MXT module:

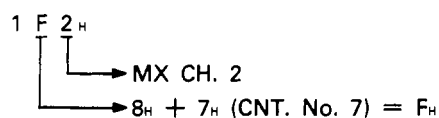

## 6. ANALOG/DIGITAL CONVERSION FUNCTIONS

### 6.2.3 Reading error codes

When the A616TD detects an error, the corresponding error code is stored in buffer memory address 1H as a binary code.

- (1) The stored error code is upgraded each time an error is detected, and the previous value is cleared.
- (2) If an error occurs which results in an error code from 01 to 04, "1" is written to the bit of the buffer memory address 2H which corresponds to the CNT NO. of the faulty module. "1" is written to this address for the appropriate CNT. NO. each time a new error occurs, and this date remains stored until the area is cleared.

- 1) The 16-bit configuration of the memory area is shown below.

b15	b14	b13	b12	b11	b10	b9	b8	b7	b6	b5	b4	b3	b2	b1	b0
CNT.No.	CNT.No.	CNT.No.	CNT.No.	CNT.No.	CNT.No.	CNT.No.	CNT.No.	CNT.No.	CNT.No.	CNT.No.	CNT.No.	CNT.No.	CNT.No.	CNT.No.	CNT.No.
F	E	D	C	B	A	9	8	7	6	5	4	3	2	1	0

0: Normal  
1: Discontinuity or out-of-range

### 6.2.4 Clearing the error code area

- (1) This data remains stored in buffer memory after the causes of the faults have been corrected. Write "0" to the buffer memory addresses 1H and 2H with a sequence program to clear the error data.

# 7. TROUBLESHOOTING

## 7. TROUBLESHOOTING

### 7.1 Error Code List

When an error occurs during use of the A616TD and A60MXT/A60MX/A60MXR, the corresponding error code is indicated on the LED display. The error code is a 16-bit binary and is written to the error code area (address 1<sub>H</sub>).

The table of error codes is shown below.

Type	Error Code	Description	A616TD Operation	"RUN" LED	Error-Check Timing
Card data error	01, 07	(1) Multiplexer module is faulty or incorrectly loaded. (2) Extension cable is faulty or incorrectly connected.	A/D conversion is not executed.	Off	When power turned on
Multiplex module removed	02	Error when one of the following occurs during A/D conversion: (1) Multiplex module removed from base. (2) Extension cable disconnected from module. (3) Positions of discontinuity detection enable /disable setting pins or measurement range setting pins changed after power supply turned on. (4) A60MX, A60MXR or A60MXT CONNECT NO. switch setting changed after power supply turned on.	Processing stops.	Off	Always
CONNECT NO. switch setting error	03	CNT. NO. switch of any multiplex module has been set to a position other than 0 to 7.	Module set to other than 0-7: A/D conversion is not executed. Module set to 0-7: Processing continues.	Off	When power turned on
Measurement range setting error	04	A60MXT measurement range set to value other than 1 to 4.	Modules set to value other than 1 to 4: A/D conversion is not executed. Modules set to value 1 to 4: processing continues.	Flicker	When power turned on
Buffer memory write disable error	10	Data has been written from the PC CPU to the buffer memory read-only area. (Addresses 4 <sub>H</sub> , 70 to 7F <sub>H</sub> , 180 to 27F <sub>H</sub> )	Processing continues.	Flicker	On TO instruction execution
Set data setting request error	12	The value written to the buffer memory set data setting request area is not "1".	At initial setting: A/D conversion is not executed. During A/D conversion: Processing continues under previous conditions.	Flicker	On TO instruction execution
	13	"1" continuously written to the buffer memory set data setting request area with the TO instruction during A/D conversion.			
Buffer memory transfer error	30	A/D conversion data cannot be written to the buffer memory due to an excess of FROM and TO instructions.	Processing continues.	Flicker	Always
Thermocouple type setting error	70	The thermocouple type written to buffer memory has a value other than 1 to 8.	Channels set to value other than 1 to 8: Processing interrupted. Channels set to value 1 to 8: processing continues.	Flicker	On a set data setting request

Table 7.1 Error Code List

#### POINT

- (1) To clear the error code area (address 1<sub>H</sub>), write 0 from the PC CPU. (For details, see Section 5.12 and 6.2.4.)
- (2) The buffer memory data at the occurrence of any error is retained.

# 7. TROUBLESHOOTING

## 7.2 Troubleshooting

Troubleshooting procedures for use of the A616TD are given below. For problems relating to the CPU module, see the corresponding CPU module user's manual.

### 7.2.1 General troubleshooting

Symptom		Remedy
<b>(1) "RUN" LED status</b>		
"RUN" LED flickering	⇒	Section 7.2.2
"RUN" LED off	⇒	Section 7.2.3
<b>(2) CPU module status</b>		
Error code in special register D9008	⇒	Section 7.2.4
CPU module in "SP. UNIT DOWN"	⇒	Section 7.2.5
CPU module in "SP. UNIT ERROR"	⇒	Section 7.2.6
CPU module in "CONTROL-BUS ERR."	⇒	Section 7.2.7
Digital value unreadable from CPU.	⇒	Section 7.2.8
<b>(3) A616TD-CPU module input signal status</b>		
Watch-dog timer (WDT) error signal (X0) is on.	⇒	Section 7.2.9
A/D conversion ready signal (X1) is on.	⇒	Section 7.2.10
Discontinuity error detected signal (X3) or detected temperature output value out-of-range signal (X5) is on.	⇒	Section 7.2.11
Digital output value out-of-range error detected signal (X4) is on.	⇒	Section 7.2.12
Detected temperature value LED display request signal (Y10) is on.	⇒	Section 7.2.13



# 7. TROUBLESHOOTING

Symptom	Remedy
<b>(4) A616TD LED display status</b>	
Rapid fluctuations of digital output value during temperature sensor input.	⇒ Section 7.2.14
Rapid fluctuations of digital output value during analog input.	⇒ Section 7.2.15
Error code indicated on the LED display.	⇒ Section 7.2.16
<b>(5) A616TD A/D conversion status</b>	
No correlation between temperature sensor input value and digital output value.	⇒ Section 7.2.17
No correlation between analog input value and digital output value.	⇒ Section 7.2.18
Constant digital output value deviation from reference value during temperature sensor input.	⇒ Section 7.2.19
Constant digital output value deviation from reference value during analog input.	⇒ Section 7.2.20
Error compensation is abnormal.	⇒ Section 7.2.21

## 7. TROUBLESHOOTING

### 7.2.2 "RUN" LED flickering

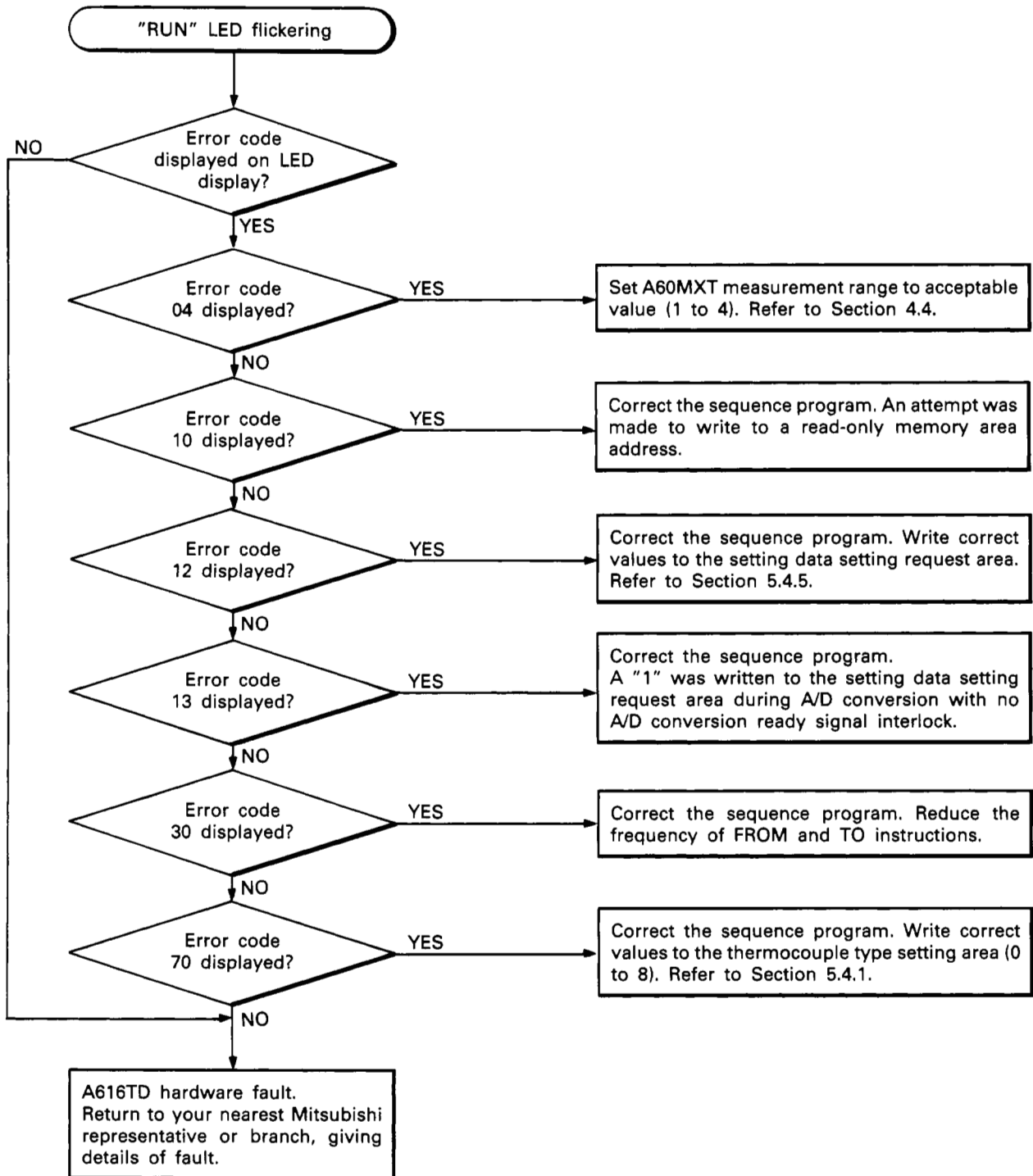

# 7. TROUBLESHOOTING

## 7.2.3 "RUN" LED off

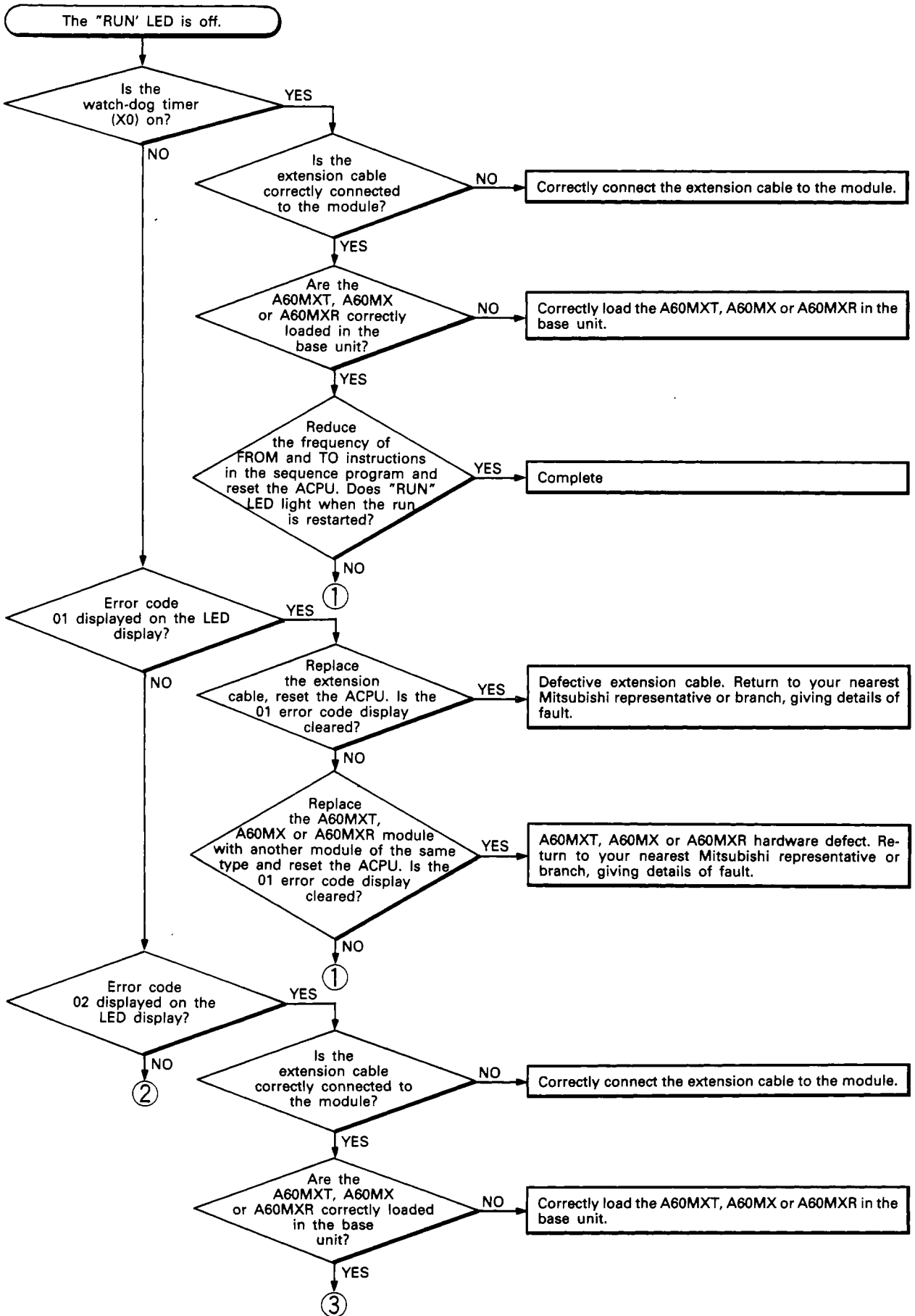

# 7. TROUBLESHOOTING

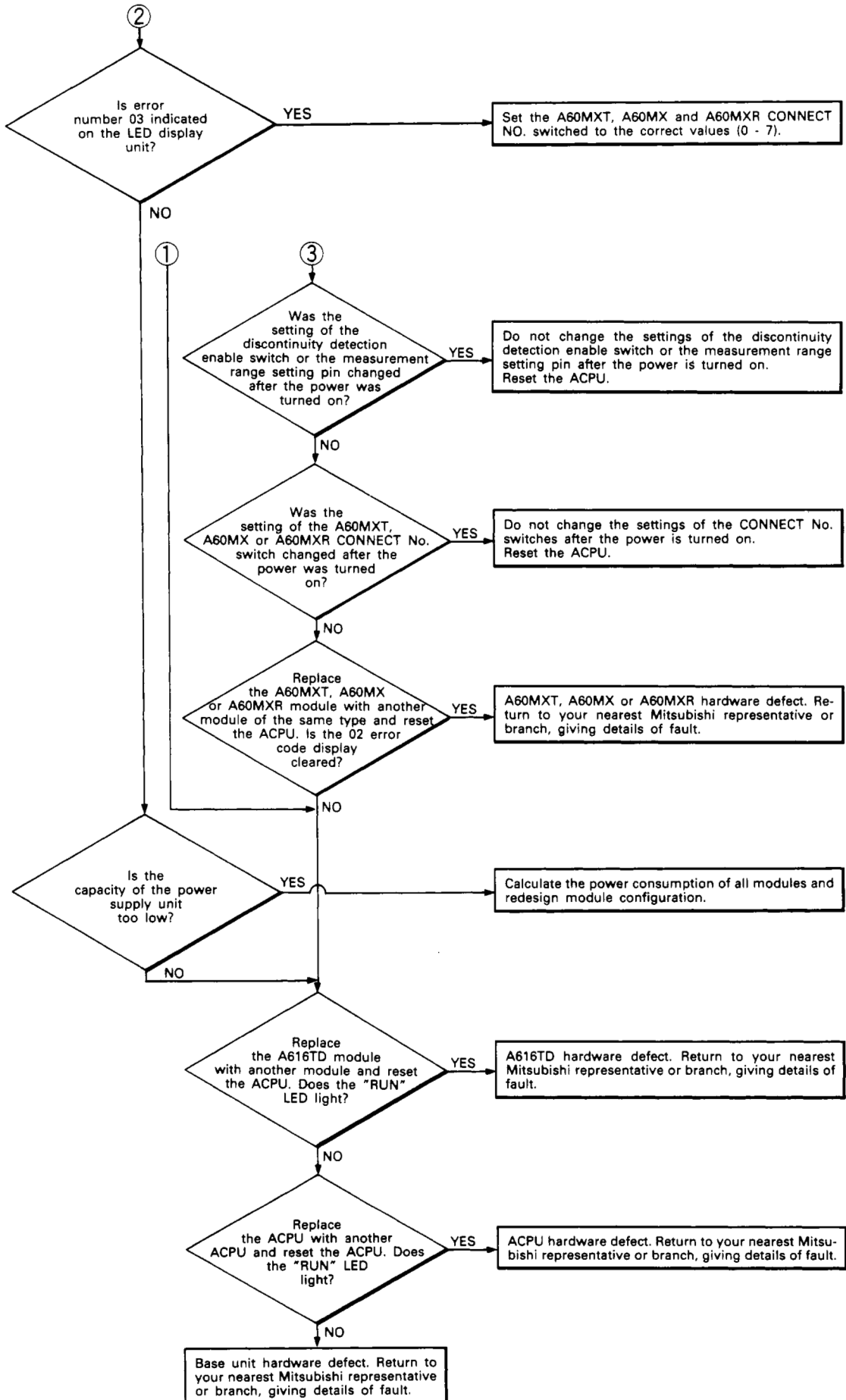

# 7. TROUBLESHOOTING

## 7.2.4 Error code in special register D9008

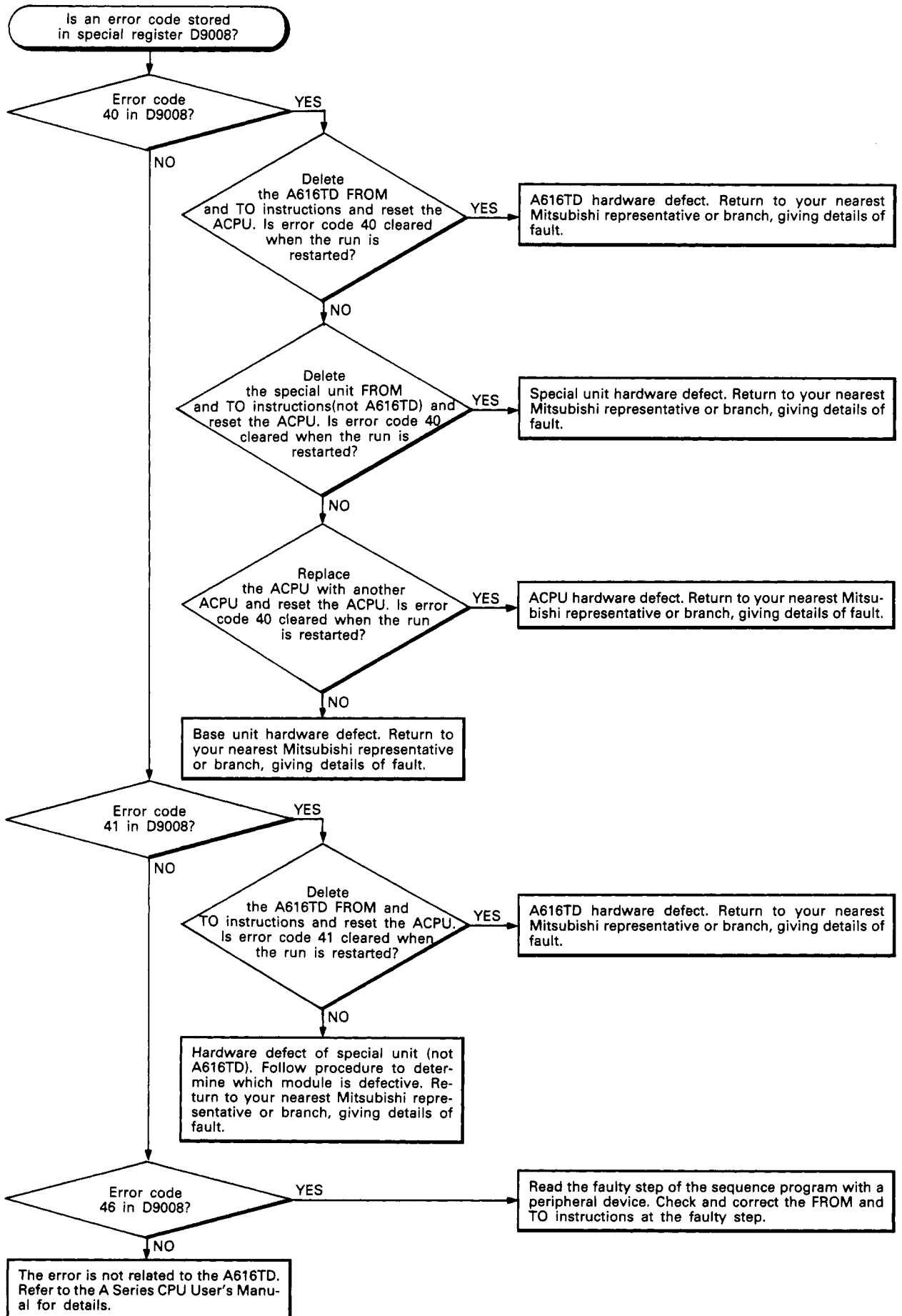

# 7. TROUBLESHOOTING

## 7.2.5 CPU module "SP. UNIT DOWN" error

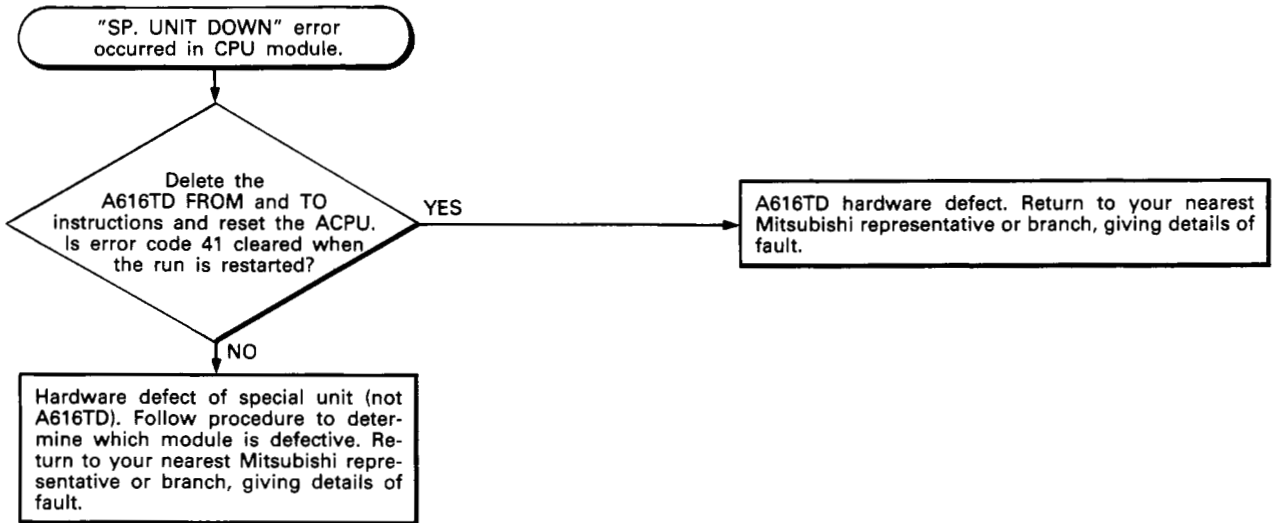

## 7.2.6 CPU module "SP. UNIT ERROR" error

Read the faulty step of the sequence program with a peripheral device. Check and correct the FROM and TO instructions at the faulty step.

## 7.2.7 CPU module "CONTROL-BUS ERROR" error

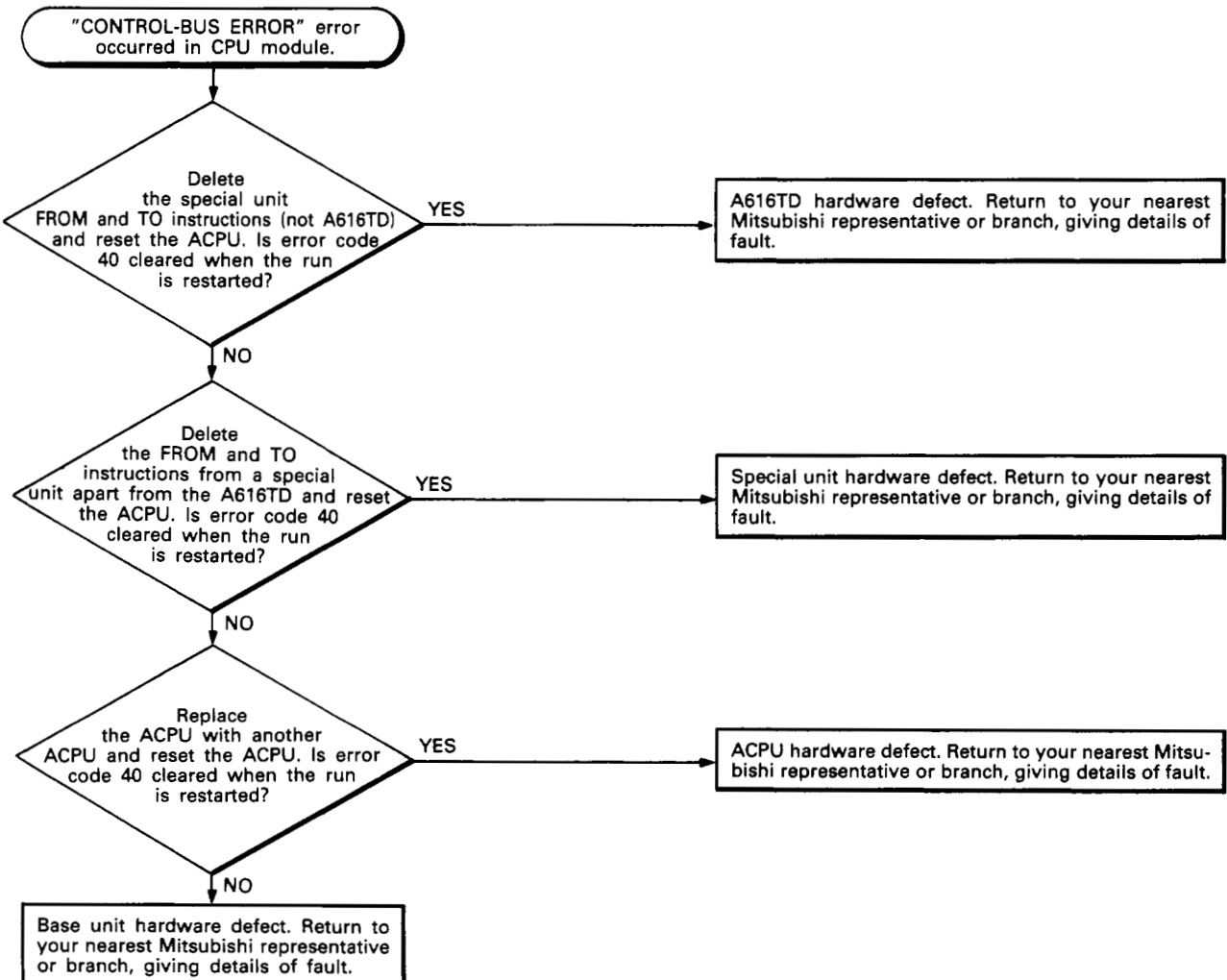

# 7. TROUBLESHOOTING

## 7.2.8 CPU unable to read digital output value

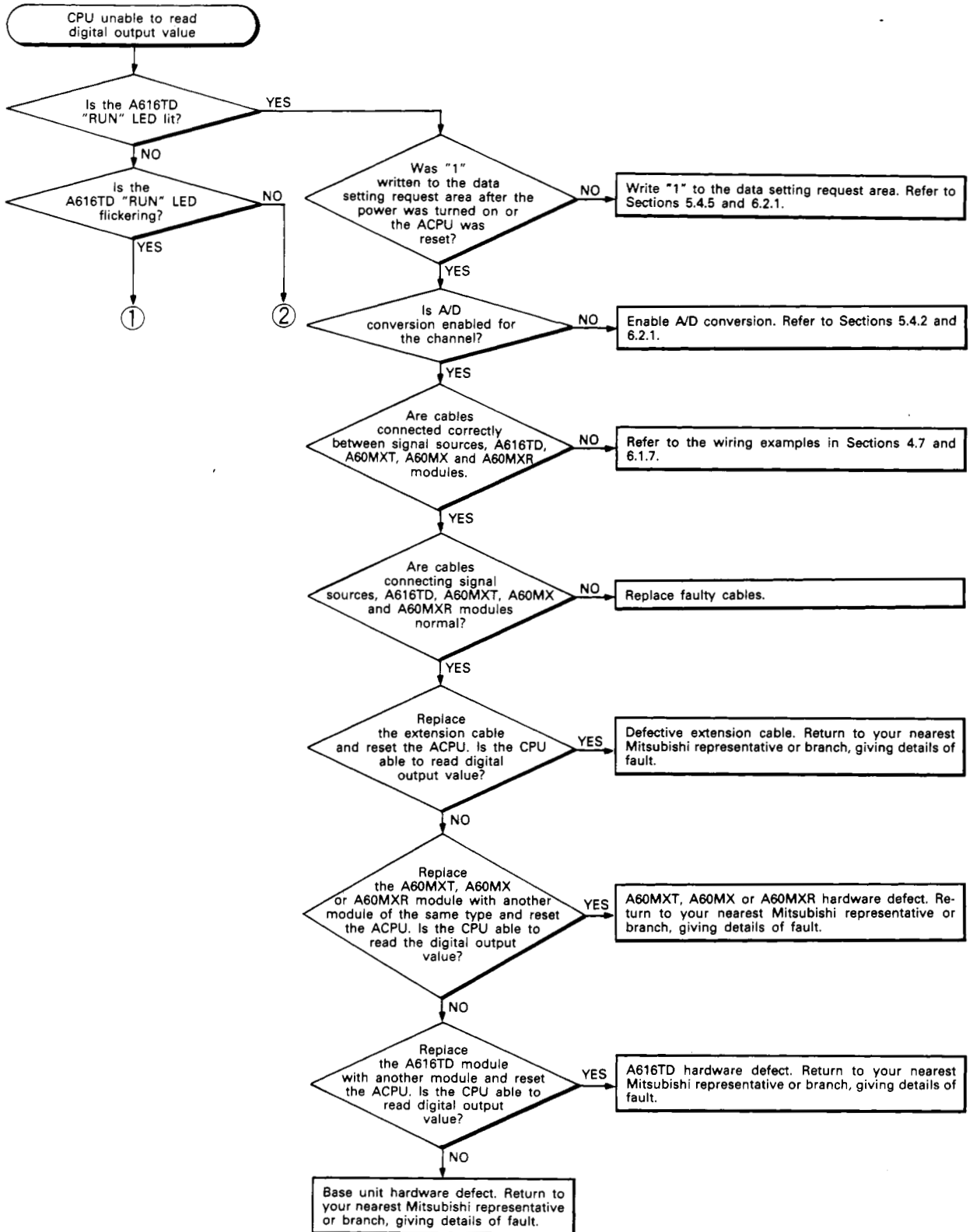

## 7. TROUBLESHOOTING

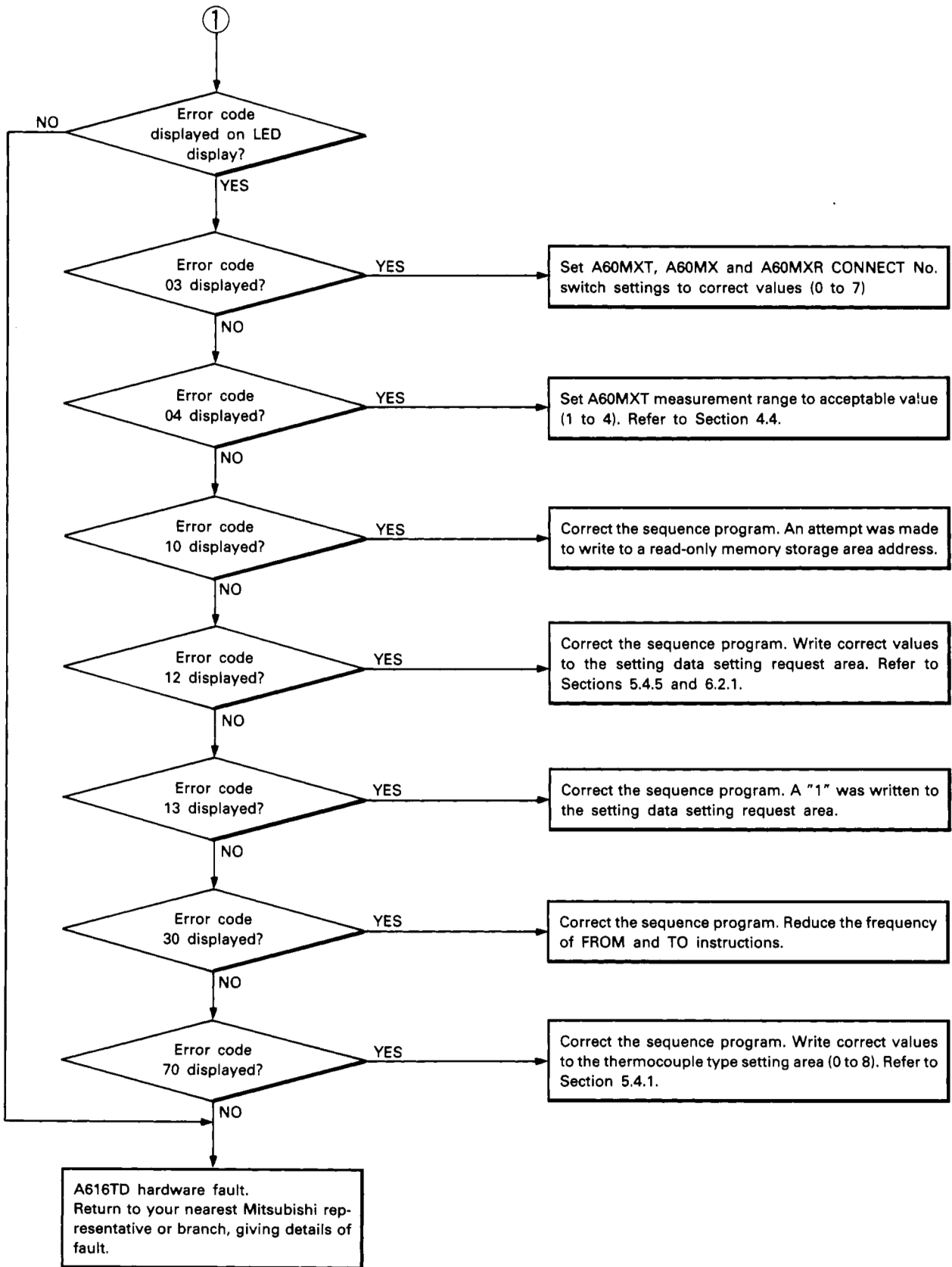



# 7. TROUBLESHOOTING

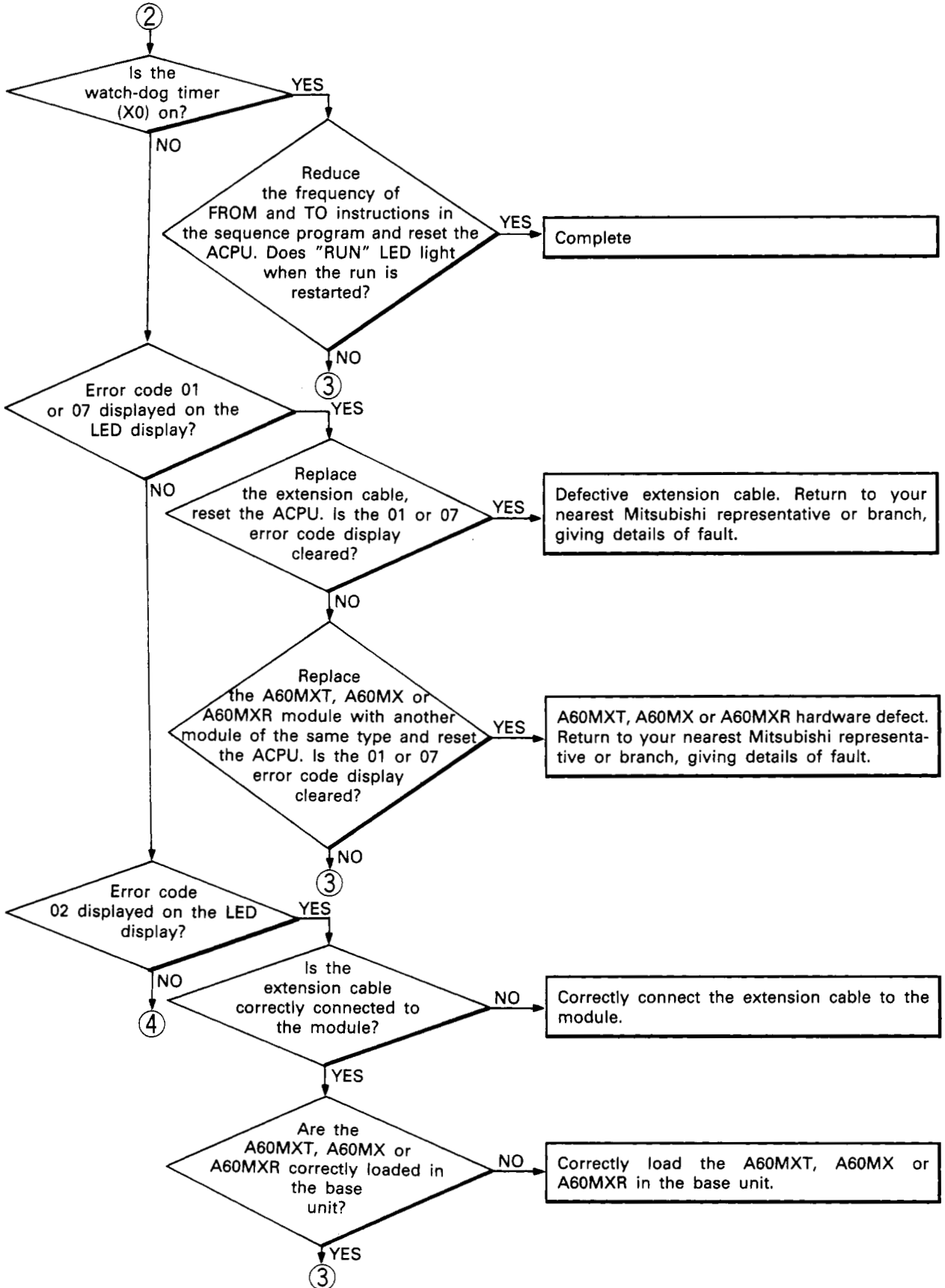

## 7. TROUBLESHOOTING

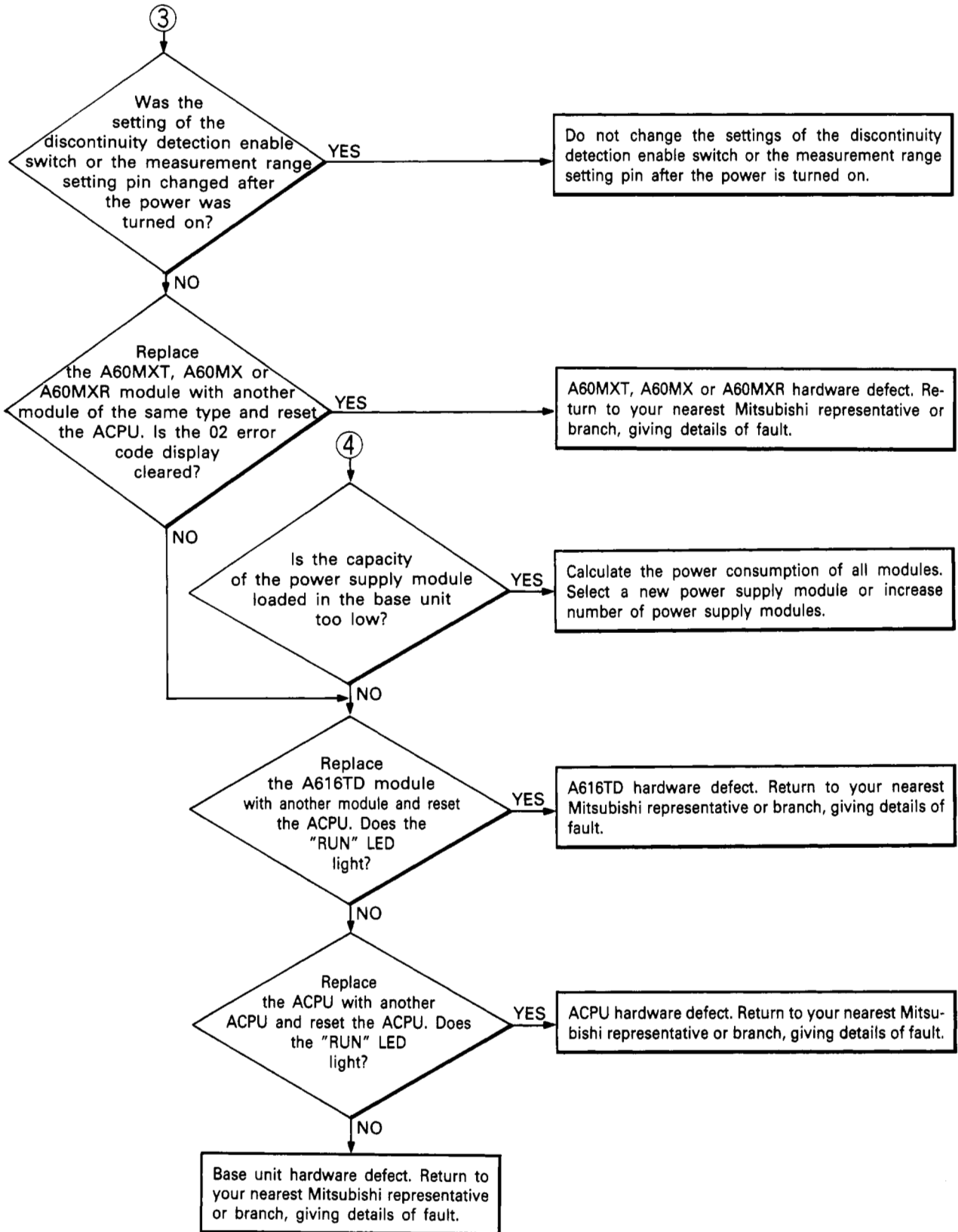

## 7. TROUBLESHOOTING

### 7.2.9 Watch-dog timer (WDT) error signal (X0) on

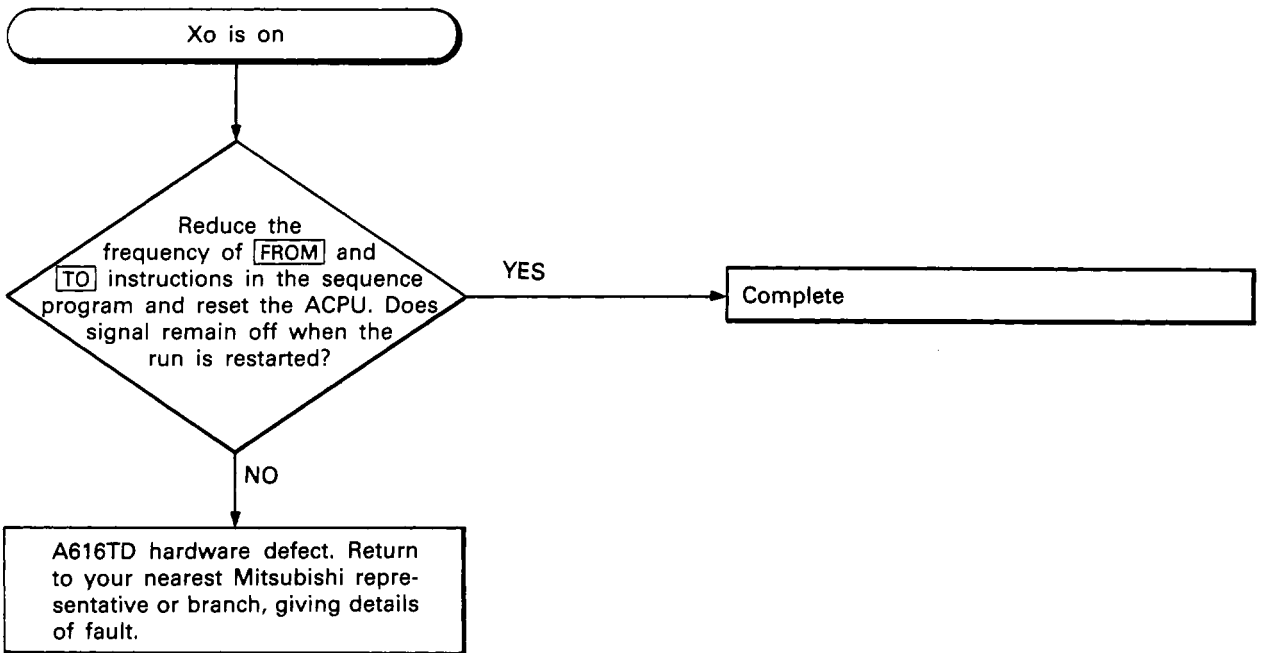

### 7.2.10 READY signal (X1) remains off

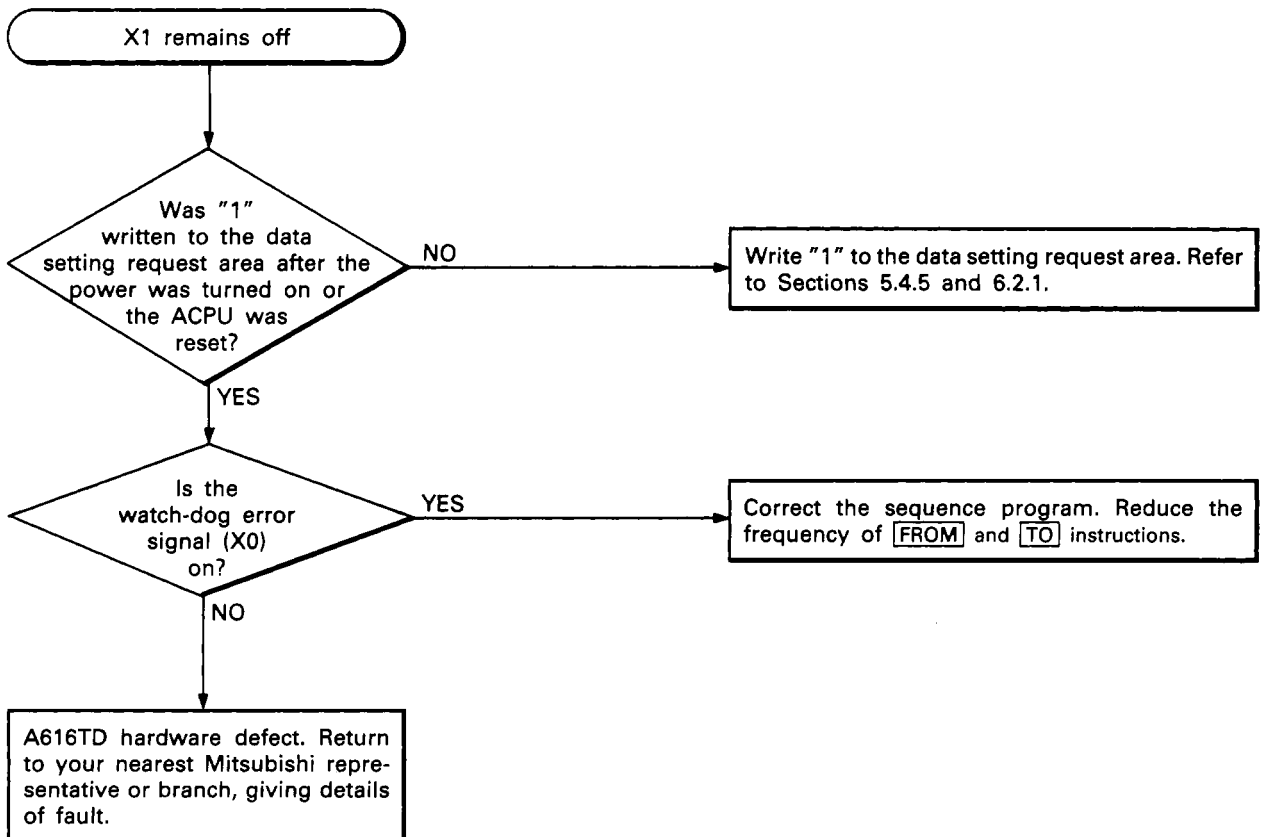

## 7. TROUBLESHOOTING

### 7.2.11 Discontinuity error detected (X3) or detected temperature output value out-of-range (X5) signal on

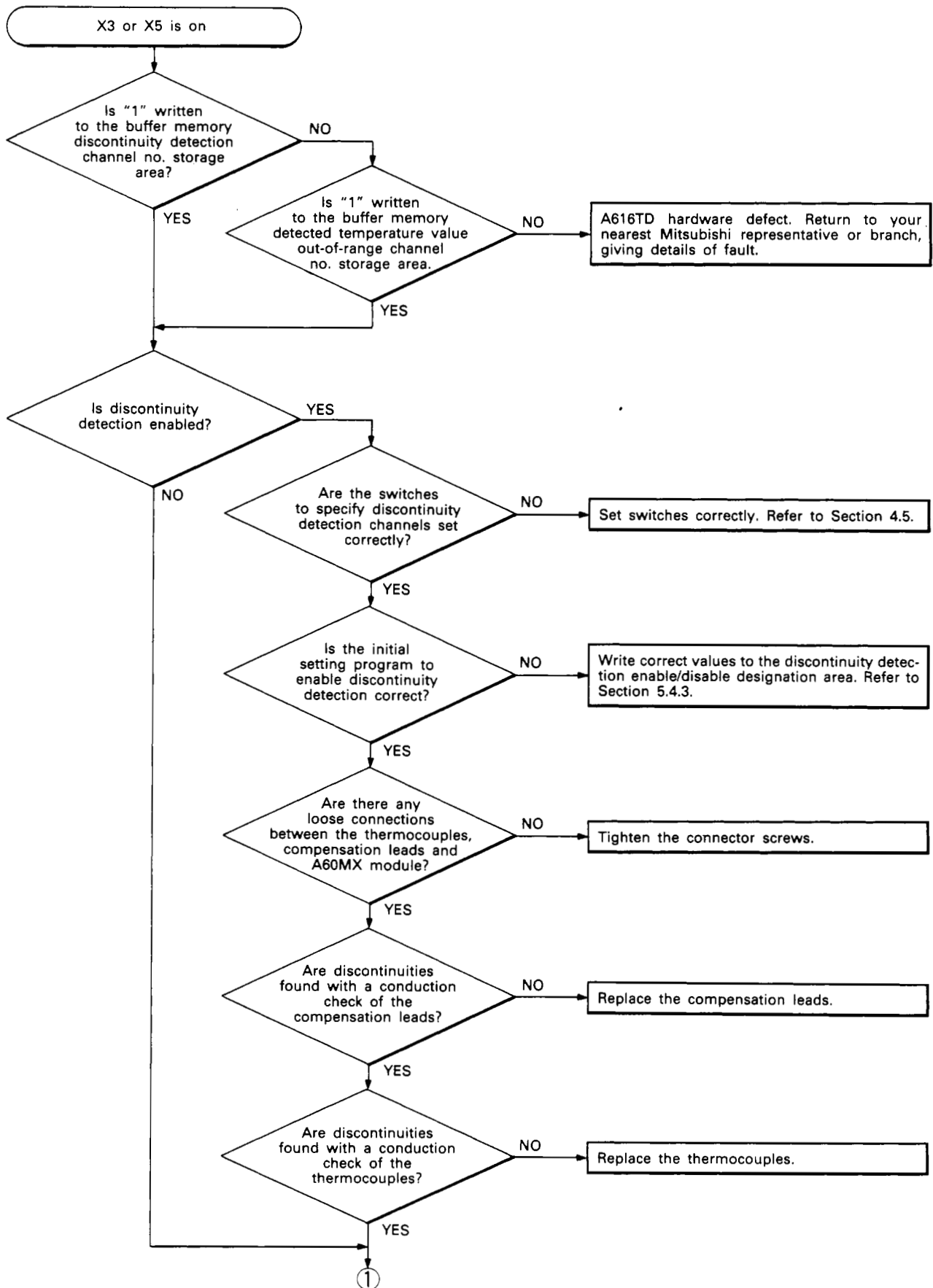

# 7. TROUBLESHOOTING

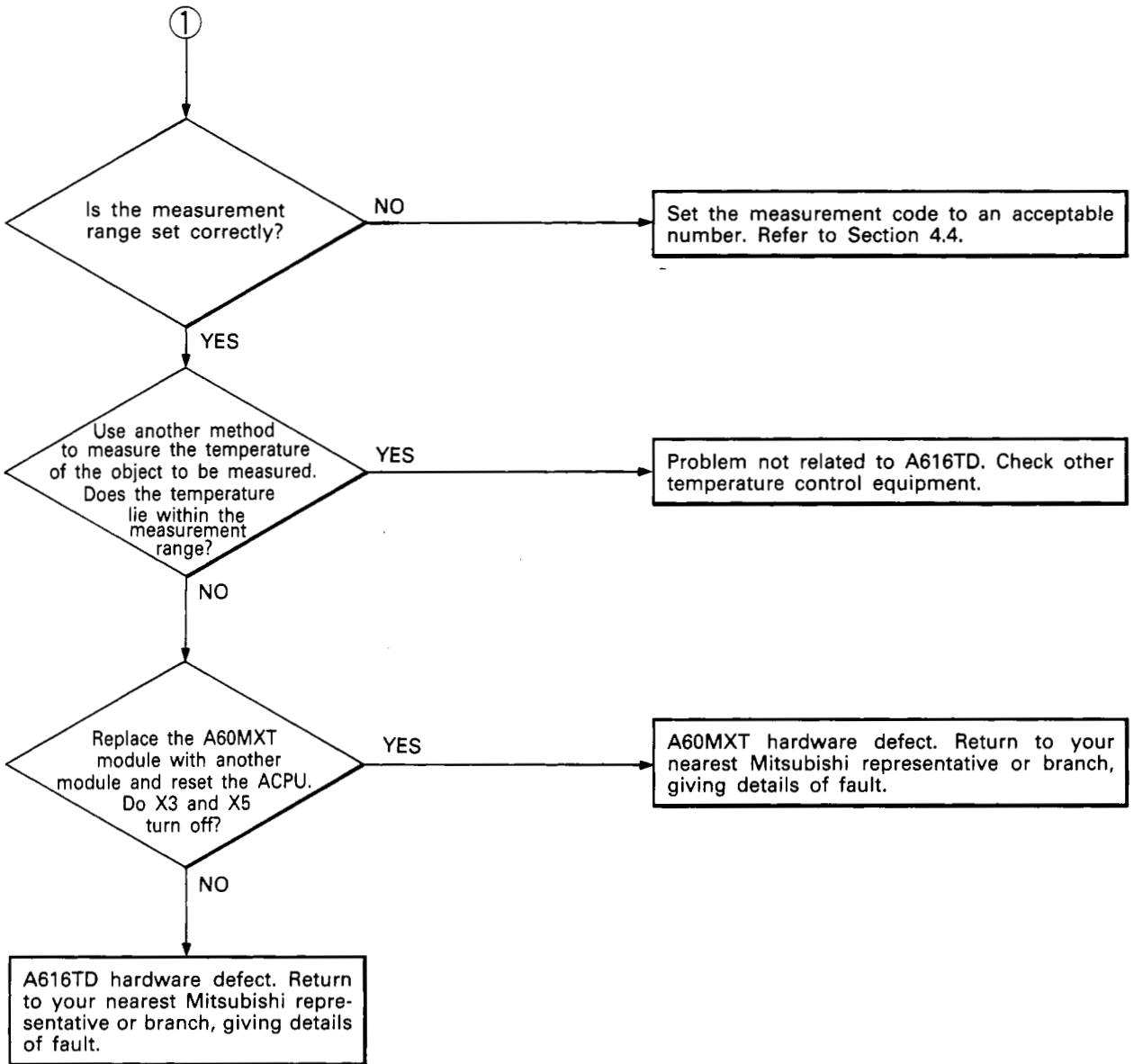

## 7. TROUBLESHOOTING

### 7.2.12 Digital output value out-of-range signal (X4) on

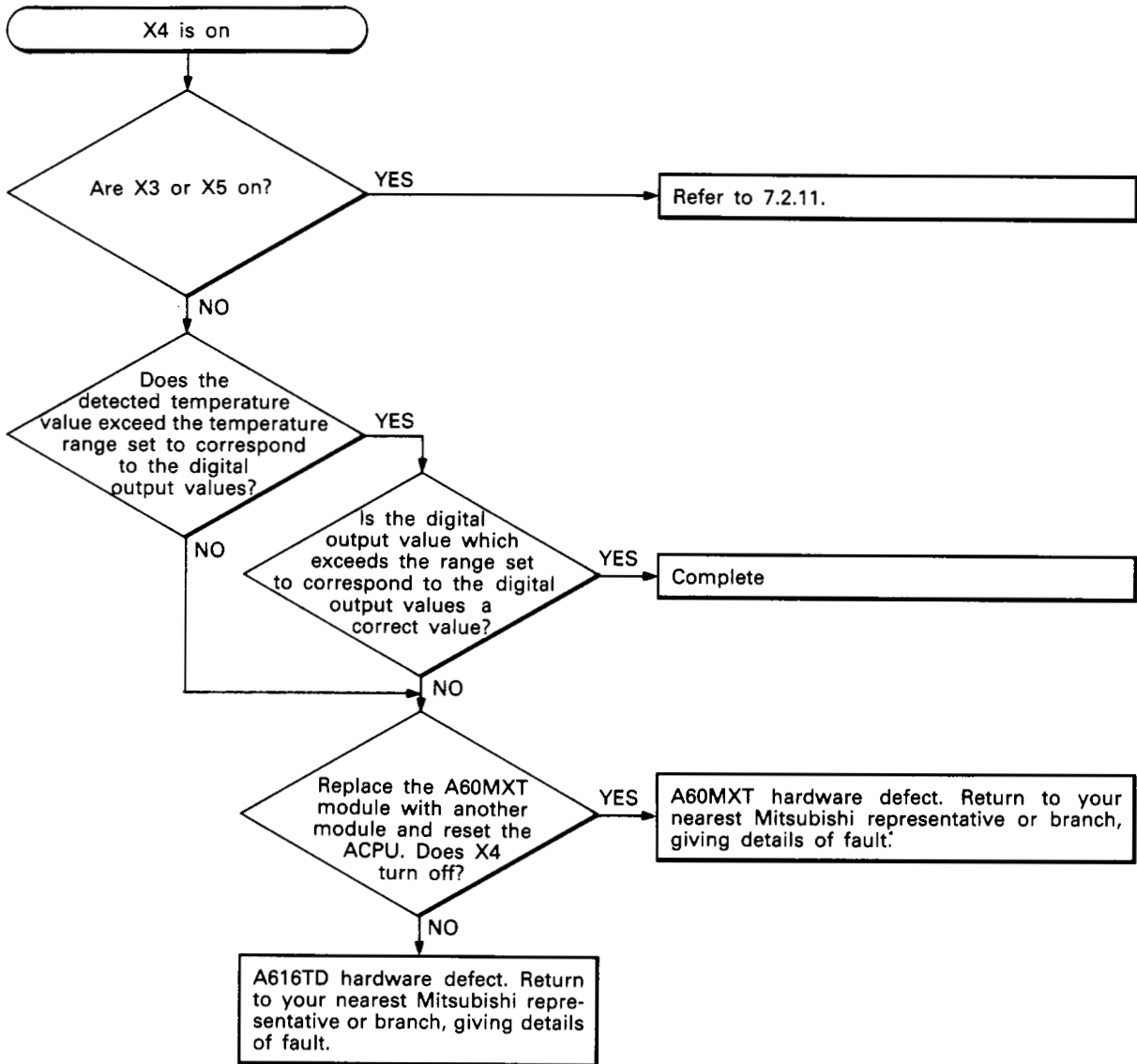

### 7.2.13 Detected temperature value not indicated if detected temperature value LED display request signal (Y10) turns on

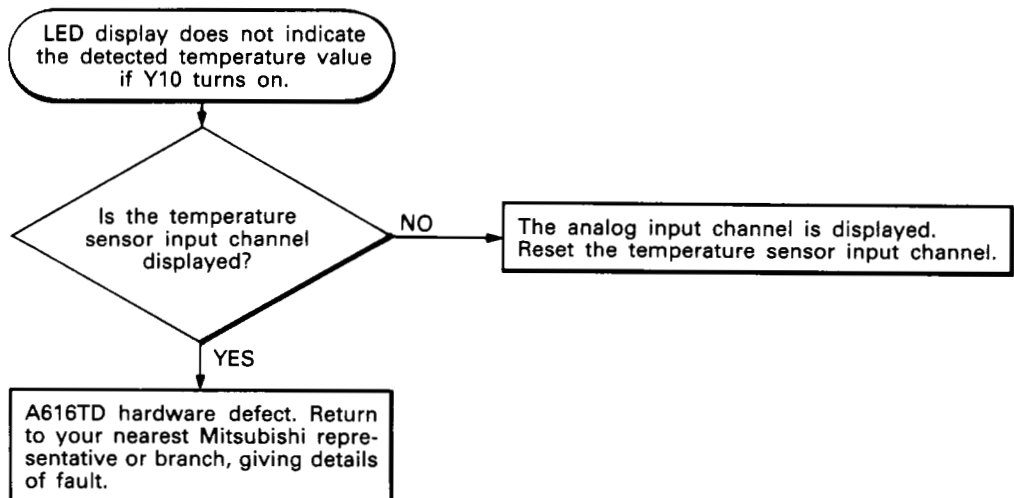

## 7. TROUBLESHOOTING

### 7.2.14 Rapid fluctuations of digital output value or detected temperature value during temperature sensor input

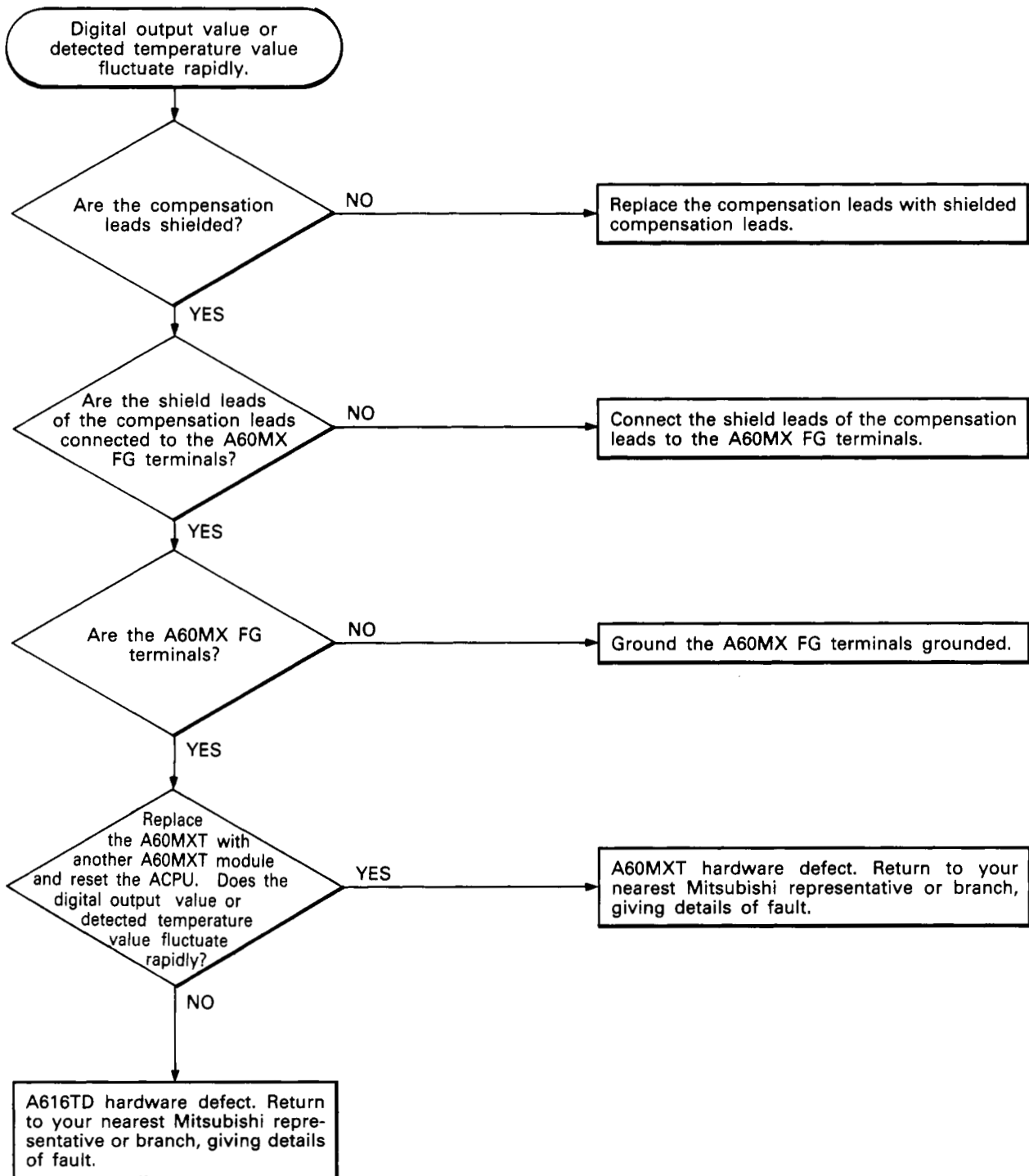

# 7. TROUBLESHOOTING

## 7.2.15 Digital output value fluctuates rapidly during analog input

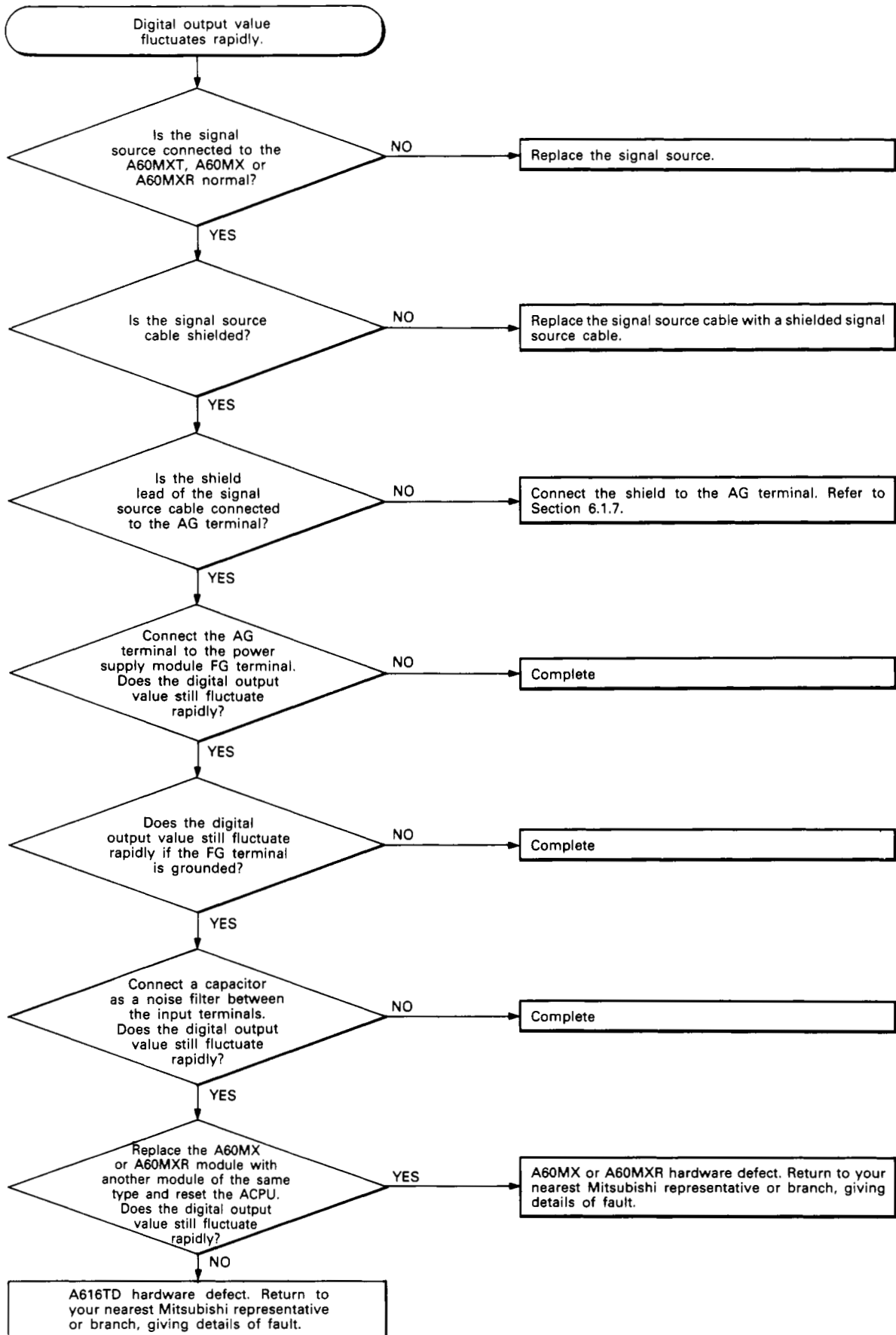



# 7. TROUBLESHOOTING

## 7.2.16 Error code indicated on LED display

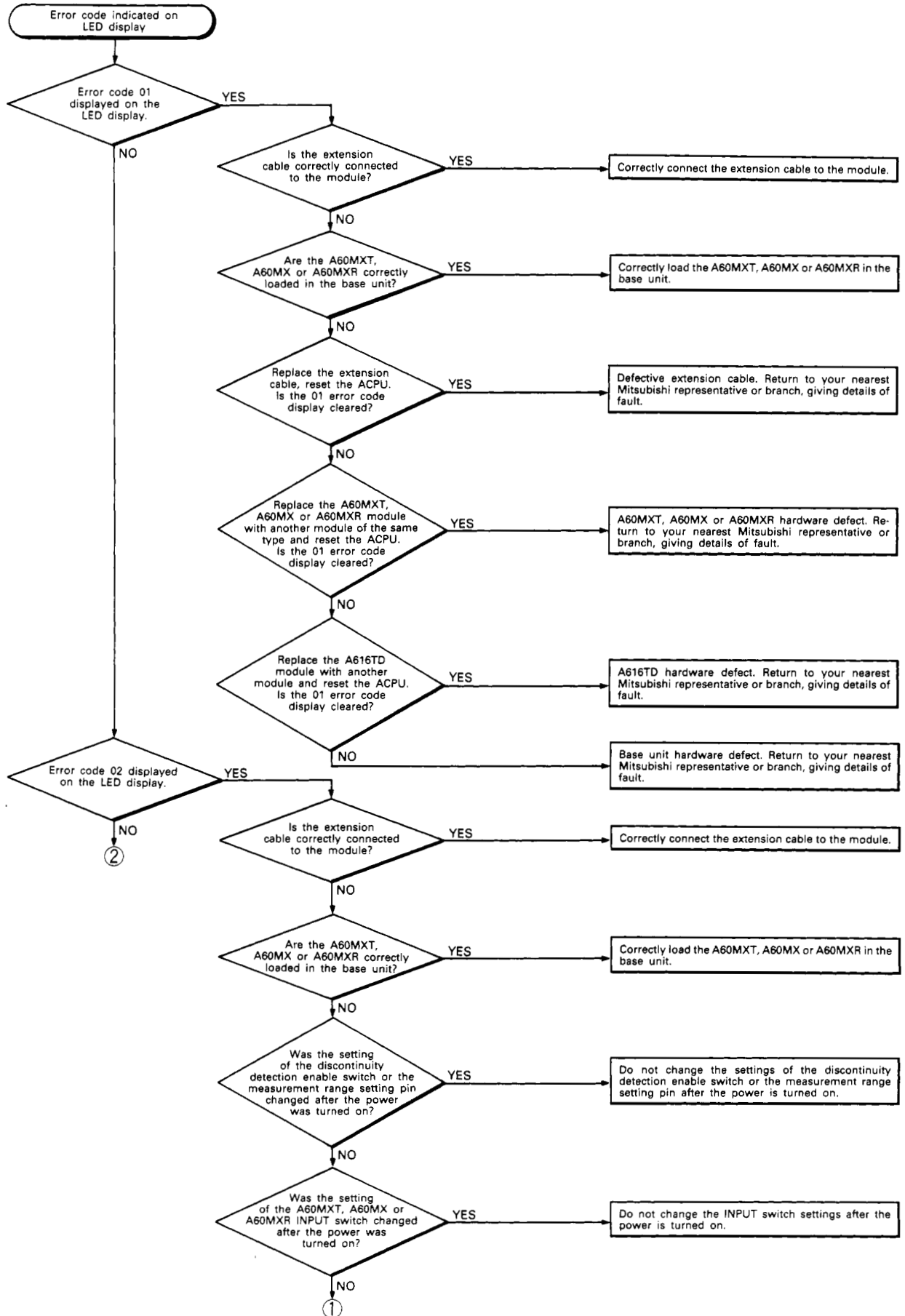

## 7. TROUBLESHOOTING

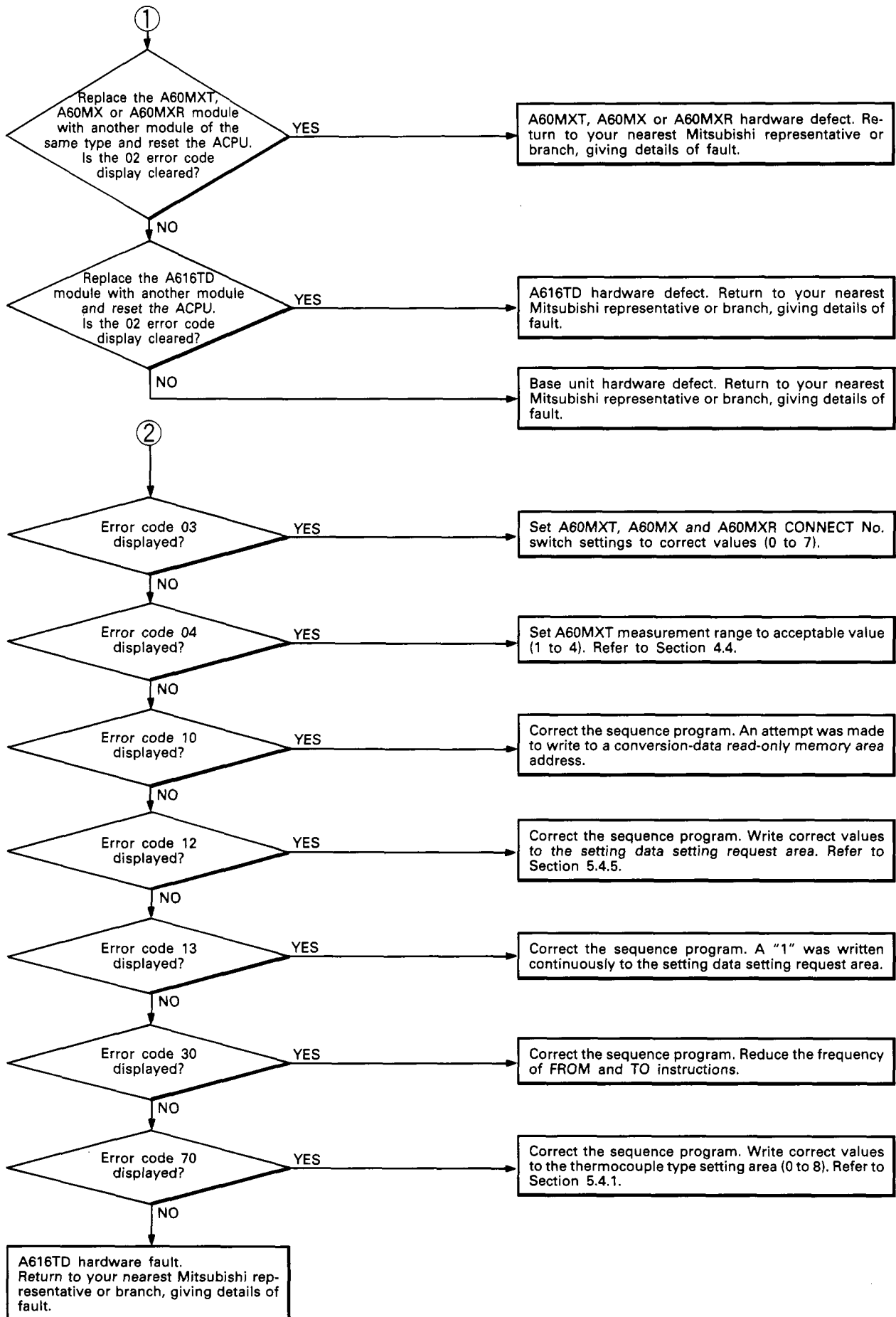

## 7. TROUBLESHOOTING

### 7.2.17 No correlation between temperature sensor input value and digital output value

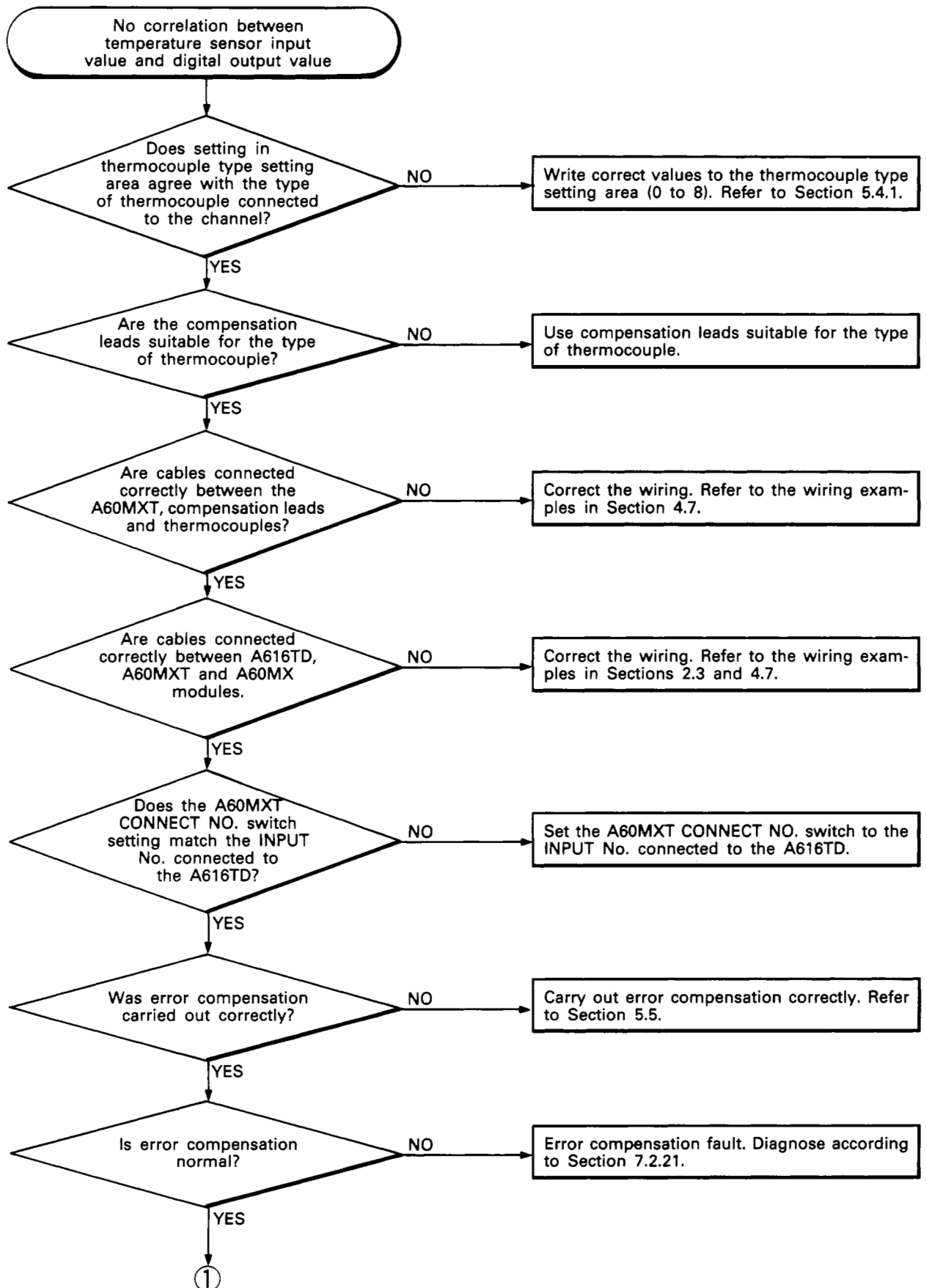

## 7. TROUBLESHOOTING

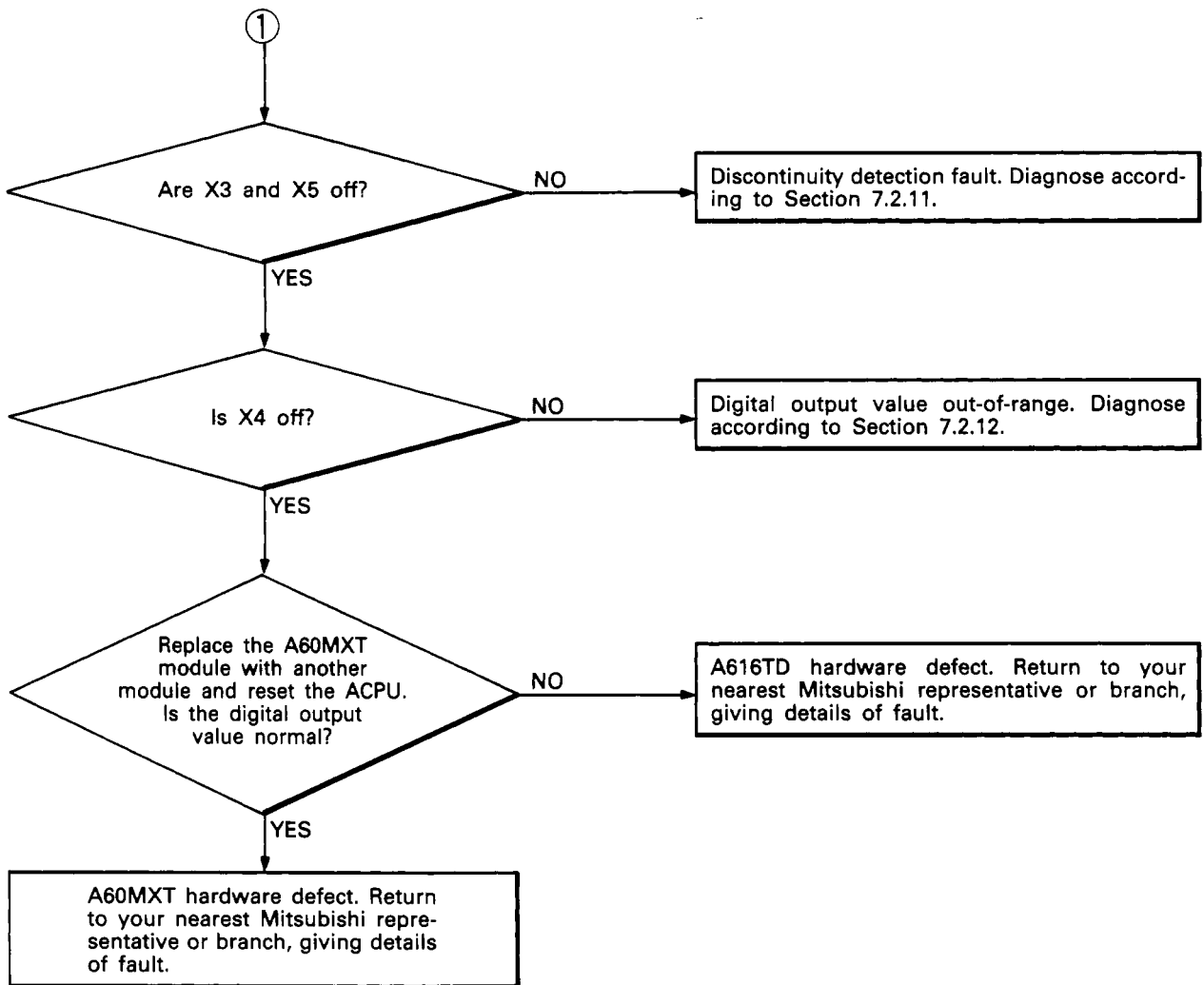

# 7. TROUBLESHOOTING

## 7.2.18 No correlation between analog input value and digital output value

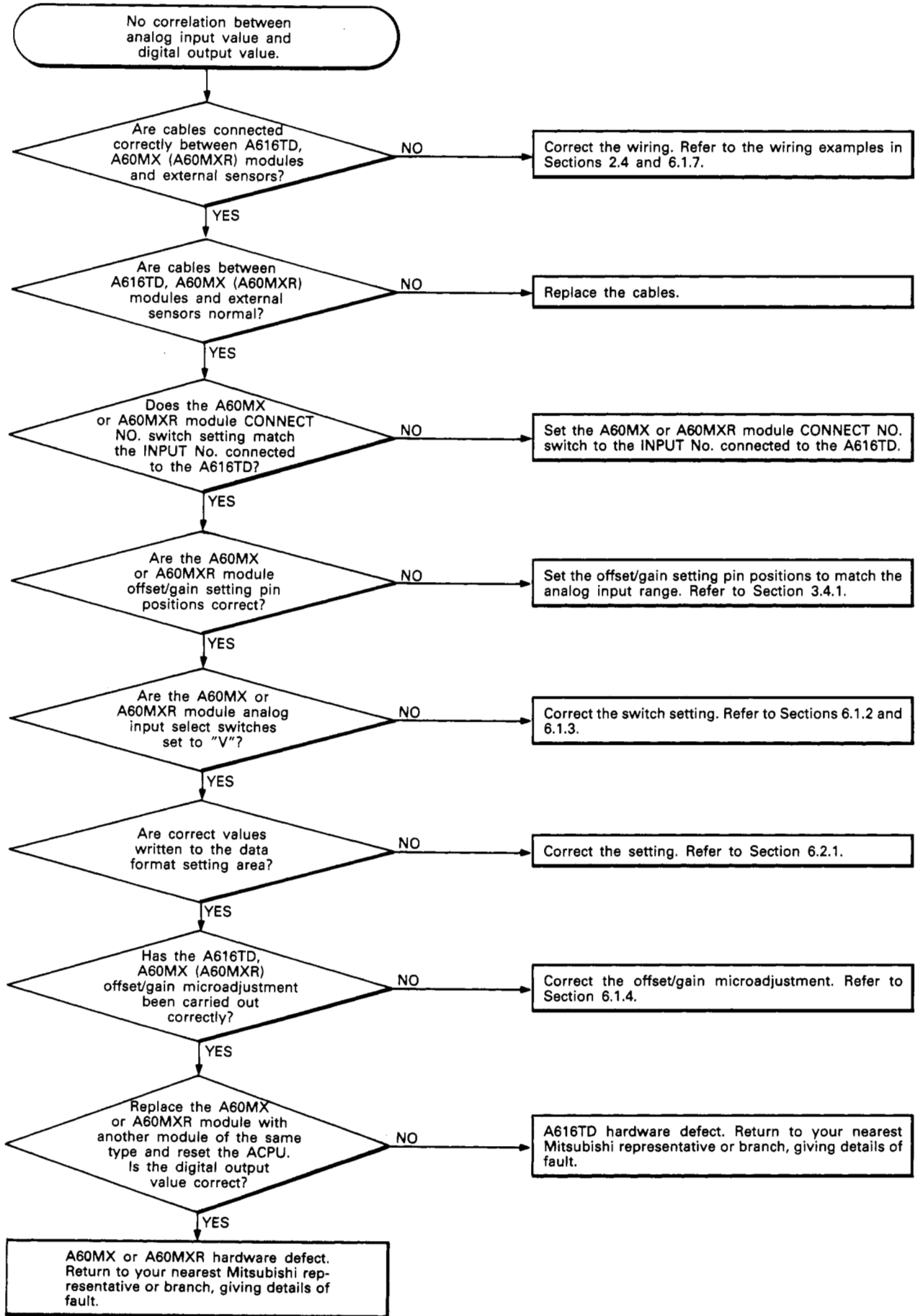

## 7. TROUBLESHOOTING

### 7.2.19 Constant digital output value deviation from reference value during temperature sensor input

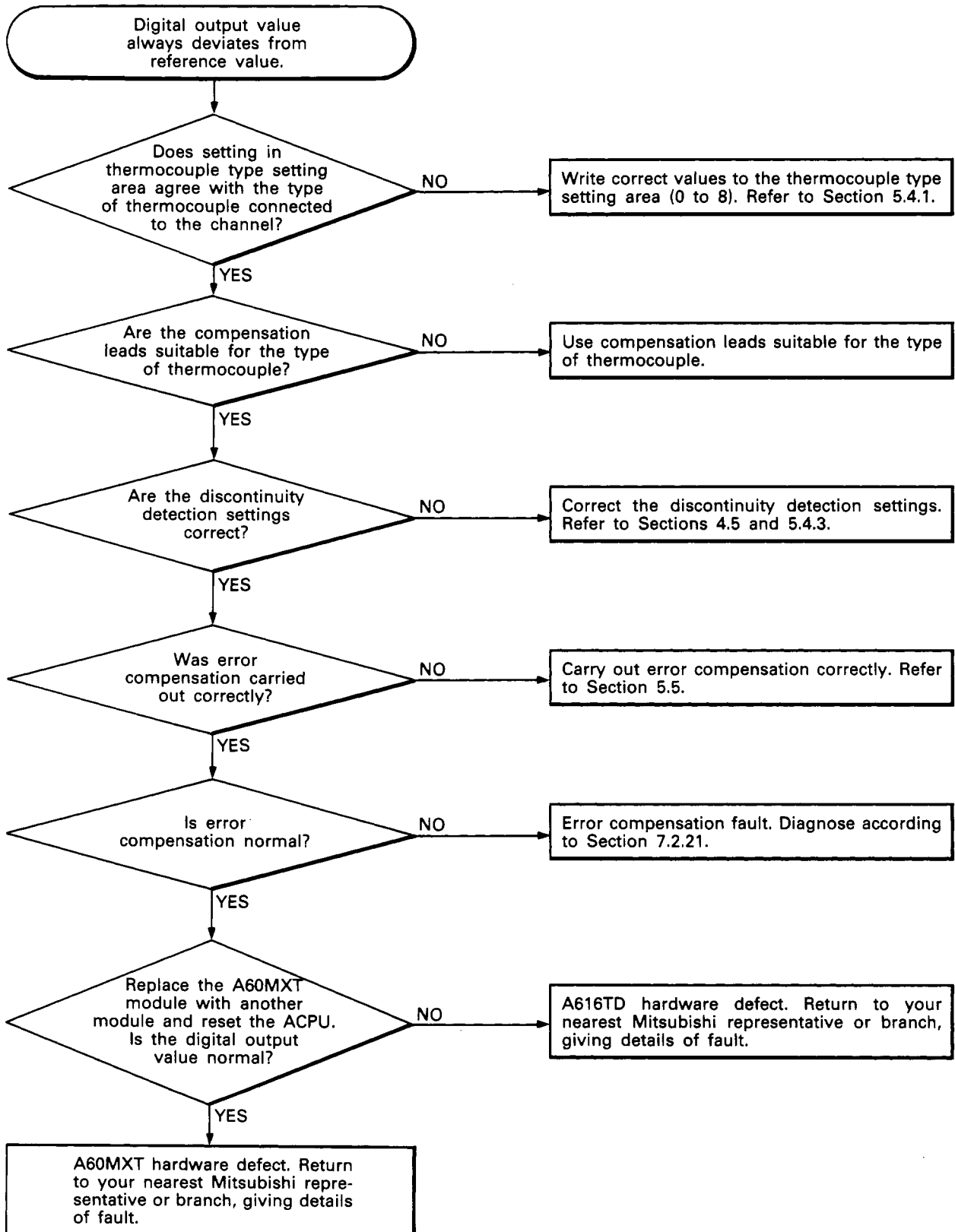

## 7. TROUBLESHOOTING

### 7.2.20 Constant digital output value deviation from reference value during analog input

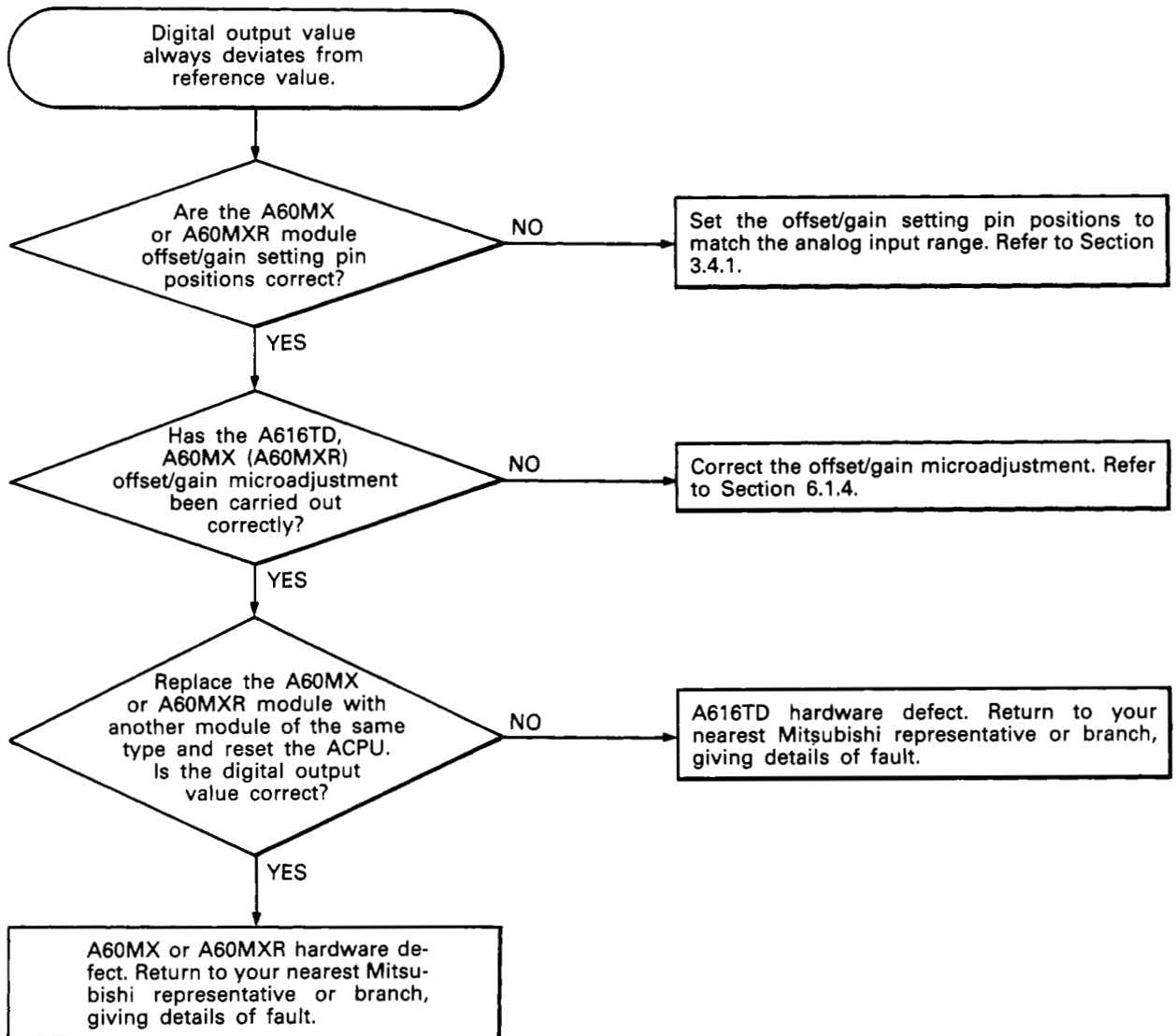

# 7. TROUBLESHOOTING

## 7.2.21 Error compensation is abnormal

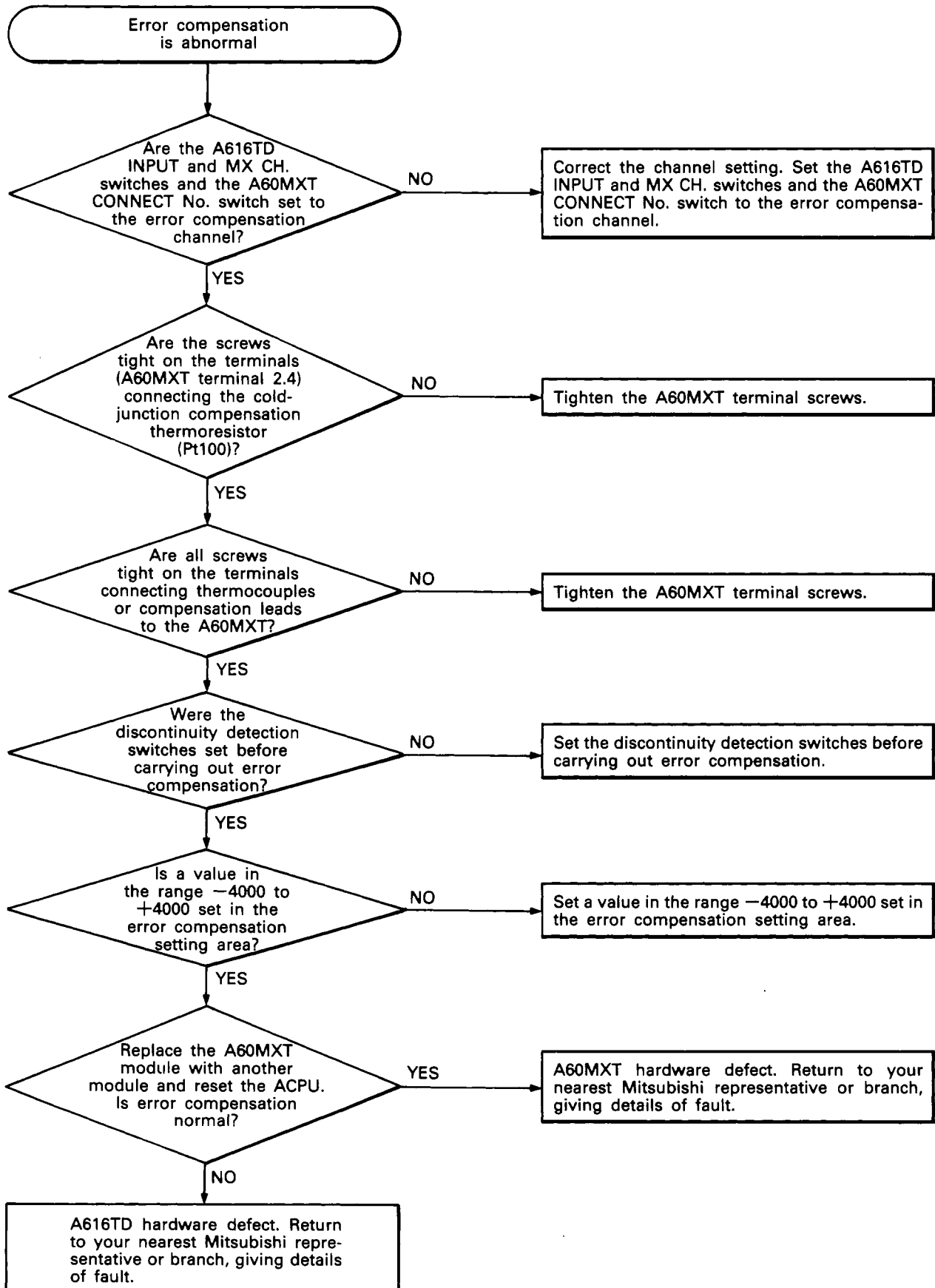



# APPENDICES

## APPENDICES

### Appendix 1 Thermocouple Normal and Overheat Temperature Limits

JIS C1602 - 1981

Material Code	Previous Code (reference)	Wire Diameter (mm)	Normal Temperature Limits (°C)	Overheat Temperature Limit (°C)
B	—	0.50	1500	1700
R	—	0.50	1400	1600
S				
K	CA	0.65	650	850
		1.00	750	950
		1.60	850	1050
		2.30	900	1100
		3.20	1000	1200
E	CRC	0.65	450	500
		1.00	500	550
		1.60	550	650
		2.30	600	750
		3.20	700	800
J	IC	0.65	400	500
		1.00	450	550
		1.60	500	650
		2.30	550	750
		3.20	600	750
T	CC	0.32	200	250
		0.65	200	250
		1.00	250	300
		1.60	300	350

Note: "Normal temperature limit" refers to the limit temperature for continuous operation of the thermocouple in air.

"Overheat temperature limit" refers to the limit temperature exceeding the normal temperature limit for short periods.

### Appendix 2 Temperature Tolerances

JIS C1602 - 1981

Material Code	Previous Code (reference)	Measured Temperature Range (°C)	Class	Tolerance
B	—	600 to 1700	0.5	$\pm 4^{\circ}\text{C}$ or measured temperature $\pm 0.5\%$
R	—	0 to 1600	0.25	$\pm 1.5^{\circ}\text{C}$ or measured temperature $\pm 0.25\%$
S				
K	CA	0 to 1000	0.4	$\pm 1.5^{\circ}\text{C}$ or measured temperature $\pm 0.4\%$
		0 to 1200	0.75	$\pm 2.5^{\circ}\text{C}$ or measured temperature $\pm 0.75\%$
		-200 to 0	1.5	$\pm 2.5^{\circ}\text{C}$ or measured temperature $\pm 1.5\%$
E	CRC	0 to 800	0.4	$\pm 1.5^{\circ}\text{C}$ or measured temperature $\pm 0.4\%$
		0 to 800	0.75	$\pm 2.5^{\circ}\text{C}$ or measured temperature $\pm 0.75\%$
		-200 to 0	1.5	$\pm 2.5^{\circ}\text{C}$ or measured temperature $\pm 1.5\%$
J	IC	0 to 750	0.4	$\pm 1.5^{\circ}\text{C}$ or measured temperature $\pm 0.4\%$
		0 to 750	0.75	$\pm 2.5^{\circ}\text{C}$ or measured temperature $\pm 0.75\%$
T	CC	0 to 350	0.4	$\pm 0.5^{\circ}\text{C}$ or measured temperature $\pm 0.4\%$
		0 to 350	0.75	$\pm 1^{\circ}\text{C}$ or measured temperature $\pm 0.75\%$
		-200 to 0	1.5	$\pm 1^{\circ}\text{C}$ or measured temperature $\pm 1.5\%$

Note: "Tolerance" refers to the maximum permitted limit of the difference in temperature between the temperature looked up in a standard thermoelectromotive force table corresponding to the thermoelectromotive force, and the measuring junction temperature.

The tolerance is taken as the larger of the temperature (°C) and percentage (%) values.

# APPENDICES

## Appendix 3 Thermoelectromotive Force Tables

**Type B**

### 3.1 Standard thermoelectromotive force tables for type B thermocouples

JIS C1602-1981 (Complying with ANSI MC 96. 1-1975, BS1041-1966 and DIN43710-1977.)

Units :  $\mu\text{V}$

Temperature (°C)	0	1	2	3	4	5	6	7	8	9	Temperature (°C)
0	0	-0	-0	-1	-1	-1	-1	-1	-2	-2	0
10	-2	-2	-2	-2	-2	-2	-2	-2	-3	-3	10
20	-3	-3	-3	-3	-3	-2	-2	-2	-2	-2	20
30	-2	-2	-2	-2	-2	-1	-1	-1	-1	-1	30
40	-0	-0	-0	0	0	1	1	1	2	2	40
50	2	3	3	3	4	4	4	5	5	6	50
60	6	7	7	8	8	9	9	10	10	11	60
70	11	12	12	13	14	14	15	15	16	17	70
80	17	18	19	20	20	21	22	22	23	24	80
90	25	26	26	27	28	29	30	31	31	32	90
100	33	34	35	36	37	38	39	40	41	42	100
110	43	44	45	46	47	48	49	50	51	52	110
120	53	55	56	57	58	59	60	62	63	64	120
130	65	66	68	69	70	71	73	74	75	77	130
140	78	79	81	82	83	85	86	88	89	91	140
150	92	93	95	96	98	99	101	102	104	106	150
160	107	109	110	112	113	115	117	118	120	122	160
170	123	125	127	128	130	132	133	135	137	139	170
180	140	142	144	146	148	149	151	153	155	157	180
190	159	161	163	164	166	168	170	172	174	176	190
200	178	180	182	184	186	188	190	192	194	197	200
210	199	201	203	205	207	209	211	214	216	218	210
220	220	222	225	227	229	231	234	236	238	240	220
230	243	245	247	250	252	254	257	259	262	264	230
240	266	269	271	274	276	279	281	284	286	289	240
250	291	294	296	299	301	304	307	309	312	314	250
260	317	320	322	325	328	330	333	336	338	341	260
270	344	347	349	352	355	358	360	363	366	369	270
280	372	375	377	380	383	386	389	392	395	398	280
290	401	404	406	409	412	415	418	421	424	427	290
300	431	434	437	440	443	446	449	452	455	458	300
310	462	465	468	471	474	477	481	484	487	490	310
320	494	497	500	503	507	510	513	517	520	523	320
330	527	530	533	537	540	544	547	550	554	557	330
340	561	564	568	571	575	578	582	585	589	592	340
350	596	599	603	606	610	614	617	621	625	628	350
360	632	636	639	643	647	650	654	658	661	665	360
370	669	673	677	680	684	688	692	696	699	703	370
380	707	711	715	719	723	727	730	734	738	742	380
390	746	750	754	758	762	766	770	774	778	782	390
400	786	790	794	799	803	807	811	815	819	823	400
410	827	832	836	840	844	848	853	857	861	865	410
420	870	874	878	882	887	891	895	900	904	908	420
430	913	917	921	926	930	935	939	943	948	952	430
440	957	961	966	970	975	979	984	988	993	997	440
450	1002	1006	1011	1015	1020	1025	1029	1034	1039	1043	450
460	1048	1052	1057	1062	1066	1071	1076	1081	1085	1090	460
470	1095	1100	1104	1109	1114	1119	1123	1128	1133	1138	470
480	1143	1148	1152	1157	1162	1167	1172	1177	1182	1187	480
490	1192	1197	1202	1206	1211	1216	1221	1226	1231	1236	490

# APPENDICES

## Type B

JIS C1602-1981 (Complying with ANSI MC 96. 1-1975, BS1041-1966 and DIN43710-1977.)

Units :  $\mu$ V

Temperature (°C)	0	1	2	3	4	5	6	7	8	9	Temperature (°C)
500	1241	1246	1252	1257	1262	1267	1272	1277	1282	1287	500
510	1292	1297	1303	1308	1313	1318	1323	1328	1334	1339	510
520	1344	1349	1354	1360	1365	1370	1375	1381	1386	1391	520
530	1397	1402	1407	1413	1418	1423	1429	1434	1439	1445	530
540	1450	1456	1461	1467	1472	1477	1483	1488	1494	1499	540
550	1505	1510	1516	1521	1527	1532	1538	1544	1549	1555	550
560	1560	1566	1571	1577	1583	1588	1594	1600	1605	1611	560
570	1617	1622	1628	1634	1639	1645	1651	1657	1662	1668	570
580	1674	1680	1685	1691	1697	1703	1709	1715	1720	1726	580
590	1732	1738	1744	1750	1756	1762	1767	1773	1779	1785	590
600	1791	1797	1803	1809	1815	1821	1827	1833	1839	1845	600
610	1851	1857	1863	1869	1875	1882	1888	1894	1900	1906	610
620	1912	1918	1924	1931	1937	1943	1949	1955	1961	1968	620
630	1974	1980	1986	1993	1999	2005	2011	2018	2024	2030	630
640	2036	2043	2049	2055	2062	2068	2074	2081	2087	2094	640
650	2100	2106	2113	2119	2126	2132	2139	2145	2151	2158	650
660	2164	2171	2177	2184	2190	2197	2203	2210	2216	2223	660
670	2230	2236	2243	2249	2256	2263	2269	2276	2282	2289	670
680	2296	2302	2309	2316	2322	2329	2336	2343	2349	2356	680
690	2363	2369	2376	2383	2390	2396	2403	2410	2417	2424	690
700	2430	2437	2444	2451	2458	2465	2472	2478	2485	2492	700
710	2499	2506	2513	2520	2527	2534	2541	2548	2555	2562	710
720	2569	2576	2583	2590	2597	2604	2611	2618	2625	2632	720
730	2639	2646	2653	2660	2667	2674	2682	2689	2696	2703	730
740	2710	2717	2724	2732	2739	2746	2753	2760	2768	2775	740
750	2782	2789	2797	2804	2811	2818	2826	2833	2840	2848	750
760	2855	2862	2869	2877	2884	2892	2899	2906	2914	2921	760
770	2928	2936	2943	2951	2958	2966	2973	2980	2988	2995	770
780	3003	3010	3018	3025	3033	3040	3048	3055	3063	3070	780
790	3078	3086	3093	3101	3108	3116	3124	3131	3139	3146	790
800	3154	3162	3169	3177	3185	3192	3200	3208	3215	3223	800
810	3231	3239	3246	3254	3262	3269	3277	3285	3293	3301	810
820	3308	3316	3324	3332	3340	3347	3355	3363	3371	3379	820
830	3387	3395	3402	3410	3418	3426	3434	3442	3450	3458	830
840	3466	3474	3482	3490	3498	3506	3514	3522	3530	3538	840
850	3546	3554	3562	3570	3578	3586	3594	3602	3610	3618	850
860	3626	3634	3643	3651	3659	3667	3675	3683	3691	3700	860
870	3708	3716	3724	3732	3741	3749	3757	3765	3773	3782	870
880	3790	3798	3806	3815	3823	3831	3840	3848	3856	3865	880
890	3873	3881	3890	3898	3906	3915	3923	3931	3940	3948	890
900	3957	3965	3973	3982	3990	3999	4007	4016	4024	4032	900
910	4041	4049	4058	4066	4075	4083	4092	4100	4109	4117	910
920	4126	4135	4143	4152	4160	4169	4177	4186	4195	4203	920
930	4212	4220	4229	4238	4246	4255	4264	4272	4281	4290	930
940	4298	4307	4316	4325	4333	4342	4351	4359	4368	4377	940
950	4386	4394	4403	4412	4421	4430	4438	4447	4456	4465	950
960	4474	4483	4491	4500	4509	4518	4527	4536	4545	4553	960
970	4562	4571	4580	4589	4598	4607	4616	4625	4634	4643	970
980	4652	4661	4670	4679	4688	4697	4706	4715	4724	4733	980
990	4742	4751	4760	4769	4778	4787	4796	4805	4814	4824	990

# APPENDICES

**Type B**

JIS C1602-1981 (Complying with ANSI MC 96. 1-1975, BS1041-1966 and DIN43710-1977.)

Units :  $\mu V$

Temperature (°C)	0	1	2	3	4	5	6	7	8	9	Temperature (°C)
1000	4833	4842	4851	4860	4869	4878	4887	4897	4906	4915	1000
1010	4924	4933	4942	4952	4961	4970	4979	4989	4998	5007	1010
1020	5016	5025	5035	5044	5053	5063	5072	5081	5090	5100	1020
1030	5109	5118	5128	5137	5146	5156	5165	5174	5184	5193	1030
1040	5202	5212	5221	5231	5240	5249	5259	5268	5278	5287	1040
1050	5297	5306	5316	5325	5334	5344	5353	5363	5372	5382	1050
1060	5391	5401	5410	5420	5429	5439	5449	5458	5468	5477	1060
1070	5487	5496	5506	5516	5525	5535	5544	5554	5564	5573	1070
1080	5583	5593	5602	5612	5621	5631	5641	5651	5660	5670	1080
1090	5680	5689	5699	5709	5718	5728	5738	5748	5757	5767	1090
1100	5777	5787	5796	5806	5816	5826	5836	5845	5855	5865	1100
1110	5875	5885	5895	5904	5914	5924	5934	5944	5954	5964	1110
1120	5973	5983	5993	6003	6013	6023	6033	6043	6053	6063	1120
1130	6073	6083	6093	6102	6112	6122	6132	6142	6152	6162	1130
1140	6172	6182	6192	6202	6212	6223	6233	6243	6253	6263	1140
1150	6273	6283	6293	6303	6313	6323	6333	6343	6353	6364	1150
1160	6374	6384	6394	6404	6414	6424	6435	6445	6455	6465	1160
1170	6475	6485	6496	6506	6516	6526	6536	6547	6557	6567	1170
1180	6577	6588	6598	6608	6618	6629	6639	6649	6659	6670	1180
1190	6680	6690	6701	6711	6721	6732	6742	6752	6763	6773	1190
1200	6783	6794	6804	6814	6825	6835	6846	6856	6866	6877	1200
1210	6887	6898	6908	6918	6929	6939	6950	6960	6971	6981	1210
1220	6991	7002	7012	7023	7033	7044	7054	7065	7075	7086	1220
1230	7096	7107	7117	7128	7138	7149	7159	7170	7181	7191	1230
1240	7202	7212	7223	7233	7244	7255	7265	7276	7286	7297	1240
1250	7308	7318	7329	7339	7350	7361	7371	7382	7393	7403	1250
1260	7414	7425	7435	7446	7457	7467	7478	7489	7500	7510	1260
1270	7521	7532	7542	7553	7564	7575	7585	7596	7607	7618	1270
1280	7628	7639	7650	7661	7671	7682	7693	7704	7715	7725	1280
1290	7736	7747	7758	7769	7780	7790	7801	7812	7823	7834	1290
1300	7845	7855	7866	7877	7888	7899	7910	7921	7932	7943	1300
1310	7953	7964	7975	7986	7997	8008	8019	8030	8041	8052	1310
1320	8063	8074	8085	8096	8107	8118	8128	8139	8150	8161	1320
1330	8172	8183	8194	8205	8216	8227	8238	8249	8261	8272	1330
1340	8283	8294	8305	8316	8327	8338	8349	8360	8371	8382	1340
1350	8393	8404	8415	8426	8437	8449	8460	8471	8482	8493	1350
1360	8504	8515	8526	8538	8549	8560	8571	8582	8593	8604	1360
1370	8616	8627	8638	8649	8660	8671	8683	8694	8705	8716	1370
1380	8727	8738	8750	8761	8772	8783	8795	8806	8817	8828	1380
1390	8839	8851	8862	8873	8884	8896	8907	8918	8929	8941	1390
1400	8952	8963	8974	8986	8997	9008	9020	9031	9042	9053	1400
1410	9065	9076	9087	9099	9110	9121	9133	9144	9155	9167	1410
1420	9178	9189	9201	9212	9223	9235	9246	9257	9269	9280	1420
1430	9291	9303	9314	9326	9337	9348	9360	9371	9382	9394	1430
1440	9405	9417	9428	9439	9451	9462	9474	9485	9497	9508	1440
1450	9519	9531	9542	9554	9565	9577	9588	9599	9611	9622	1450
1460	9634	9645	9657	9668	9680	9691	9703	9714	9726	9737	1460
1470	9748	9760	9771	9783	9794	9806	9817	9829	9840	9852	1470
1480	9863	9875	9886	9898	9909	9921	9933	9944	9956	9967	1480
1490	9979	9990	10002	10013	10025	10036	10048	10059	10071	10082	1490

# APPENDICES

**Type B**

JIS C1602-1981 (Complying with ANSI MC 96. 1-1975, BS1041-1966 and DIN43710-1977.)

Units :  $\mu V$

Temperature (°C)	0	1	2	3	4	5	6	7	8	9	Temperature (°C)
1500	10094	10106	10117	10129	10140	10152	10163	10175	10187	10198	1500
1510	10210	10221	10233	10244	10256	10268	10279	10291	10302	10314	1510
1520	10325	10337	10349	10360	10372	10383	10395	10407	10418	10430	1520
1530	10441	10453	10465	10476	10488	10500	10511	10523	10534	10546	1530
1540	10558	10569	10581	10593	10604	10616	10627	10639	10651	10662	1540
1550	10674	10686	10697	10709	10721	10732	10744	10756	10767	10779	1550
1560	10790	10802	10814	10825	10837	10849	10860	10872	10884	10895	1560
1570	10907	10919	10930	10942	10954	10965	10977	10989	11000	11012	1570
1580	11024	11035	11047	11059	11070	11082	11094	11105	11117	11129	1580
1590	11141	11152	11164	11176	11187	11199	11211	11222	11234	11246	1590
1600	11257	11269	11281	11292	11304	11316	11328	11339	11351	11363	1600
1610	11374	11386	11398	11409	11421	11433	11444	11456	11468	11480	1610
1620	11491	11503	11515	11526	11538	11550	11561	11573	11585	11597	1620
1630	11608	11620	11632	11643	11655	11667	11678	11690	11702	11714	1630
1640	11725	11737	11749	11760	11772	11784	11795	11807	11819	11830	1640
1650	11842	11854	11866	11877	11889	11901	11912	11924	11936	11947	1650
1660	11959	11971	11983	11994	12006	12018	12029	12041	12053	12064	1660
1670	12076	12088	12099	12111	12123	12134	12146	12158	12170	12181	1670
1680	12193	12205	12216	12228	12240	12251	12263	12275	12286	12298	1680
1690	12310	12321	12333	12345	12356	12368	12380	12391	12403	12415	1690
1700	12426	12438	12450	12461	12473	12485	12496	12508	12520	12531	1700
1710	12543	12555	12566	12578	12590	12601	12613	12624	12636	12648	1710
1720	12659	12671	12683	12694	12706	12718	12729	12741	12752	12764	1720
1730	12776	12787	12799	12811	12822	12834	12845	12857	12869	12880	1730
1740	12892	12903	12915	12927	12938	12950	12961	12973	12985	12996	1740
1750	13008	13019	13031	13043	13054	13066	13077	13089	13100	13112	1750
1760	13124	13135	13147	13158	13170	13181	13193	13204	13216	13228	1760
1770	13239	13251	13262	13274	13285	13297	13308	13320	13331	13343	1770
1780	13354	13366	13378	13389	13401	13412	13424	13435	13447	13458	1780
1790	13470	13481	13493	13504	13516	13527	13539	13550	13562	13573	1790
1800	13585	13596	13607	13619	13630	13642	13653	13665	13676	13688	1800
1810	13699	13711	13722	13733	13745	13756	13768	13779	13791	13802	1810
1820	13814										1820

**REMARKS**

These tables apply for a reference junction temperature of 0°C.  
 Subtract  $-3 \mu V$  from the values in the tables for a reference junction temperature of 20°C.

**3.2 Standard thermoelectromotive force tables for type R thermocouples**

JIS C1602-1981 (Complying with ANSI MC 96. 1-1975, BS1041-1966 and DIN43710-1977.)

Units :  $\mu V$

Temperature (°C)	0	-1	-2	-3	-4	-5	-6	-7	-8	-9	Temperature (°C)
-50	-226										-50
-40	-188	-192	-196	-200	-204	-207	-211	-215	-219	-223	-40
-30	-145	-150	-154	-158	-163	-167	-171	-175	-180	-184	-30
-20	-100	-105	-109	-114	-119	-123	-128	-132	-137	-141	-20
-10	-51	-56	-61	-66	-71	-76	-81	-86	-91	-95	-10
0	0	-5	-11	-16	-21	-26	-31	-36	-41	-46	0
Temperature (°C)	0	1	2	3	4	5	6	7	8	9	Temperature (°C)
0	0	5	11	16	21	27	32	38	43	49	0
10	54	60	65	71	77	82	88	94	100	105	10
20	111	117	123	129	135	141	147	152	158	165	20
30	171	177	183	189	195	201	207	214	220	226	30
40	232	239	245	251	258	264	271	277	283	290	40
50	296	303	310	316	323	329	336	343	349	356	50
60	363	369	376	383	390	397	403	410	417	424	60
70	431	438	445	452	459	466	473	480	487	494	70
80	501	508	515	523	530	537	544	552	559	566	80
90	573	581	588	595	603	610	617	625	632	640	90
100	647	655	662	670	677	685	692	700	708	715	100
110	723	730	738	746	754	761	769	777	784	792	110
120	800	808	816	824	831	839	847	855	863	871	120
130	879	887	895	903	911	919	927	935	943	951	130
140	959	967	975	983	992	1000	1008	1016	1024	1032	140
150	1041	1049	1057	1065	1074	1082	1090	1099	1107	1115	150
160	1124	1132	1140	1149	1157	1166	1174	1183	1191	1200	160
170	1208	1217	1225	1234	1242	1251	1259	1268	1276	1285	170
180	1294	1302	1311	1319	1328	1337	1345	1354	1363	1372	180
190	1380	1389	1398	1407	1415	1424	1433	1442	1450	1459	190
200	1468	1477	1486	1495	1504	1512	1521	1530	1539	1548	200
210	1557	1566	1575	1584	1593	1602	1611	1620	1629	1638	210
220	1647	1656	1665	1674	1683	1692	1702	1711	1720	1729	220
230	1738	1747	1756	1766	1775	1784	1793	1802	1812	1821	230
240	1830	1839	1849	1858	1867	1876	1886	1895	1904	1914	240
250	1923	1932	1942	1951	1960	1970	1979	1988	1998	2007	250
260	2017	2026	2036	2045	2054	2064	2073	2083	2092	2102	260
270	2111	2121	2130	2140	2149	2159	2169	2178	2188	2197	270
280	2207	2216	2226	2236	2245	2255	2264	2274	2284	2293	280
290	2303	2313	2322	2332	2342	2351	2361	2371	2381	2390	290
300	2400	2410	2420	2429	2439	2449	2459	2468	2478	2488	300
310	2498	2508	2517	2527	2537	2547	2557	2567	2577	2586	310
320	2596	2606	2616	2626	2636	2646	2656	2666	2676	2685	320
330	2695	2705	2715	2725	2735	2745	2755	2765	2775	2785	330
340	2795	2805	2815	2825	2835	2845	2855	2866	2876	2886	340
350	2896	2906	2916	2926	2936	2946	2956	2966	2977	2987	350
360	2997	3007	3017	3027	3037	3048	3058	3068	3078	3088	360
370	3099	3109	3119	3129	3139	3150	3160	3170	3180	3191	370
380	3201	3211	3221	3232	3242	3252	3263	3273	3283	3293	380
390	3304	3314	3324	3335	3345	3355	3366	3376	3386	3397	390

# APPENDICES

**Type R**

JIS C1602-1981 (Complying with ANSI MC 96. 1-1975, BS1041-1966 and DIN43710-1977.)

Units :  $\mu V$

Temperature (°C)	0	1	2	3	4	5	6	7	8	9	Temperature (°C)
400	3407	3418	3428	3438	3449	3459	3470	3480	3490	3501	400
410	3511	3522	3532	3543	3553	3563	3574	3584	3595	3605	410
420	3616	3626	3637	3647	3658	3668	3679	3689	3700	3710	420
430	3721	3731	3742	3752	3763	3774	3784	3795	3805	3816	430
440	3826	3837	3848	3858	3869	3879	3890	3901	3911	3922	440
450	3933	3943	3954	3964	3975	3986	3996	4007	4018	4028	450
460	4039	4050	4061	4071	4082	4093	4103	4114	4125	4136	460
470	4146	4157	4168	4178	4189	4200	4211	4222	4232	4243	470
480	4254	4265	4275	4286	4297	4308	4319	4329	4340	4351	480
490	4362	4373	4384	4394	4405	4416	4427	4438	4449	4460	490
500	4471	4481	4492	4503	4514	4525	4536	4547	4558	4569	500
510	4580	4591	4601	4612	4623	4634	4645	4656	4667	4678	510
520	4689	4700	4711	4722	4733	4744	4755	4766	4777	4788	520
530	4799	4810	4821	4832	4843	4854	4865	4876	4888	4899	530
540	4910	4921	4932	4943	4954	4965	4976	4987	4998	5009	540
550	5021	5032	5043	5054	5065	5076	5087	5099	5110	5121	550
560	5132	5143	5154	5166	5177	5188	5199	5210	5221	5233	560
570	5244	5255	5266	5278	5289	5300	5311	5322	5334	5345	570
580	5356	5368	5379	5390	5401	5413	5424	5435	5446	5458	580
590	5469	5480	5492	5503	5514	5526	5537	5548	5560	5571	590
600	5582	5594	5605	5616	5628	5639	5650	5662	5673	5685	600
610	5696	5707	5719	5730	5742	5753	5764	5776	5787	5799	610
620	5810	5821	5833	5844	5856	5867	5879	5890	5902	5913	620
630	5925	5936	5948	5959	5971	5982	5994	6005	6017	6028	630
640	6040	6051	6063	6074	6086	6098	6109	6121	6132	6144	640
650	6155	6167	6179	6190	6202	6213	6225	6237	6248	6260	650
660	6272	6283	6295	6307	6318	6330	6342	6353	6365	6377	660
670	6388	6400	6412	6423	6435	6447	6458	6470	6482	6494	670
680	6505	6517	6529	6541	6552	6564	6576	6588	6599	6611	680
690	6623	6635	6647	6658	6670	6682	6694	6706	6718	6729	690
700	6741	6753	6765	6777	6789	6800	6812	6824	6836	6848	700
710	6860	6872	6884	6895	6907	6919	6931	6943	6955	6967	710
720	6979	6991	7003	7015	7027	7039	7051	7063	7074	7086	720
730	7098	7110	7122	7134	7146	7158	7170	7182	7194	7206	730
740	7218	7231	7243	7255	7267	7279	7291	7303	7315	7327	740
750	7339	7351	7363	7375	7387	7399	7412	7424	7436	7448	750
760	7460	7472	7484	7496	7509	7521	7533	7545	7557	7569	760
770	7582	7594	7606	7618	7630	7642	7655	7667	7679	7691	770
780	7703	7716	7728	7740	7752	7765	7777	7789	7801	7814	780
790	7826	7838	7850	7863	7875	7887	7900	7912	7924	7937	790
800	7949	7961	7973	7986	7998	8010	8023	8035	8047	8060	800
810	8072	8085	8097	8109	8122	8134	8146	8159	8171	8184	810
820	8196	8208	8221	8233	8246	8258	8271	8283	8295	8308	820
830	8320	8333	8345	8358	8370	8383	8395	8408	8420	8433	830
840	8445	8458	8470	8483	8495	8508	8520	8533	8545	8558	840
850	8570	8583	8595	8608	8621	8633	8646	8658	8671	8683	850
860	8696	8709	8721	8734	8746	8759	8772	8784	8797	8810	860
870	8822	8835	8847	8860	8873	8885	8898	8911	8923	8936	870
880	8949	8961	8974	8987	9000	9012	9025	9038	9050	9063	880
890	9076	9089	9101	9114	9127	9140	9152	9165	9178	9191	890

# APPENDICES

Type R

JIS C1602-1981 (Complying with ANSI MC 96. 1-1975, BS1041-1966 and DIN43710-1977.)

Units :  $\mu V$

Temperature (°C)	0	1	2	3	4	5	6	7	8	9	Temperature (°C)
900	9203	9216	9229	9242	9254	9267	9280	9293	9306	9319	900
910	9331	9344	9357	9370	9383	9395	9408	9421	9434	9447	910
920	9460	9473	9485	9498	9511	9524	9537	9550	9563	9576	920
930	9589	9602	9614	9627	9640	9653	9666	9679	9692	9705	930
940	9718	9731	9744	9757	9770	9783	9796	9809	9822	9835	940
950	9848	9861	9874	9887	9900	9913	9926	9939	9952	9965	950
960	9978	9991	10004	10017	10030	10043	10056	10069	10082	10095	960
970	10109	10122	10135	10148	10161	10174	10187	10200	10213	10227	970
980	10240	10253	10266	10279	10292	10305	10319	10332	10345	10358	980
990	10371	10384	10398	10411	10424	10437	10450	10464	10477	10490	990
1000	10503	10516	10530	10543	10556	10569	10583	10596	10609	10622	1000
1010	10636	10649	10662	10675	10689	10702	10715	10729	10742	10755	1010
1020	10768	10782	10795	10808	10822	10835	10848	10862	10875	10888	1020
1030	10902	10915	10928	10942	10955	10968	10982	10995	11009	11022	1030
1040	11035	11049	11062	11076	11089	11102	11116	11129	11143	11156	1040
1050	11170	11183	11196	11210	11223	11237	11250	11264	11277	11291	1050
1060	11304	11318	11331	11345	11358	11372	11385	11399	11412	11426	1060
1070	11439	11453	11466	11480	11493	11507	11520	11534	11547	11561	1070
1080	11574	11588	11602	11615	11629	11642	11656	11669	11683	11697	1080
1090	11710	11724	11737	11751	11765	11778	11792	11805	11819	11833	1090
1100	11846	11860	11874	11887	11901	11914	11928	11942	11955	11969	1100
1110	11983	11996	12010	12024	12037	12051	12065	12078	12092	12106	1110
1120	12119	12133	12147	12161	12174	12188	12202	12215	12229	12243	1120
1130	12257	12270	12284	12298	12311	12325	12339	12353	12366	12380	1130
1140	12394	12408	12421	12435	12449	12463	12476	12490	12504	12518	1140
1150	12532	12545	12559	12573	12587	12600	12614	12628	12642	12656	1150
1160	12669	12683	12697	12711	12725	12739	12752	12766	12780	12794	1160
1170	12808	12822	12835	12849	12863	12877	12891	12905	12918	12932	1170
1180	12946	12960	12974	12988	13002	13016	13029	13043	13057	13071	1180
1190	13085	13099	13113	13127	13140	13154	13168	13182	13196	13210	1190
1200	13224	13238	13252	13266	13280	13293	13307	13321	13335	13349	1200
1210	13363	13377	13391	13405	13419	13433	13447	13461	13475	13489	1210
1220	13502	13516	13530	13544	13558	13572	13586	13600	13614	13628	1220
1230	13642	13656	13670	13684	13698	13712	13726	13740	13754	13768	1230
1240	13782	13796	13810	13824	13838	13852	13866	13880	13894	13908	1240
1250	13922	13936	13950	13964	13978	13992	14006	14020	14034	14048	1250
1260	14062	14076	14090	14104	14118	14132	14146	14160	14174	14188	1260
1270	14202	14216	14230	14244	14258	14272	14286	14301	14315	14329	1270
1280	14343	14357	14371	14385	14399	14413	14427	14441	14455	14469	1280
1290	14483	14497	14511	14525	14539	14554	14568	14582	14596	14610	1290
1300	14624	14638	14652	14666	14680	14694	14708	14722	14737	14751	1300
1310	14765	14779	14793	14807	14821	14835	14849	14863	14877	14891	1310
1320	14906	14920	14934	14948	14962	14976	14990	15004	15018	15032	1320
1330	15047	15061	15075	15089	15103	15117	15131	15145	15159	15173	1330
1340	15188	15202	15216	15230	15244	15258	15272	15286	15300	15315	1340
1350	15329	15343	15357	15371	15385	15399	15413	15427	15442	15456	1350
1360	15470	15484	15498	15512	15526	15540	15555	15569	15583	15597	1360
1370	15611	15625	15639	15653	15667	15682	15696	15710	15724	15738	1370
1380	15752	15766	15780	15795	15809	15823	15837	15851	15865	15879	1380
1390	15893	15908	15922	15936	15950	15964	15978	15992	16006	16021	1390



# APPENDICES

**Type R**

JIS C1602-1981 (Complying with ANSI MC 96. 1-1975, BS1041-1966 and DIN43710-1977.)

Units :  $\mu V$

Temperature (°C)	0	1	2	3	4	5	6	7	8	9	Temperature (°C)
1400	16035	16049	16063	16077	16091	16105	16119	16134	16148	16162	1400
1410	16176	16190	16204	16218	16232	16247	16261	16275	16289	16303	1410
1420	16317	16331	16345	16360	16374	16388	16402	16416	16430	16444	1420
1430	16458	16472	16487	16501	16515	16529	16543	16557	16571	16585	1430
1440	16599	16614	16628	16642	16656	16670	16684	16698	16712	16726	1440
1450	16741	16755	16769	16783	16797	16811	16825	16839	16853	16867	1450
1460	16882	16896	16910	16924	16938	16952	16966	16980	16994	17008	1460
1470	17022	17037	17051	17065	17079	17093	17107	17121	17135	17149	1470
1480	17163	17177	17192	17206	17220	17234	17248	17262	17276	17290	1480
1490	17304	17318	17332	17346	17360	17374	17388	17403	17417	17431	1490
1500	17445	17459	17473	17487	17501	17515	17529	17543	17557	17571	1500
1510	17585	17599	17613	17627	17641	17655	17669	17684	17698	17712	1510
1520	17726	17740	17754	17768	17782	17796	17810	17824	17838	17852	1520
1530	17866	17880	17894	17908	17922	17936	17950	17964	17978	17992	1530
1540	18006	18020	18034	18048	18062	18076	18090	18104	18118	18132	1540
1550	18146	18160	18174	18188	18202	18216	18230	18244	18258	18272	1550
1560	18286	18299	18313	18327	18341	18355	18369	18383	18397	18411	1560
1570	18425	18439	18453	18467	18481	18495	18509	18523	18537	18550	1570
1580	18564	18578	18592	18606	18620	18634	18648	18662	18676	18690	1580
1590	18703	18717	18731	18745	18759	18773	18787	18801	18815	18828	1590
1600	18842	18856	18870	18884	18898	18912	18926	18939	18953	18967	1600
1610	18981	18995	19009	19023	19036	19050	19064	19078	19092	19106	1610
1620	19119	19133	19147	19161	19175	19188	19202	19216	19230	19244	1620
1630	19257	19271	19285	19299	19313	19326	19340	19354	19368	19382	1630
1640	19395	19409	19423	19437	19450	19464	19478	19492	19505	19519	1640
1650	19533	19547	19560	19574	19588	19602	19615	19629	19643	19656	1650
1660	19670	19684	19698	19711	19725	19739	19752	19766	19780	19793	1660
1670	19807	19821	19834	19848	19862	19875	19889	19903	19916	19930	1670
1680	19944	19957	19971	19985	19998	20012	20025	20039	20053	20066	1680
1690	20080	20093	20107	20120	20134	20148	20161	20175	20188	20202	1690
1700	20215	20229	20242	20256	20269	20283	20296	20309	20323	20336	1700
1710	20350	20363	20377	20390	20403	20417	20430	20443	20457	20470	1710
1720	20483	20497	20510	20523	20537	20550	20563	20576	20590	20603	1720
1730	20616	20629	20642	20656	20669	20682	20695	20708	20721	20734	1730
1740	20748	20761	20774	20787	20800	20813	20826	20839	20852	20865	1740
1750	20878	20891	20904	20916	20929	20942	20955	20968	20981	20994	1750
1760	21006	21019	21032	21045	21057	21070	21083	21096	21108	21121	1760

**REMARKS**

These tables apply for a reference junction temperature of 0°C.  
 Subtract 111  $\mu V$  from the values in the tables for a reference junction temperature of 20°C.

**3.3 Standard thermoelectromotive force tables for type S thermocouples**

JIS C1602-1981 (Complying with ANSI MC 96. 1-1975, BS1041-1966 and DIN43710-1977.)

Units :  $\mu V$

Temperature (°C)	0	-1	-2	-3	-4	-5	-6	-7	-8	-9	Temperature (°C)
-50	-236										-50
-40	-194	-199	-203	-207	-211	-215	-220	-224	-228	-232	-40
-30	-150	-155	-159	-164	-168	-173	-177	-181	-186	-190	-30
-20	-103	-108	-112	-117	-122	-127	-132	-136	-141	-145	-20
-10	-53	-58	-63	-68	-73	-78	-83	-88	-93	-98	-10
0	0	-5	-11	-16	-21	-27	-32	-37	-42	-48	0
Temperature (°C)	0	1	2	3	4	5	6	7	8	9	Temperature (°C)
0	0	5	11	16	22	27	33	38	44	50	0
10	55	61	67	72	78	84	90	95	101	107	10
20	113	119	125	131	137	142	148	154	161	167	20
30	173	179	185	191	197	203	210	216	222	228	30
40	235	241	247	254	260	266	273	279	286	292	40
50	299	305	312	318	325	331	338	345	351	358	50
60	365	371	378	385	391	398	405	412	419	425	60
70	432	439	446	453	460	467	474	481	488	495	70
80	502	509	516	523	530	537	544	551	558	566	80
90	573	580	587	594	602	609	616	623	631	638	90
100	645	653	660	667	675	682	690	697	704	712	100
110	719	727	734	742	749	757	764	772	780	787	110
120	795	802	810	818	825	833	841	848	856	864	120
130	872	879	887	895	903	910	918	926	934	942	130
140	950	957	965	973	981	989	997	1005	1013	1021	140
150	1029	1037	1045	1053	1061	1069	1077	1085	1093	1101	150
160	1109	1117	1125	1133	1141	1149	1158	1166	1174	1182	160
170	1190	1198	1207	1215	1223	1231	1240	1248	1256	1264	170
180	1273	1281	1289	1297	1306	1314	1322	1331	1339	1347	180
190	1356	1364	1373	1381	1389	1398	1406	1415	1423	1432	190
200	1440	1448	1457	1465	1474	1482	1491	1499	1508	1516	200
210	1525	1534	1542	1551	1559	1568	1576	1585	1594	1602	210
220	1611	1620	1628	1637	1645	1654	1663	1671	1680	1689	220
230	1698	1706	1715	1724	1732	1741	1750	1759	1767	1776	230
240	1785	1794	1802	1811	1820	1829	1838	1846	1855	1864	240
250	1873	1882	1891	1899	1908	1917	1926	1935	1944	1953	250
260	1962	1971	1979	1988	1997	2006	2015	2024	2033	2042	260
270	2051	2060	2069	2078	2087	2096	2105	2114	2123	2132	270
280	2141	2150	2159	2168	2177	2186	2195	2204	2213	2222	280
290	2232	2241	2250	2259	2268	2277	2286	2295	2304	2314	290
300	2323	2332	2341	2350	2359	2368	2378	2387	2396	2405	300
310	2414	2424	2433	2442	2451	2460	2470	2479	2488	2497	310
320	2506	2516	2525	2534	2543	2553	2562	2571	2581	2590	320
330	2599	2608	2618	2627	2636	2646	2655	2664	2674	2683	330
340	2692	2702	2711	2720	2730	2739	2748	2758	2767	2776	340
350	2786	2795	2805	2814	2823	2833	2842	2852	2861	2870	350
360	2880	2889	2899	2908	2917	2927	2936	2946	2955	2965	360
370	2974	2984	2993	3003	3012	3022	3031	3041	3050	3059	370
380	3069	3078	3088	3097	3107	3117	3126	3136	3145	3155	380
390	3164	3174	3183	3193	3202	3212	3221	3231	3241	3250	390

# APPENDICES

**Type S**

JIS C1602-1981 (Complying with ANSI MC 96. 1-1975, BS1041-1966 and DIN43710-1977.)

Units :  $\mu V$

Temperature (°C)	0	1	2	3	4	5	6	7	8	9	Temperature (°C)
400	3260	3269	3279	3288	3298	3308	3317	3327	3336	3346	400
410	3356	3365	3375	3384	3394	3404	3413	3423	3433	3442	410
420	3452	3462	3471	3481	3491	3500	3510	3520	3529	3539	420
430	3549	3558	3568	3578	3587	3597	3607	3616	3626	3636	430
440	3645	3655	3665	3675	3684	3694	3704	3714	3723	3733	440
450	3743	3752	3762	3772	3782	3791	3801	3811	3821	3831	450
460	3840	3850	3860	3870	3879	3889	3899	3909	3919	3928	460
470	3938	3948	3958	3968	3977	3987	3997	4007	4017	4027	470
480	4036	4046	4056	4066	4076	4086	4095	4105	4115	4125	480
490	4135	4145	4155	4164	4174	4184	4194	4204	4214	4224	490
500	4234	4243	4253	4263	4273	4283	4293	4303	4313	4323	500
510	4333	4343	4352	4362	4372	4382	4392	4402	4412	4422	510
520	4432	4442	4452	4462	4472	4482	4492	4502	4512	4522	520
530	4532	4542	4552	4562	4572	4582	4592	4602	4612	4622	530
540	4632	4642	4652	4662	4672	4682	4692	4702	4712	4722	540
550	4732	4742	4752	4762	4772	4782	4792	4802	4812	4822	550
560	4832	4842	4852	4862	4873	4883	4893	4903	4913	4923	560
570	4933	4943	4953	4963	4973	4984	4994	5004	5014	5024	570
580	5034	5044	5054	5065	5075	5085	5095	5105	5115	5125	580
590	5136	5146	5156	5166	5176	5186	5197	5207	5217	5227	590
600	5237	5247	5258	5268	5278	5288	5298	5309	5319	5329	600
610	5339	5350	5360	5370	5380	5391	5401	5411	5421	5431	610
620	5442	5452	5462	5473	5483	5493	5503	5514	5524	5534	620
630	5544	5555	5565	5575	5586	5596	5606	5617	5627	5637	630
640	5648	5658	5668	5679	5689	5700	5710	5720	5731	5741	640
650	5751	5762	5772	5782	5793	5803	5814	5824	5834	5845	650
660	5855	5866	5876	5887	5897	5907	5918	5928	5939	5949	660
670	5960	5970	5980	5991	6001	6012	6022	6033	6043	6054	670
680	6064	6075	6085	6096	6106	6117	6127	6138	6148	6159	680
690	6169	6180	6190	6201	6211	6222	6232	6243	6253	6264	690
700	6274	6285	6295	6306	6316	6327	6338	6348	6359	6369	700
710	6380	6390	6401	6412	6422	6433	6443	6454	6465	6475	710
720	6486	6496	6507	6518	6528	6539	6549	6560	6571	6581	720
730	6592	6603	6613	6624	6635	6645	6656	6667	6677	6688	730
740	6699	6709	6720	6731	6741	6752	6763	6773	6784	6795	740
750	6805	6816	6827	6838	6848	6859	6870	6880	6891	6902	750
760	6913	6923	6934	6945	6956	6966	6977	6988	6999	7009	760
770	7020	7031	7042	7053	7063	7074	7085	7096	7107	7117	770
780	7128	7139	7150	7161	7171	7182	7193	7204	7215	7225	780
790	7236	7247	7258	7269	7280	7291	7301	7312	7323	7334	790
800	7345	7356	7367	7377	7388	7399	7410	7421	7432	7443	800
810	7454	7465	7476	7486	7497	7508	7519	7530	7541	7552	810
820	7563	7574	7585	7596	7607	7618	7629	7640	7651	7661	820
830	7672	7683	7694	7705	7716	7727	7738	7749	7760	7771	830
840	7782	7793	7804	7815	7826	7837	7848	7859	7870	7881	840
850	7892	7904	7915	7926	7937	7948	7959	7970	7981	7992	850
860	8003	8014	8025	8036	8047	8058	8069	8081	8092	8103	860
870	8114	8125	8136	8147	8158	8169	8180	8192	8203	8214	870
880	8225	8236	8246	8258	8270	8281	8292	8303	8314	8325	880
890	8336	8348	8359	8370	8381	8392	8404	8415	8426	8437	890

# APPENDICES

**Type S**

JIS C1602-1981 (Complying with ANSI MC 96. 1-1975, BS1041-1966 and DIN43710-1977.)

Units :  $\mu\text{V}$

Temperature (°C)	0	1	2	3	4	5	6	7	8	9	Temperature (°C)
900	8448	8460	8471	8482	8493	8504	8516	8527	8538	8549	900
910	8560	8572	8583	8594	8605	8617	8628	8639	8650	8662	910
920	8673	8684	8695	8707	8718	8729	8741	8752	8763	8774	920
930	8786	8797	8808	8820	8831	8842	8854	8865	8876	8888	930
940	8899	8910	8922	8933	8944	8956	8967	8978	8990	9001	940
950	9012	9024	9035	9047	9058	9069	9081	9092	9103	9115	950
960	9126	9138	9149	9160	9172	9183	9195	9206	9217	9229	960
970	9240	9252	9263	9275	9286	9298	9309	9320	9332	9343	970
980	9355	9366	9378	9389	9401	9412	9424	9435	9447	9458	980
990	9470	9481	9493	9504	9516	9527	9539	9550	9562	9573	990
1000	9585	9596	9608	9619	9631	9642	9654	9665	9677	9689	1000
1010	9700	9712	9723	9735	9746	9758	9770	9781	9793	9804	1010
1020	9816	9828	9839	9851	9862	9874	9886	9897	9909	9920	1020
1030	9932	9944	9955	9967	9979	9990	10002	10013	10025	10037	1030
1040	10048	10060	10072	10083	10095	10107	10118	10130	10142	10154	1040
1050	10165	10177	10189	10200	10212	10224	10235	10247	10259	10271	1050
1060	10282	10294	10306	10318	10329	10341	10353	10364	10376	10388	1060
1070	10400	10411	10423	10435	10447	10459	10470	10482	10494	10506	1070
1080	10517	10529	10541	10553	10565	10576	10588	10600	10612	10624	1080
1090	10635	10647	10659	10671	10683	10694	10706	10718	10730	10742	1090
1100	10754	10765	10777	10789	10801	10813	10825	10836	10848	10860	1100
1110	10872	10884	10896	10908	10919	10931	10943	10955	10967	10979	1110
1120	10991	11003	11014	11026	11038	11050	11062	11074	11086	11098	1120
1130	11110	11121	11133	11145	11157	11169	11181	11193	11205	11217	1130
1140	11229	11241	11252	11264	11276	11288	11300	11312	11324	11336	1140
1150	11348	11360	11372	11384	11396	11408	11420	11432	11443	11455	1150
1160	11467	11479	11491	11503	11515	11527	11539	11551	11563	11575	1160
1170	11587	11599	11611	11623	11635	11647	11659	11671	11683	11695	1170
1180	11707	11719	11731	11743	11755	11767	11779	11791	11803	11815	1180
1190	11827	11839	11851	11863	11875	11887	11899	11911	11923	11935	1190
1200	11947	11959	11971	11983	11995	12007	12019	12031	12043	12055	1200
1210	12067	12079	12091	12103	12116	12128	12140	12152	12164	12176	1210
1220	12188	12200	12212	12224	12236	12248	12260	12272	12284	12296	1220
1230	12308	12320	12332	12345	12357	12369	12381	12393	12405	12417	1230
1240	12429	12441	12453	12465	12477	12489	12501	12514	12526	12538	1240
1250	12550	12562	12574	12586	12598	12610	12622	12634	12647	12659	1250
1260	12671	12683	12695	12707	12719	12731	12743	12755	12767	12780	1260
1270	12792	12804	12816	12828	12840	12852	12864	12876	12888	12901	1270
1280	12913	12925	12937	12949	12961	12973	12985	12997	13010	13022	1280
1290	13034	13046	13058	13070	13082	13094	13107	13119	13131	13143	1290
1300	13155	13167	13179	13191	13203	13216	13228	13240	13252	13264	1300
1310	13276	13288	13300	13313	13325	13337	13349	13361	13373	13385	1310
1320	13397	13410	13422	13434	13446	13458	13470	13482	13495	13507	1320
1330	13519	13531	13543	13555	13567	13579	13592	13604	13616	13628	1330
1340	13640	13652	13664	13677	13689	13701	13713	13725	13737	13749	1340
1350	13761	13774	13786	13798	13810	13822	13834	13846	13859	13871	1350
1360	13883	13895	13907	13919	13931	13943	13956	13968	13980	13992	1360
1370	14004	14016	14028	14040	14053	14065	14077	14089	14101	14113	1370
1380	14125	14138	14150	14162	14174	14186	14198	14210	14222	14235	1380
1390	14247	14259	14271	14283	14295	14307	14319	14332	14344	14356	1390

# APPENDICES

**Type S**

JIS C1602-1981 (Complying with ANSI MC 96. 1-1975, BS1041-1966 and DIN43710-1977.)

Units :  $\mu V$

Temperature (°C)	0	1	2	3	4	5	6	7	8	9	Temperature (°C)
1400	14368	14380	14392	14404	14416	14429	14441	14453	14465	14477	1400
1410	14489	14501	14513	14526	14538	14550	14562	14574	14586	14598	1410
1420	14610	14622	14635	14647	14659	14671	14683	14695	14707	14719	1420
1430	14731	14744	14756	14768	14780	14792	14804	14816	14828	14840	1430
1440	14852	14865	14877	14889	14901	14913	14925	14937	14949	14961	1440
1450	14973	14985	14998	15010	15022	15034	15046	15058	15070	15082	1450
1460	15094	15106	15118	15130	15143	15155	15167	15179	15191	15203	1460
1470	15215	15227	15239	15251	15263	15275	15287	15299	15311	15324	1470
1480	15336	15348	15360	15372	15384	15396	15408	15420	15432	15444	1480
1490	15456	15468	15480	15492	15504	15516	15528	15540	15552	15564	1490
1500	15576	15589	15601	15613	15625	15637	15649	15661	15673	15685	1500
1510	15697	15709	15721	15733	15745	15757	15769	15781	15793	15805	1510
1520	15817	15829	15841	15853	15865	15877	15889	15901	15913	15925	1520
1530	15937	15949	15961	15973	15985	15997	16009	16021	16033	16045	1530
1540	16057	16069	16080	16092	16104	16116	16128	16140	16152	16164	1540
1550	16176	16188	16200	16212	16224	16236	16248	16260	16272	16284	1550
1560	16296	16308	16319	16331	16343	16355	16367	16379	16391	16403	1560
1570	16415	16427	16439	16451	16462	16474	16486	16498	16510	16522	1570
1580	16534	16546	16558	16569	16581	16593	16605	16617	16629	16641	1580
1590	16653	16664	16676	16688	16700	16712	16724	16736	16747	16759	1590
1600	16771	16783	16795	16807	16819	16830	16842	16854	16866	16878	1600
1610	16890	16901	16913	16925	16937	16949	16960	16972	16984	16996	1610
1620	17008	17019	17031	17043	17055	17067	17078	17090	17102	17114	1620
1630	17125	17137	17149	17161	17173	17184	17196	17208	17220	17231	1630
1640	17243	17255	17267	17278	17290	17302	17313	17325	17337	17349	1640
1650	17360	17372	17384	17396	17407	17419	17431	17442	17454	17466	1650
1660	17477	17489	17501	17512	17524	17536	17548	17559	17571	17583	1660
1670	17594	17606	17617	17629	17641	17652	17664	17676	17687	17699	1670
1680	17711	17722	17734	17745	17757	17769	17780	17792	17803	17815	1680
1690	17826	17838	17850	17861	17873	17884	17896	17907	17919	17930	1690
1700	17942	17953	17965	17976	17988	17999	18010	18022	18033	18045	1700
1710	18056	18068	18079	18090	18102	18113	18124	18136	18147	18158	1710
1720	18170	18181	18192	18204	18215	18226	18237	18249	18260	18271	1720
1730	18282	18293	18305	18316	18327	18338	18349	18360	18372	18383	1730
1740	18394	18405	18416	18427	18438	18449	18460	18471	18482	18493	1740
1750	18504	18515	18526	18536	18547	18558	18569	18580	18591	18602	1750
1760	18612	18623	18634	18645	18655	18666	18677	18687	18698	18709	1760

**REMARKS**

These tables apply for a reference junction temperature of 0°C.  
 Subtract  $-3 \mu V$  from the values in the tables for a reference junction temperature of 20°C.

# APPENDICES

Type K

## 3.4 Standard thermoelectromotive force tables for type K thermocouples

JIS C1602-1981 (Complying with ANSI MC 96. 1-1975, BS1041-1966 and DIN43710-1977.)

Units :  $\mu V$

Temperature (°C)	0	-1	-2	-3	-4	-5	-6	-7	-8	-9	Temperature (°C)
-270	-6458										-270
-260	-6441	-6444	-6446	-6448	-6450	-6452	-6453	-6455	-6456	-6457	-260
-250	-6404	-6408	-6413	-6417	-6421	-6425	-6429	-6432	-6435	-6438	-250
-240	-6344	-6351	-6358	-6364	-6371	-6377	-6382	-6388	-6394	-6399	-240
-230	-6262	-6271	-6280	-6289	-6297	-6306	-6314	-6322	-6329	-6337	-230
-220	-6158	-6170	-6181	-6192	-6202	-6213	-6223	-6233	-6243	-6253	-220
-210	-6035	-6048	-6061	-6074	-6087	-6099	-6111	-6123	-6135	-6147	-210
-200	-5891	-5907	-5922	-5936	-5951	-5965	-5980	-5994	-6007	-6021	-200
-190	-5730	-5747	-5763	-5780	-5796	-5813	-5829	-5845	-5860	-5876	-190
-180	-5550	-5569	-5587	-5606	-5624	-5642	-5660	-5678	-5695	-5712	-180
-170	-5354	-5374	-5394	-5414	-5434	-5454	-5474	-5493	-5512	-5531	-170
-160	-5141	-5163	-5185	-5207	-5228	-5249	-5271	-5292	-5313	-5333	-160
-150	-4912	-4936	-4959	-4983	-5006	-5029	-5051	-5074	-5097	-5119	-150
-140	-4669	-4694	-4719	-4743	-4768	-4792	-4817	-4841	-4865	-4889	-140
-130	-4410	-4437	-4463	-4489	-4515	-4541	-4567	-4593	-4618	-4644	-130
-120	-4138	-4166	-4193	-4221	-4248	-4276	-4303	-4330	-4357	-4384	-120
-110	-3852	-3881	-3910	-3939	-3968	-3997	-4025	-4053	-4082	-4110	-110
-100	-3553	-3584	-3614	-3644	-3674	-3704	-3734	-3764	-3793	-3823	-100
-90	-3242	-3274	-3305	-3337	-3368	-3399	-3430	-3461	-3492	-3523	-90
-80	-2920	-2953	-2985	-3018	-3050	-3082	-3115	-3147	-3179	-3211	-80
-70	-2586	-2620	-2654	-2687	-2721	-2754	-2788	-2821	-2854	-2887	-70
-60	-2243	-2277	-2312	-2347	-2381	-2416	-2450	-2484	-2518	-2552	-60
-50	-1889	-1925	-1961	-1996	-2032	-2067	-2102	-2137	-2173	-2208	-50
-40	-1527	-1563	-1600	-1636	-1673	-1709	-1745	-1781	-1817	-1853	-40
-30	-1156	-1193	-1231	-1268	-1305	-1342	-1379	-1416	-1453	-1490	-30
-20	-777	-816	-854	-892	-930	-968	-1005	-1043	-1081	-1118	-20
-10	-392	-431	-469	-508	-547	-585	-624	-662	-701	-739	-10
0	0	-39	-79	-118	-157	-197	-236	-275	-314	-353	0
Temperature (°C)	0	1	2	3	4	5	6	7	8	9	Temperature (°C)
0	0	39	79	119	158	198	238	277	317	357	0
10	397	437	477	517	557	597	637	677	718	758	10
20	798	838	879	919	960	1000	1041	1081	1122	1162	20
30	1203	1244	1285	1325	1366	1407	1448	1489	1529	1570	30
40	1611	1652	1693	1734	1776	1817	1858	1899	1940	1981	40
50	2022	2064	2105	2146	2188	2229	2270	2312	2353	2394	50
60	2436	2477	2519	2560	2601	2643	2684	2726	2767	2809	60
70	2850	2892	2933	2975	3016	3058	3100	3141	3183	3224	70
80	3266	3307	3349	3390	3432	3473	3515	3556	3598	3639	80
90	3681	3722	3764	3805	3847	3888	3930	3971	4012	4054	90
100	4095	4137	4178	4219	4261	4302	4343	4384	4426	4467	100
110	4508	4549	4590	4632	4673	4714	4755	4796	4837	4878	110
120	4919	4960	5001	5042	5083	5124	5164	5205	5246	5287	120
130	5327	5368	5409	5450	5490	5531	5571	5612	5652	5693	130
140	5733	5774	5814	5855	5895	5936	5976	6016	6057	6097	140

# APPENDICES

**Type K**

JIS C1602-1981 (Complying with ANSI MC 96. 1-1975, BS1041-1966 and DIN43710-1977.)

Units :  $\mu V$

Temperature (°C)	0	1	2	3	4	5	6	7	8	9	Temperature (°C)
150	6137	6177	6218	6258	6298	6338	6378	6419	6459	6499	150
160	6539	6579	6619	6659	6699	6739	6779	6819	6859	6899	160
170	6939	6979	7019	7059	7099	7139	7179	7219	7259	7299	170
180	7338	7378	7418	7458	7498	7538	7578	7618	7658	7697	180
190	7737	7777	7817	7857	7897	7937	7977	8017	8057	8097	190
200	8137	8177	8216	8256	8296	8336	8376	8416	8456	8497	200
210	8537	8577	8617	8657	8697	8737	8777	8817	8857	8898	210
220	8938	8978	9018	9058	9099	9139	9179	9220	9260	9300	220
230	9341	9381	9421	9462	9502	9543	9583	9624	9664	9705	230
240	9745	9786	9826	9867	9907	9948	9989	10029	10070	10111	240
250	10151	10192	10233	10274	10315	10355	10396	10437	10478	10519	250
260	10560	10600	10641	10682	10723	10764	10805	10846	10887	10928	260
270	10969	11010	11051	11093	11134	11175	11216	11257	11298	11339	270
280	11381	11422	11463	11504	11546	11587	11628	11669	11711	11752	280
290	11793	11835	11876	11918	11959	12000	12042	12083	12125	12166	290
300	12207	12249	12290	12332	12373	12415	12456	12498	12539	12581	300
310	12623	12664	12706	12747	12789	12831	12872	12914	12955	12997	310
320	13039	13080	13122	13164	13205	13247	13289	13331	13372	13414	320
330	13456	13497	13539	13581	13623	13665	13706	13748	13790	13832	330
340	13874	13915	13957	13999	14041	14083	14125	14167	14208	14250	340
350	14292	14334	14376	14418	14460	14502	14544	14586	14628	14670	350
360	14712	14754	14796	14838	14880	14922	14964	15006	15048	15090	360
370	15132	15174	15216	15258	15300	15342	15384	15426	15468	15510	370
380	15552	15594	15636	15679	15721	15763	15805	15847	15889	15931	380
390	15974	16016	16058	16100	16142	16184	16227	16269	16311	16353	390
400	16395	16438	16480	16522	16564	16607	16649	16691	16733	16776	400
410	16818	16860	16902	16945	16987	17029	17072	17114	17156	17199	410
420	17241	17283	17326	17368	17410	17453	17495	17537	17580	17622	420
430	17664	17707	17749	17792	17834	17876	17919	17961	18004	18046	430
440	18088	18131	18173	18216	18258	18301	18343	18385	18428	18470	440
450	18513	18555	18598	18640	18683	18725	18768	18810	18853	18895	450
460	18938	18980	19023	19065	19108	19150	19193	19235	19278	19320	460
470	19363	19405	19448	19490	19533	19576	19618	19661	19703	19746	470
480	19788	19831	19873	19916	19959	20001	20044	20086	20129	20172	480
490	20214	20257	20299	20342	20385	20427	20470	20512	20555	20598	490
500	20640	20683	20725	20768	20811	20853	20896	20938	20981	21024	500
510	21066	21109	21152	21194	21237	21280	21322	21365	21407	21450	510
520	21493	21535	21578	21621	21663	21706	21749	21791	21834	21876	520
530	21919	21962	22004	22047	22090	22132	22175	22218	22260	22303	530
540	22346	22388	22431	22473	22516	22559	22601	22644	22687	22729	540
550	22772	22815	22857	22900	22942	22985	23028	23070	23113	23156	550
560	23198	23241	23284	23326	23369	23411	23454	23497	23539	23582	560
570	23624	23667	23710	23752	23795	23837	23880	23923	23965	24008	570
580	24050	24093	24136	24178	24221	24263	24306	24348	24391	24434	580
590	24476	24519	24561	24604	24646	24689	24731	24774	24817	24859	590

# APPENDICES

**Type K**

JIS C1602-1981 (Complying with ANSI MC 96. 1-1975, BS1041-1966 and DIN43710-1977.)

Units :  $\mu V$

Temperature (°C)	0	1	2	3	4	5	6	7	8	9	Temperature (°C)
600	24902	24944	24987	25029	25072	25114	25157	25199	25242	25284	600
610	25327	25369	25412	25454	25497	25539	25582	25624	25666	25709	610
620	25751	25794	25836	25879	25921	25964	26006	26048	26091	26133	620
630	26176	26218	26260	26303	26345	26387	26430	26472	26515	26557	630
640	26599	26642	26684	26726	26769	26811	26853	26896	26938	26980	640
650	27022	27065	27107	27149	27192	27234	27276	27318	27361	27403	650
660	27445	27487	27529	27572	27614	27656	27698	27740	27783	27825	660
670	27867	27909	27951	27993	28035	28078	28120	28162	28204	28246	670
680	28288	28330	28372	28414	28456	28498	28540	28583	28625	28667	680
690	28709	28751	28793	28835	28877	28919	28961	29002	29044	29086	690
700	29128	29170	29212	29254	29296	29338	29380	29422	29464	29505	700
710	29547	29589	29631	29673	29715	29756	29798	29840	29882	29924	710
720	29965	30007	30049	30091	30132	30174	30216	30257	30299	30341	720
730	30383	30424	30466	30508	30549	30591	30632	30674	30716	30757	730
740	30799	30840	30882	30924	30965	31007	31048	31090	31131	31173	740
750	31214	31256	31297	31339	31380	31422	31463	31504	31546	31587	750
760	31629	31670	31712	31753	31794	31836	31877	31918	31960	32001	760
770	32042	32084	32125	32166	32207	32249	32290	32331	32372	32414	770
780	32455	32496	32537	32578	32619	32661	32702	32743	32784	32825	780
790	32866	32907	32948	32990	33031	33072	33113	33154	33195	33236	790
800	33277	33318	33359	33400	33441	33482	33523	33564	33604	33645	800
810	33686	33727	33768	33809	33850	33891	33931	33972	34013	34054	810
820	34095	34136	34176	34217	34258	34299	34339	34380	34421	34461	820
830	34502	34543	34583	34624	34665	34705	34746	34787	34827	34868	830
840	34909	34949	34990	35030	35071	35111	35152	35192	35233	35273	840
850	35314	35354	35395	35435	35476	35516	35557	35597	35637	35678	850
860	35718	35758	35799	35839	35880	35920	35960	36000	36041	36081	860
870	36121	36162	36202	36242	36282	36323	36363	36403	36443	36483	870
880	36524	36564	36604	36644	36684	36724	36764	36804	36844	36885	880
890	36925	36965	37005	37045	37085	37125	37165	37205	37245	37285	890
900	37325	37365	37405	37445	37484	37524	37564	37604	37644	37684	900
910	37724	37764	37803	37843	37883	37923	37963	38002	38042	38082	910
920	38122	38162	38201	38241	38281	38320	38360	38400	38439	38479	920
930	38519	38558	38598	38638	38677	38717	38756	38796	38836	38875	930
940	38915	38954	38994	39033	39073	39112	39152	39191	39231	39270	940
950	39310	39349	39388	39428	39467	39507	39546	39585	39625	39664	950
960	39703	39743	39782	39821	39861	39900	39939	39979	40018	40057	960
970	40096	40136	40175	40214	40253	40292	40332	40371	40410	40449	970
980	40488	40527	40566	40605	40645	40684	40723	40762	40801	40840	980
990	40879	40918	40957	40996	41035	41074	41113	41152	41191	41230	990
1000	41269	41308	41347	41385	41424	41463	41502	41541	41580	41619	1000
1010	41657	41696	41735	41774	41813	41851	41890	41929	41968	42006	1010
1020	42045	42084	42123	42161	42200	42239	42277	42316	42355	42393	1020
1030	42432	42470	42509	42548	42586	42625	42663	42702	42740	42779	1030
1040	42817	42856	42894	42933	42971	43010	43048	43087	43125	43164	1040



# APPENDICES

**Type K**

JIS C1602-1981 (Complying with ANSI MC 96. 1-1975, BS1041-1966 and DIN43710-1977.)

Units :  $\mu$  V

Temperature (°C)	0	1	2	3	4	5	6	7	8	9	Temperature (°C)
1050	43202	43240	43279	43317	43356	43394	43432	43471	43509	43547	1050
1060	43585	43624	43662	43700	43739	43777	43815	43853	43891	43930	1060
1070	43968	44006	44044	44082	44121	44159	44197	44235	44273	44311	1070
1080	44349	44387	44425	44463	44501	44539	44577	44615	44653	44691	1080
1090	44729	44767	44805	44843	44881	44919	44957	44995	45033	45070	1090
1100	45108	45146	45184	45222	45260	45297	45335	45373	45411	45448	1100
1110	45486	45524	45561	45599	45637	45675	45712	45750	45787	45825	1110
1120	45863	45900	45938	45975	46013	46051	46088	46126	46163	46201	1120
1130	46238	46275	46313	46350	46388	46425	46463	46500	46537	46575	1130
1140	46612	46649	46687	46724	46761	46799	46836	46873	46910	46948	1140
1150	46985	47022	47059	47096	47134	47171	47208	47245	47282	47319	1150
1160	47356	47393	47430	47468	47505	47542	47579	47616	47653	47689	1160
1170	47726	47763	47800	47837	47874	47911	47948	47985	48021	48058	1170
1180	48095	48132	48169	48205	48242	48279	48316	48352	48389	48426	1180
1190	48462	48499	48536	48572	48609	48645	48682	48718	48755	48792	1190
1200	48828	48865	48901	48937	48974	49010	49047	49083	49120	49156	1200
1210	49192	49229	49265	49301	49338	49374	49410	49446	49483	49519	1210
1220	49555	49591	49627	49663	49700	49736	49772	49808	49844	49880	1220
1230	49916	49952	49988	50024	50060	50096	50132	50168	50204	50240	1230
1240	50276	50311	50347	50383	50419	50455	50491	50526	50562	50598	1240
1250	50633	50669	50705	50741	50776	50812	50847	50883	50919	50954	1250
1260	50990	51025	51061	51096	51132	51167	51203	51238	51274	51309	1260
1270	51344	51380	51415	51450	51486	51521	51556	51592	51627	51662	1270
1280	51697	51733	51768	51803	51838	51873	51908	51943	51979	52014	1280
1290	52049	52084	52119	52154	52189	52224	52259	52294	52329	52364	1290
1300	52398	52433	52468	52503	52538	52573	52608	52642	52677	52712	1300
1310	52747	52781	52816	52851	52886	52920	52955	52989	53024	53059	1310
1320	53093	53128	53162	53197	53232	53266	53301	53335	53370	53404	1320
1330	53439	53473	53507	53542	53576	53611	53645	53679	53714	53748	1330
1340	53782	53817	53851	53885	53920	53954	53988	54022	54057	54091	1340
1350	54125	54159	54193	54228	54262	54296	54330	54364	54398	54432	1350
1360	54466	54501	54535	54569	54603	54637	54671	54705	54739	54773	1360
1370	54807	54841	54875								1370

**REMARKS**

These tables apply for a reference junction temperature of 0°C.  
 Subtract 798  $\mu$  V from the values in the tables for a reference junction temperature of 20°C.

**3.5 Standard thermoelectromotive force tables for type E thermocouples**

JIS C1602-1981 (Complying with ANSI MC 96. 1-1975, BS1041-1966 and DIN43710-1977.)

Units :  $\mu V$

Temperature (°C)	0	-1	-2	-3	-4	-5	-6	-7	-8	-9	Temperature (°C)
-270	-9835										-270
-260	-9797	-9802	-9808	-9813	-9817	-9821	-9825	-9828	-9831	-9833	-260
-250	-9719	-9728	-9737	-9746	-9754	-9762	-9770	-9777	-9784	-9791	-250
-240	-9604	-9617	-9630	-9642	-9654	-9666	-9677	-9688	-9699	-9709	-240
-230	-9455	-9472	-9488	-9503	-9519	-9534	-9549	-9563	-9577	-9591	-230
-220	-9274	-9293	-9313	-9332	-9350	-9368	-9386	-9404	-9421	-9438	-220
-210	-9063	-9085	-9107	-9129	-9151	-9172	-9193	-9214	-9234	-9254	-210
-200	-8824	-8850	-8874	-8899	-8923	-8947	-8971	-8994	-9017	-9040	-200
-190	-8561	-8588	-8615	-8642	-8669	-8696	-8722	-8748	-8774	-8799	-190
-180	-8273	-8303	-8333	-8362	-8391	-8420	-8449	-8477	-8505	-8533	-180
-170	-7963	-7995	-8027	-8058	-8090	-8121	-8152	-8183	-8213	-8243	-170
-160	-7631	-7665	-7699	-7733	-7767	-7800	-7833	-7866	-7898	-7931	-160
-150	-7279	-7315	-7351	-7387	-7422	-7458	-7493	-7528	-7562	-7597	-150
-140	-6907	-6945	-6983	-7020	-7058	-7095	-7132	-7169	-7206	-7243	-140
-130	-6516	-6556	-6596	-6635	-6675	-6714	-6753	-6792	-6830	-6869	-130
-120	-6107	-6149	-6190	-6231	-6273	-6314	-6354	-6395	-6436	-6476	-120
-110	-5680	-5724	-5767	-5810	-5853	-5896	-5938	-5981	-6023	-6065	-110
-100	-5237	-5282	-5327	-5371	-5416	-5460	-5505	-5549	-5593	-5637	-100
-90	-4777	-4824	-4870	-4916	-4963	-5009	-5055	-5100	-5146	-5191	-90
-80	-4301	-4350	-4398	-4446	-4493	-4541	-4588	-4636	-4683	-4730	-80
-70	-3811	-3860	-3910	-3959	-4009	-4058	-4107	-4156	-4204	-4253	-70
-60	-3306	-3357	-3408	-3459	-3509	-3560	-3610	-3661	-3711	-3761	-60
-50	-2787	-2839	-2892	-2944	-2996	-3048	-3100	-3152	-3203	-3254	-50
-40	-2254	-2308	-2362	-2416	-2469	-2522	-2575	-2628	-2681	-2734	-40
-30	-1709	-1764	-1819	-1874	-1929	-1983	-2038	-2092	-2146	-2200	-30
-20	-1151	-1208	-1264	-1320	-1376	-1432	-1487	-1543	-1599	-1654	-20
-10	-581	-639	-696	-754	-811	-868	-925	-982	-1038	-1095	-10
0	0	-59	-117	-176	-234	-292	-350	-408	-466	-524	0
Temperature (°C)	0	1	2	3	4	5	6	7	8	9	Temperature (°C)
0	0	59	118	176	235	295	354	413	472	532	0
10	591	651	711	770	830	890	950	1011	1071	1131	10
20	1192	1252	1313	1373	1434	1495	1556	1617	1678	1739	20
30	1801	1862	1924	1985	2047	2109	2171	2233	2295	2357	30
40	2419	2482	2544	2607	2669	2732	2795	2858	2921	2984	40
50	3047	3110	3173	3237	3300	3364	3428	3491	3555	3619	50
60	3683	3748	3812	3876	3941	4005	4070	4134	4199	4264	60
70	4329	4394	4459	4524	4590	4655	4720	4786	4852	4917	70
80	4983	5049	5115	5181	5247	5314	5380	5446	5513	5579	80
90	5646	5713	5780	5846	5913	5981	6048	6115	6182	6250	90
100	6317	6385	6452	6520	6588	6656	6724	6792	6860	6928	100
110	6996	7064	7133	7201	7270	7339	7407	7476	7545	7614	110
120	7683	7752	7821	7890	7960	8029	8099	8168	8233	8307	120
130	8377	8447	8517	8587	8657	8727	8797	8867	8938	9008	130
140	9078	9149	9220	9290	9361	9432	9503	9573	9644	9715	140
150	9787	9858	9929	10000	10072	10143	10215	10286	10358	10429	150
160	10501	10573	10645	10717	10789	10861	10933	11005	11077	11150	160
170	11222	11294	11367	11439	11512	11585	11657	11730	11803	11876	170
180	11949	12022	12095	12168	12241	12314	12387	12461	12534	12608	180
190	12681	12755	12828	12902	12975	13049	13123	13197	13271	13345	190

# APPENDICES

**Type E**

JIS C1602-1981 (Complying with ANSI MC 96. 1-1975, BS1041-1966 and DIN43710-1977.)

Units :  $\mu V$

Temperature (°C)	0	1	2	3	4	5	6	7	8	9	Temperature (°C)
200	13419	13493	13567	13641	13715	13789	13864	13938	14012	14087	200
210	14161	14236	14310	14385	14460	14534	14609	14684	14759	14834	210
220	14909	14984	15059	15134	15209	15284	15359	15435	15510	15585	220
230	15661	15736	15812	15887	15963	16038	16114	16190	16266	16341	230
240	16417	16493	16569	16645	16721	16797	16873	16949	17025	17101	240
250	17178	17254	17330	17406	17483	17559	17636	17712	17789	17865	250
260	17942	18018	18095	18172	18248	18325	18402	18479	18556	18633	260
270	18710	18787	18864	18941	19018	19095	19172	19249	19326	19404	270
280	19481	19558	19636	19713	19790	19868	19945	20023	20100	20178	280
290	20256	20333	20411	20488	20566	20644	20722	20800	20877	20955	290
300	21033	21111	21189	21267	21345	21423	21501	21579	21657	21735	300
310	21814	21892	21970	22048	22127	22205	22283	22362	22440	22518	310
320	22597	22675	22754	22832	22911	22989	23068	23147	23225	23304	320
330	23383	23461	23540	23619	23698	23777	23855	23934	24013	24092	330
340	24171	24250	24329	24408	24487	24566	24645	24724	24803	24882	340
350	24961	25041	25120	25199	25278	25357	25437	25516	25595	25675	350
360	25754	25833	25913	25992	26072	26151	26230	26310	26389	26469	360
370	26549	26628	26708	26787	26867	26947	27026	27106	27186	27265	370
380	27345	27425	27504	27584	27664	27744	27824	27903	27983	28063	380
390	28143	28223	28303	28383	28463	28543	28623	28703	28783	28863	390
400	28943	29023	29103	29183	29263	29343	29423	29503	29584	29664	400
410	29744	29824	29904	29984	30065	30145	30225	30305	30386	30466	410
420	30546	30627	30707	30787	30868	30948	31028	31109	31189	31270	420
430	31350	31430	31511	31591	31672	31752	31833	31913	31994	32074	430
440	32155	32235	32316	32396	32477	32557	32638	32719	32799	32880	440
450	32960	33041	33122	33202	33283	33364	33444	33525	33605	33686	450
460	33767	33848	33928	34009	34090	34170	34251	34332	34413	34493	460
470	34574	34655	34736	34816	34897	34978	35059	35140	35220	35301	470
480	35382	35463	35544	35624	35705	35786	35867	35948	36029	36109	480
490	36190	36271	36352	36433	36514	36595	36675	36756	36837	36918	490
500	36999	37080	37161	37242	37323	37403	37484	37565	37646	37727	500
510	37808	37889	37970	38051	38132	38213	38293	38374	38455	38536	510
520	38617	38698	38779	38860	38941	39022	39103	39184	39264	39345	520
530	39426	39507	39588	39669	39750	39831	39912	39993	40074	40155	530
540	40236	40316	40397	40478	40559	40640	40721	40802	40883	40964	540
550	41045	41125	41206	41287	41368	41449	41530	41611	41692	41773	550
560	41853	41934	42015	42096	42177	42258	42339	42419	42500	42581	560
570	42662	42743	42824	42904	42985	43066	43147	43228	43308	43389	570
580	43470	43551	43632	43712	43793	43874	43955	44035	44116	44197	580
590	44278	44358	44439	44520	44601	44681	44762	44843	44923	45004	590
600	45085	45165	45246	45327	45407	45488	45569	45649	45730	45811	600
610	45891	45972	46052	46133	46213	46294	46375	46455	46536	46616	610
620	46697	46777	46858	46938	47019	47099	47180	47260	47341	47421	620
630	47502	47582	47663	47743	47824	47904	47984	48065	48145	48226	630
640	48306	48386	48467	48547	48627	48708	48788	48868	48949	49029	640
650	49109	49189	49270	49350	49430	49510	49591	49671	49751	49831	650
660	49911	49992	50072	50152	50232	50312	50392	50472	50553	50633	660
670	50713	50793	50873	50953	51033	51113	51193	51273	51353	51433	670
680	51513	51593	51673	51753	51833	51913	51993	52073	52152	52232	680
690	52312	52392	52472	52552	52632	52711	52791	52871	52951	53031	690

# APPENDICES

## Type E

JIS C1602-1981 (Complying with ANSI MC 96. 1-1975, BS1041-1966 and DIN43710-1977.)

Units :  $\mu\text{V}$

Temperature (°C)	0	1	2	3	4	5	6	7	8	9	Temperature (°C)
700	53110	53190	53270	53350	53429	53509	53589	53668	53748	53828	700
710	53907	53987	54066	54146	54226	54305	54385	54464	54544	54623	710
720	54703	54782	54862	54941	55021	55100	55180	55259	55339	55418	720
730	55498	55577	55656	55736	55815	55894	55974	56053	56132	56212	730
740	56291	56370	56449	56529	56608	56687	56766	56845	56924	57004	740
750	57083	57162	57241	57320	57399	57478	57557	57636	57715	57794	750
760	57873	57952	58031	58110	58189	58268	58347	58426	58505	58584	760
770	58663	58742	58820	58899	58978	59057	59136	59214	59293	59372	770
780	59451	59529	59608	59687	59765	59844	59923	60001	60080	60159	780
790	60237	60316	60394	60473	60551	60630	60708	60787	60865	60944	790
800	61022	61101	61179	61258	61336	61414	61493	61571	61649	61728	800
810	61806	61884	61962	62041	62119	62197	62275	62353	62432	62510	810
820	62588	62666	62744	62822	62900	62978	63056	63134	63212	63290	820
830	63368	63446	63524	63602	63680	63758	63836	63914	63992	64069	830
840	64147	64225	64303	64380	64458	64536	64614	64691	64769	64847	840
850	64924	65002	65080	65157	65235	65312	65390	65467	65545	65622	850
860	65700	65777	65855	65932	66009	66087	66164	66241	66319	66396	860
870	66473	66551	66628	66705	66782	66859	66937	67014	67091	67168	870
880	67245	67322	67399	67476	67553	67630	67707	67784	67861	67938	880
890	68015	68092	68169	68246	68323	68399	68476	68553	68630	68706	890
900	68783	68860	68936	69013	69090	69166	69243	69320	69396	69473	900
910	69549	69626	69702	69779	69855	69931	70008	70084	70161	70237	910
920	70313	70390	70466	70542	70618	70694	70771	70847	70923	70999	920
930	71075	71151	71227	71304	71380	71456	71532	71608	71683	71759	930
940	71835	71911	71987	72063	72139	72215	72290	72366	72442	72518	940
950	72593	72669	72745	72820	72896	72972	73047	73123	73199	73274	950
960	73350	73425	73501	73576	73652	73727	73802	73878	73953	74029	960
970	74104	74179	74255	74330	74405	74480	74556	74631	74706	74781	970
980	74857	74932	75007	75082	75157	75232	75307	75382	75458	75533	980
990	75608	75683	75758	75833	75908	75983	76058	76133	76208	76283	990
1000	76358										1000

### REMARKS

These tables apply for a reference junction temperature of 0°C.

Subtract  $-3 \mu\text{V}$  from the values in the tables for a reference junction temperature of 20°C.

# APPENDICES

Type J

## 3.6 Standard thermoelectromotive force tables for type J thermocouples

JIS C1602-1981 (Complying with ANSI MC 96. 1-1975, BS1041-1966 and DIN43710-1977.)

Units :  $\mu\text{V}$

Temperature (°C)	0	-1	-2	-3	-4	-5	-6	-7	-8	-9	Temperature (°C)
-210	-8096										-210
-200	-7890	-7912	-7934	-7955	-7976	-7996	-8017	-8037	-8057	-8076	-200
-190	-7659	-7683	-7707	-7731	-7755	-7778	-7801	-7824	-7846	-7868	-190
-180	-7402	-7429	-7455	-7482	-7508	-7533	-7559	-7584	-7609	-7634	-180
-170	-7122	-7151	-7180	-7209	-7237	-7265	-7293	-7321	-7348	-7375	-170
-160	-6821	-6852	-6883	-6914	-6944	-6974	-7004	-7034	-7064	-7093	-160
-150	-6499	-6532	-6565	-6598	-6630	-6663	-6695	-6727	-6758	-6790	-150
-140	-6159	-6194	-6228	-6263	-6297	-6331	-6365	-6399	-6433	-6466	-140
-130	-5801	-5837	-5874	-5910	-5946	-5982	-6018	-6053	-6089	-6124	-130
-120	-5426	-5464	-5502	-5540	-5578	-5615	-5653	-5690	-5727	-5764	-120
-110	-5036	-5076	-5115	-5155	-5194	-5233	-5272	-5311	-5349	-5388	-110
-100	-4632	-4673	-4714	-4755	-4795	-4836	-4876	-4916	-4956	-4996	-100
-90	-4215	-4257	-4299	-4341	-4383	-4425	-4467	-4508	-4550	-4591	-90
-80	-3785	-3829	-3872	-3915	-3958	-4001	-4044	-4087	-4130	-4172	-80
-70	-3344	-3389	-3433	-3478	-3522	-3566	-3610	-3654	-3698	-3742	-70
-60	-2892	-2938	-2984	-3029	-3074	-3120	-3165	-3210	-3255	-3299	-60
-50	-2431	-2478	-2524	-2570	-2617	-2663	-2709	-2755	-2801	-2847	-50
-40	-1960	-2008	-2055	-2102	-2150	-2197	-2244	-2291	-2338	-2384	-40
-30	-1481	-1530	-1578	-1626	-1674	-1722	-1770	-1818	-1865	-1913	-30
-20	-995	-1044	-1093	-1141	-1190	-1239	-1288	-1336	-1385	-1433	-20
-10	-501	-550	-600	-650	-699	-748	-798	-847	-896	-945	-10
0	0	-50	-101	-151	-201	-251	-301	-351	-401	-451	0
Temperature (°C)	0	1	2	3	4	5	6	7	8	9	Temperature (°C)
0	0	50	101	151	202	253	303	354	405	456	0
10	507	558	609	660	711	762	813	865	916	967	10
20	1019	1070	1122	1174	1225	1277	1329	1381	1432	1484	20
30	1536	1588	1640	1693	1745	1797	1849	1901	1954	2006	30
40	2058	2111	2163	2216	2268	2321	2374	2426	2479	2532	40
50	2585	2638	2691	2743	2796	2849	2902	2956	3009	3062	50
60	3115	3168	3221	3275	3328	3381	3435	3488	3542	3595	60
70	3649	3702	3756	3809	3863	3917	3971	4024	4078	4132	70
80	4186	4239	4293	4347	4401	4455	4509	4563	4617	4671	80
90	4725	4780	4834	4888	4942	4996	5050	5105	5159	5213	90
100	5268	5322	5376	5431	5485	5540	5594	5649	5703	5758	100
110	5812	5867	5921	5976	6031	6085	6140	6195	6249	6304	110
120	6359	6414	6468	6523	6578	6633	6688	6742	6797	6852	120
130	6907	6962	7017	7072	7127	7182	7237	7292	7347	7402	130
140	7457	7512	7567	7622	7677	7732	7787	7843	7898	7953	140
150	8008	8063	8118	8174	8229	8284	8339	8394	8450	8505	150
160	8560	8616	8671	8726	8781	8837	8892	8947	9003	9058	160
170	9113	9169	9224	9279	9335	9390	9446	9501	9556	9612	170
180	9667	9723	9778	9834	9889	9944	10000	10055	10111	10166	180
190	10222	10277	10333	10388	10444	10499	10555	10610	10666	10721	190

# APPENDICES

## Type J

JIS C1602-1981 (Complying with ANSI MC 96. 1-1975, BS1041-1966 and DIN43710-1977.)

Units :  $\mu V$

Temperature (°C)	0	1	2	3	4	5	6	7	8	9	Temperature (°C)
200	10777	10832	10888	10943	10999	11054	11110	11165	11221	11276	200
210	11332	11387	11443	11498	11554	11609	11665	11720	11776	11831	210
220	11887	11943	11998	12054	12109	12165	12220	12276	12331	12387	220
230	12442	12498	12553	12609	12664	12720	12776	12831	12887	12942	230
240	12998	13053	13109	13164	13220	13275	13331	13386	13442	13497	240
250	13553	13608	13664	13719	13775	13830	13886	13941	13997	14052	250
260	14108	14163	14219	14274	14330	14385	14441	14496	14552	14607	260
270	14663	14718	14774	14829	14885	14940	14995	15051	15106	15162	270
280	15217	15273	15328	15383	15439	15494	15550	15605	15661	15716	280
290	15771	15827	15882	15938	15993	16048	16104	16159	16214	16270	290
300	16325	16380	16436	16491	16547	16602	16657	16713	16768	16823	300
310	16879	16934	16989	17044	17100	17155	17210	17266	17321	17376	310
320	17432	17487	17542	17597	17653	17708	17763	17818	17874	17929	320
330	17984	18039	18095	18150	18205	18260	18316	18371	18426	18481	330
340	18537	18592	18647	18702	18757	18813	18868	18923	18978	19033	340
350	19089	19144	19199	19254	19309	19364	19420	19475	19530	19585	350
360	19640	19695	19751	19806	19861	19916	19971	20026	20081	20137	360
370	20192	20247	20302	20357	20412	20467	20523	20578	20633	20688	370
380	20743	20798	20853	20909	20964	21019	21074	21129	21184	21239	380
390	21295	21350	21405	21460	21515	21570	21625	21680	21736	21791	390
400	21846	21901	21956	22011	22066	22122	22177	22232	22287	22342	400
410	22397	22453	22508	22563	22618	22673	22728	22784	22839	22894	410
420	22949	23004	23060	23115	23170	23225	23280	23336	23391	23446	420
430	23501	23556	23612	23667	23722	23777	23833	23888	23943	23999	430
440	24054	24109	24164	24220	24275	24330	24386	24441	24496	24552	440
450	24607	24662	24718	24773	24829	24884	24939	24995	25050	25106	450
460	25161	25217	25272	25327	25383	25438	25494	25549	25605	25661	460
470	25716	25772	25827	25883	25938	25994	26050	26105	26161	26216	470
480	26272	26328	26383	26439	26495	26551	26606	26662	26718	26774	480
490	26829	26885	26941	26997	27053	27109	27165	27220	27276	27332	490
500	27388	27444	27500	27556	27612	27668	27724	27780	27836	27893	500
510	27949	28005	28061	28117	28173	28230	28286	28342	28398	28455	510
520	28511	28567	28624	28680	28736	28793	28849	28906	28962	29019	520
530	29075	29132	29188	29245	29301	29358	29415	29471	29528	29585	530
540	29642	29698	29755	29812	29869	29926	29983	30039	30096	30153	540
550	30210	30267	30324	30381	30439	30496	30553	30610	30667	30724	550
560	30782	30839	30896	30954	31011	31068	31126	31183	31241	31298	560
570	31356	31413	31471	31528	31586	31644	31702	31759	31817	31875	570
580	31933	31991	32048	32106	32164	32222	32280	32338	32396	32455	580
590	32513	32571	32629	32687	32746	32804	32862	32921	32979	33038	590
600	33096	33155	33213	33272	33330	33389	33448	33506	33565	33624	600
610	33683	33742	33800	33859	33918	33977	34036	34095	34155	34214	610
620	34273	34332	34391	34451	34510	34569	34629	34688	34748	34807	620
630	34867	34926	34986	35046	35105	35165	35225	35285	35344	35404	630
640	35464	35524	35584	35644	35704	35764	35825	35885	35945	36005	640

# APPENDICES

**Type J**

JIS C1602-1981 (Complying with ANSI MC 96. 1-1975, BS1041-1966 and DIN43710-1977.)

Units :  $\mu V$

Temperature (°C)	0	1	2	3	4	5	6	7	8	9	Temperature (°C)
650	36066	36126	36186	36247	36307	36368	36428	36489	36549	36610	650
660	36671	36732	36792	36853	36914	36975	37036	37097	37158	37219	660
670	37280	37341	37402	37463	37525	37586	37647	37709	37770	37831	670
680	37893	37954	38016	38078	38139	38201	38262	38324	38386	38448	680
690	38510	38572	38633	38695	38757	38819	38882	38944	39006	39068	690
700	39130	39192	39255	39317	39379	39442	39504	39567	39629	39692	700
710	39754	39817	39880	39942	40005	40068	40131	40193	40256	40319	710
720	40382	40445	40508	40571	40634	40697	40760	40823	40886	40950	720
730	41013	41076	41139	41203	41266	41329	41393	41456	41520	41583	730
740	41647	41710	41774	41837	41901	41965	42028	42092	42156	42219	740
750	42283	42347	42411	42475	42538	42602	42666	42730	42794	42858	750
760	42922	42986	43050	43114	43178	43242	43306	43370	43435	43499	760
770	43563	43627	43692	43756	43820	43885	43949	44014	44078	44142	770
780	44207	44271	44336	44400	44465	44529	44594	44658	44723	44788	780
790	44852	44917	44981	45046	45111	45175	45240	45304	45369	45434	790
800	45498	45563	45627	45692	45757	45821	45886	45950	46015	46080	800
810	46144	46209	46273	46338	46403	46467	46532	46596	46661	46725	810
820	46790	46854	46919	46983	47047	47112	47176	47241	47305	47369	820
830	47434	47498	47562	47627	47691	47755	47819	47884	47948	48012	830
840	48076	48140	48204	48269	48333	48397	48461	48525	48589	48653	840
850	48716	48780	48844	48908	48972	49036	49099	49163	49227	49291	850
860	49354	49418	49481	49545	49608	49672	49735	49799	49862	49926	860
870	49989	50052	50116	50179	50242	50305	50369	50432	50495	50558	870
880	50621	50684	50747	50810	50873	50936	50998	51061	51124	51187	880
890	51249	51312	51375	51437	51500	51562	51625	51687	51750	51812	890
900	51875	51937	51999	52061	52124	52186	52248	22310	52372	52434	900
910	52496	52558	52620	52682	52744	52806	52868	52929	52991	53053	910
920	53115	53176	53238	53299	53361	53422	53484	53545	53607	53668	920
930	53729	53791	53852	53913	53974	54035	54096	54157	54219	54280	930
940	54341	54401	54462	54523	54584	54645	54706	54766	54827	54888	940
950	54948	55009	55070	55130	55191	55251	55312	55372	55432	55493	950
960	55553	55613	55674	55734	55794	55854	55914	55974	56035	56095	960
970	56155	56215	56275	56334	56394	56454	56514	56574	56634	56693	970
980	56753	56813	56873	56932	56992	57051	57111	57170	57230	57289	980
990	57349	57408	57468	57527	57586	57646	57705	57764	57824	57883	990
1000	57942	58001	58060	58120	58179	58238	58297	58356	58415	58474	1000
1010	58533	58592	58651	58710	58769	58827	58886	58945	59004	59063	1010
1020	59121	59180	59239	59298	59356	59415	59474	59532	59591	59650	1020
1030	59708	59767	59825	59884	59942	60001	60059	60118	60176	60235	1030
1040	60293	60351	60410	60468	60527	60585	60643	60702	60760	60818	1040
1050	60876	60935	60993	61051	61109	61168	61226	61284	61342	61400	1050
1060	61459	61517	61575	61633	61691	61749	61807	61865	61923	61981	1060
1070	62039	62097	62156	62214	62272	62330	62388	62446	62504	62562	1070
1080	62619	62677	62735	62793	62851	62909	62967	63025	63083	63141	1080
1090	63199	63257	63314	63372	63430	63488	63546	63604	63662	63719	1090

# APPENDICES

## Type J

JIS C1602-1981 (Complying with ANSI MC 96. 1-1975, BS1041-1966 and DIN43710-1977.)

Units :  $\mu\text{V}$

Temperature (°C)	0	1	2	3	4	5	6	7	8	9	Temperature (°C)
1100	63777	63835	63893	63951	64009	64066	64124	64182	64240	64298	1100
1110	64355	64413	64471	64529	64586	64644	64702	64760	64817	64875	1110
1120	64933	64991	65048	65106	65164	65222	65279	65337	65395	65453	1120
1130	65510	65568	65626	65683	65741	65799	65856	65914	65972	66029	1130
1140	66087	66145	66202	66260	66318	66375	66433	66491	66548	66606	1140
1150	66664	66721	66779	66836	66894	66952	67009	67067	67124	67182	1150
1160	67240	67297	67355	67412	67470	67527	67585	67643	67700	67758	1160
1170	67815	67873	67930	67988	68045	68103	68160	68217	68275	68332	1170
1180	68390	68447	68505	68562	68619	68677	68734	68792	68849	68906	1180
1190	68964	69021	69078	69135	69193	69250	69307	69364	69422	69479	1190
1200	69536										1200

### REMARKS

These tables apply for a reference junction temperature of 0°C.  
 Subtract  $1019\mu\text{V}$  from the values in the tables for a reference junction temperature of 20°C.



**3.7 Standard thermoelectromotive force tables for type T thermocouples**

JIS C1602-1981 (Complying with ANSI MC 96. 1-1975, BS1041-1966 and DIN43710-1977.)

Units :  $\mu V$

Temperature (°C)	0	-1	-2	-3	-4	-5	-6	-7	-8	-9	Temperature (°C)
-270	-6258										-270
-260	-6232	-6236	-6239	-6242	-6245	-6248	-6251	-6253	-6255	-6256	-260
-250	-6181	-6187	-6193	-6198	-6204	-6209	-6214	-6219	-6224	-6228	-250
-240	-6105	-6114	-6122	-6130	-6138	-6146	-6153	-6160	-6167	-6174	-240
-230	-6007	-6018	-6028	-6039	-6049	-6059	-6068	-6078	-6087	-6096	-230
-220	-5889	-5901	-5914	-5926	-5938	-5950	-5962	-5973	-5985	-5996	-220
-210	-5753	-5767	-5782	-5795	-5809	-5823	-5836	-5850	-5863	-5876	-210
-200	-5603	-5619	-5634	-5650	-5665	-5680	-5695	-5710	-5724	-5739	-200
-190	-5439	-5456	-5473	-5489	-5506	-5522	-5539	-5555	-5571	-5587	-190
-180	-5261	-5279	-5297	-5315	-5333	-5351	-5369	-5387	-5404	-5421	-180
-170	-5069	-5089	-5109	-5128	-5147	-5167	-5186	-5205	-5223	-5242	-170
-160	-4865	-4886	-4907	-4928	-4948	-4969	-4989	-5010	-5030	-5050	-160
-150	-4648	-4670	-4693	-4715	-4737	-4758	-4780	-4801	-4823	-4844	-150
-140	-4419	-4442	-4466	-4489	-4512	-4535	-4558	-4581	-4603	-4626	-140
-130	-4177	-4202	-4226	-4251	-4275	-4299	-4323	-4347	-4371	-4395	-130
-120	-3923	-3949	-3974	-4000	-4026	-4051	-4077	-4102	-4127	-4152	-120
-110	-3656	-3684	-3711	-3737	-3764	-3791	-3818	-3844	-3870	-3897	-110
-100	-3378	-3407	-3435	-3463	-3491	-3519	-3547	-3574	-3602	-3629	-100
-90	-3089	-3118	-3147	-3177	-3206	-3235	-3264	-3293	-3321	-3350	-90
-80	-2788	-2818	-2849	-2879	-2909	-2939	-2970	-2999	-3029	-3059	-80
-70	-2475	-2507	-2539	-2570	-2602	-2633	-2664	-2695	-2726	-2757	-70
-60	-2152	-2185	-2218	-2250	-2283	-2315	-2348	-2380	-2412	-2444	-60
-50	-1819	-1853	-1886	-1920	-1953	-1987	-2020	-2053	-2087	-2120	-50
-40	-1475	-1510	-1544	-1579	-1614	-1648	-1682	-1717	-1751	-1785	-40
-30	-1121	-1157	-1192	-1228	-1263	-1299	-1334	-1370	-1405	-1440	-30
-20	-757	-794	-830	-867	-903	-940	-976	-1013	-1049	-1085	-20
-10	-383	-421	-458	-496	-534	-571	-608	-646	-683	-720	-10
0	0	-39	-77	-116	-154	-193	-231	-269	-307	-345	0
Temperature (°C)	0	1	2	3	4	5	6	7	8	9	Temperature (°C)
0	0	39	78	117	156	195	234	273	312	351	0
10	391	430	470	510	549	589	629	669	709	749	10
20	789	830	870	911	951	992	1032	1073	1114	1155	20
30	1196	1237	1279	1320	1361	1403	1444	1486	1528	1569	30
40	1611	1653	1695	1738	1780	1822	1865	1907	1950	1992	40
50	2035	2078	2121	2164	2207	2250	2294	2337	2380	2424	50
60	2467	2511	2555	2599	2643	2687	2731	2775	2819	2864	60
70	2908	2953	2997	3042	3087	3131	3176	3221	3266	3312	70
80	3357	3402	3447	3493	3538	3584	3630	3676	3721	3767	80
90	3813	3859	3906	3952	3998	4044	4091	4137	4184	4231	90
100	4277	4324	4371	4418	4465	4512	4559	4607	4654	4701	100
110	4749	4796	4844	4891	4939	4987	5035	5083	5131	5179	110
120	5227	5275	5324	5372	5420	5469	5517	5566	5615	5663	120
130	5712	5761	5810	5859	5908	5957	6007	6056	6105	6155	130
140	6204	6254	6303	6353	6403	6452	6502	6552	6602	6652	140
150	6702	6753	6803	6853	6903	6954	7004	7055	7106	7156	150
160	7207	7258	7309	7360	7411	7462	7513	7564	7615	7666	160
170	7718	7769	7821	7872	7924	7975	8027	8079	8131	8183	170
180	8235	8287	8339	8391	8443	8495	8548	8600	8652	8705	180
190	8757	8810	8863	8915	8968	9021	9074	9127	9180	9233	190

# APPENDICES

## Type T

JIS C1602-1981 (Complying with ANSI MC 96. 1-1975, BS1041-1966 and DIN43710-1977.)

Units :  $\mu V$

Temperature (°C)	0	1	2	3	4	5	6	7	8	9	Temperature (°C)
200	9286	9339	9392	9446	9499	9553	9606	9659	9713	9767	200
210	9820	9874	9928	9982	10036	10090	10114	10198	10252	10306	210
220	10360	10414	10469	10523	10578	10632	10687	10741	10796	10851	220
230	10905	10960	11015	11070	11125	11180	11235	11290	11345	11401	230
240	11456	11511	11566	11622	11677	11733	11788	11844	11900	11956	240
250	12011	12067	12123	12179	12235	12291	12347	12403	12459	12515	250
260	12572	12628	12684	12741	12797	12854	12910	12967	13024	13080	260
270	13137	13194	13251	13307	13364	13421	13478	13535	13592	13650	270
280	13707	13764	13821	13879	13936	13993	14051	14108	14166	14223	280
290	14281	14339	14396	14454	14512	14570	14628	14686	14744	14802	290
300	14860	14918	14976	15034	15092	15151	15209	15267	15326	15384	300
310	15443	15501	15560	15619	15677	15736	15795	15853	15912	15971	310
320	16030	16089	16148	16207	16266	16325	16384	16444	16503	16562	320
330	16621	16681	16740	16800	16859	16919	16978	17038	17097	17157	330
340	17217	17277	17336	17396	17456	17516	17576	17636	17696	17756	340
350	17816	17877	17937	17997	18057	18118	18178	18238	18299	18359	350
360	18420	18480	18541	18602	18662	18723	18784	18845	18905	18966	360
370	19027	19088	19149	19210	19271	19332	19393	19455	19516	19577	370
380	19638	19699	19761	19822	19883	19945	20006	20068	20129	20191	380
390	20252	20314	20376	20437	20499	20560	20622	20684	20746	20807	390
400	20869										400

### REMARKS

These tables apply for a reference junction temperature of 0°C.

Subtract 789  $\mu V$  from the values in the tables for a reference junction temperature of 20°C.

**3.8 Standard thermoelectromotive force tables for type Fe-CuNi thermocouples**

DIN43710-1977

Units : mV

Temperature (°C)	0	1	2	3	4	5	6	7	8	9	Temperature (°C)
-200	-8.15	-	-	-	-	-	-	-	-	-	-200
-190	-7.86	-7.89	-7.92	-7.95	-7.98	-8.00	-8.03	-8.06	-8.09	-8.12	-190
-180	-7.56	-7.59	-7.62	-7.65	-7.68	-7.71	-7.74	-7.77	-7.80	-7.83	-180
-170	-7.25	-7.28	-7.31	-7.34	-7.37	-7.40	-7.44	-7.47	-7.50	-7.53	-170
-160	-6.93	-6.96	-6.99	-7.03	-7.06	-7.09	-7.12	-7.15	-7.19	-7.22	-160
-150	-6.60	-6.63	-6.66	-6.70	-6.73	-6.76	-6.80	-6.83	-6.86	-6.90	-150
-140	-6.26	-6.29	-6.33	-6.36	-6.39	-6.43	-6.46	-6.50	-6.53	-6.56	-140
-130	-5.90	-5.93	-5.97	-6.01	-6.04	-6.08	-6.11	-6.15	-6.19	-6.22	-130
-120	-5.53	-5.57	-5.60	-5.64	-5.68	-5.71	-5.75	-5.79	-5.82	-5.86	-120
-110	-5.15	-5.19	-5.22	-5.26	-5.30	-5.34	-5.38	-5.41	-5.45	-5.49	-110
-100	-4.75	-4.79	-4.83	-4.87	-4.91	-4.95	-4.99	-5.03	-5.07	-5.11	-100
-90	-4.33	-4.37	-4.41	-4.45	-4.50	-4.54	-4.58	-4.62	-4.66	-4.71	-90
-80	-3.89	-3.93	-3.98	-4.02	-4.06	-4.11	-4.15	-4.20	-4.24	-4.28	-80
-70	-3.44	-3.48	-3.53	-3.57	-3.62	-3.66	-3.71	-3.75	-3.80	-3.84	-70
-60	-2.98	-3.02	-3.07	-3.12	-3.16	-3.21	-3.25	-3.30	-3.35	-3.39	-60
-50	-2.51	-2.56	-2.60	-2.65	-2.70	-2.74	-2.79	-2.84	-2.88	-2.93	-50
-40	-2.03	-2.08	-2.12	-2.17	-2.22	-2.27	-2.32	-2.36	-2.41	-2.46	-40
-30	-1.53	-1.58	-1.63	-1.68	-1.73	-1.78	-1.83	-1.88	-1.93	-1.98	-30
-20	-1.02	-1.07	-1.12	-1.17	-1.22	-1.27	-1.32	-1.38	-1.43	-1.48	-20
-10	-0.51	-0.56	-0.61	-0.66	-0.71	-0.76	-0.81	-0.87	-0.92	-0.97	-10
-0	0.00	-0.05	-0.10	-0.15	-0.20	-0.25	-0.31	-0.36	-0.41	-0.46	-0
0	0.00	0.05	0.10	0.16	0.21	0.26	0.31	0.36	0.42	0.47	0
10	0.52	0.57	0.63	0.68	0.73	0.78	0.84	0.89	0.94	1.00	10
20	1.05	1.10	1.16	1.21	1.26	1.31	1.37	1.42	1.47	1.53	20
30	1.58	1.63	1.69	1.74	1.79	1.84	1.90	1.95	2.00	2.06	30
40	2.11	2.16	2.22	2.27	2.33	2.38	2.43	2.49	2.54	2.60	40
50	2.65	2.70	2.76	2.81	2.87	2.92	2.97	3.03	3.08	3.14	50
60	3.19	3.24	3.30	3.35	3.41	3.46	3.51	3.57	3.62	3.68	60
70	3.73	3.78	3.84	3.89	3.95	4.00	4.05	4.11	4.16	4.22	70
80	4.27	4.32	4.38	4.43	4.49	4.54	4.60	4.65	4.71	4.77	80
90	4.82	4.87	4.93	4.98	5.04	5.09	5.15	5.20	5.26	5.32	90
100	5.37	5.42	5.48	5.53	5.59	5.64	5.70	5.75	5.81	5.87	100
110	5.92	5.97	6.03	6.08	6.14	6.19	6.25	6.30	6.36	6.42	110
120	6.47	6.53	6.58	6.64	6.69	6.75	6.81	6.85	6.92	6.97	120
130	7.03	7.09	7.14	7.20	7.25	7.31	7.37	7.42	7.48	7.53	130

DIN43710-1977

Units : mV

Temperature (°C)	0	1	2	3	4	5	6	7	8	9	Temperature (°C)
140	7.59	7.65	7.70	7.76	7.81	7.87	7.93	7.98	8.04	8.09	140
150	8.15	8.21	8.26	8.32	8.37	8.43	8.49	8.54	8.60	8.65	150
160	8.71	8.77	8.82	8.88	8.93	8.99	9.05	9.10	9.16	9.21	160
170	9.27	9.33	9.38	9.44	9.49	9.55	9.61	9.66	9.72	9.77	170
180	9.83	9.89	9.94	10.00	10.05	10.11	10.17	10.22	10.28	10.33	180
190	10.39	10.45	10.50	10.56	10.61	10.67	10.73	10.78	10.84	10.89	190
200	10.95	11.01	11.06	11.12	11.17	11.23	11.29	11.34	11.40	11.45	200
210	11.51	11.57	11.62	11.68	11.73	11.79	11.85	11.90	11.96	12.01	210
220	12.07	12.13	12.18	12.24	12.29	12.35	12.41	12.46	12.52	12.57	220
230	12.63	12.69	12.74	12.80	12.85	12.91	12.97	13.02	13.08	13.13	230
240	13.19	13.25	13.30	13.36	13.41	13.47	13.53	13.58	13.64	13.69	240
250	13.75	13.81	13.86	13.92	13.97	14.03	14.09	14.14	14.20	14.25	250
260	14.31	14.37	14.42	14.48	14.54	14.59	14.65	14.71	14.76	14.82	260
270	14.88	14.94	14.99	15.05	15.10	15.16	15.22	15.27	15.33	15.38	270
280	15.44	15.50	15.55	15.61	15.66	15.72	15.78	15.83	15.89	15.94	280
290	16.00	16.06	16.11	16.17	16.22	16.28	16.34	16.39	16.45	16.50	290
300	16.56	16.62	16.67	16.73	16.78	16.84	16.90	16.95	17.01	17.06	300
310	17.12	17.18	17.23	17.29	17.34	17.40	17.46	17.51	17.57	17.62	310
320	17.68	17.74	17.79	17.85	17.90	17.96	18.02	18.07	18.13	18.18	320
330	18.24	18.30	18.35	18.41	18.46	18.52	18.58	18.63	18.69	18.74	330
340	18.80	18.86	18.91	18.97	19.02	19.08	10.14	19.19	19.25	19.30	340
350	19.36	19.42	19.47	19.53	19.58	19.64	19.70	19.75	19.81	19.85	350
360	19.92	19.98	20.03	20.09	20.14	20.20	20.26	20.31	20.37	20.42	360
370	20.48	20.54	20.59	20.65	20.70	20.76	20.82	20.87	20.93	20.98	370
380	21.04	21.10	21.15	21.21	21.26	21.32	21.38	21.43	21.49	21.54	380
390	21.60	21.66	21.71	21.77	21.82	21.88	21.94	21.99	22.05	22.10	390
400	22.16	22.22	22.27	22.33	22.38	22.44	22.50	22.55	22.61	22.66	400
410	22.72	22.78	22.83	22.89	22.95	23.00	23.06	23.12	23.18	23.23	410
420	23.29	23.35	23.40	23.46	23.52	23.57	23.63	23.69	23.74	23.80	420
430	23.86	23.92	23.97	24.03	24.09	24.14	24.20	24.26	24.32	24.37	430
440	24.43	24.49	24.54	24.60	24.66	24.71	24.77	24.83	24.89	24.94	440
450	25.00	25.06	25.11	25.17	25.23	25.28	25.34	25.40	25.46	25.51	450
460	25.57	25.63	25.68	25.74	25.80	25.85	25.91	25.97	26.03	26.08	460
470	26.14	26.20	26.25	26.31	26.37	26.42	26.48	26.54	26.60	26.65	470

# APPENDICES

## Type Fe-CuNi

DIN43710-1977

Units : mV

Temperature (°C)	0	1	2	3	4	5	6	7	8	9	Temperature (°C)
480	26.71	26.77	26.82	26.88	26.94	26.99	27.05	27.11	27.17	27.22	480
490	27.28	27.34	27.39	27.45	27.51	27.56	27.62	27.68	27.74	27.79	490
500	27.85	27.91	27.97	28.02	28.08	28.14	28.20	28.26	28.31	28.37	500
510	28.43	28.49	28.55	28.60	28.66	28.72	28.78	28.84	28.89	28.95	510
520	29.01	29.07	29.13	29.18	29.24	29.30	29.36	29.42	29.47	29.53	520
530	29.59	29.65	29.71	29.76	29.82	29.88	29.94	30.00	30.05	30.11	530
540	30.17	30.23	30.29	30.34	30.40	30.46	30.52	30.58	30.63	30.69	540
550	30.75	30.81	30.87	30.92	30.98	31.04	31.10	31.16	31.21	31.27	550
560	31.33	31.39	31.45	31.50	31.56	31.62	31.68	31.74	31.79	31.85	560
570	31.91	31.97	32.03	32.08	32.14	32.20	32.26	32.32	32.37	32.43	570
580	32.49	32.55	32.61	32.66	32.72	32.78	32.84	32.90	32.96	33.02	580
590	33.08	33.14	33.20	33.26	33.32	33.38	33.43	33.49	33.55	33.61	590
600	33.67	33.73	33.79	33.85	33.91	33.97	34.02	34.08	34.14	34.20	600
610	34.26	34.32	34.38	34.44	34.50	34.56	34.61	34.67	34.73	34.79	610
620	34.85	34.91	34.97	35.03	35.09	35.15	35.20	35.26	35.32	35.38	620
630	35.44	35.50	35.56	35.62	35.68	35.74	35.80	35.86	35.92	35.98	630
640	36.04	36.10	36.16	36.22	36.28	36.34	36.40	36.46	36.52	36.58	640
650	36.64	36.70	36.76	36.82	36.88	36.95	37.01	37.07	37.13	37.19	650
660	37.25	37.30	37.36	37.42	37.48	37.55	37.61	37.67	37.73	37.79	660
670	37.85	37.91	37.97	38.04	38.10	38.16	38.22	38.28	38.35	38.41	670
680	38.47	38.53	38.59	38.66	38.72	38.78	38.84	38.90	38.97	39.03	680
690	39.09	39.15	39.22	39.28	39.34	39.41	39.47	39.53	39.59	39.66	690
700	39.72	39.78	39.85	39.91	39.97	40.04	40.10	40.16	40.22	40.29	700
710	40.35	40.41	40.48	40.54	40.60	40.67	40.73	40.80	40.86	40.93	710
720	40.98	41.04	41.11	41.17	41.23	41.30	41.36	41.43	41.49	41.56	720
730	41.62	41.69	41.75	41.82	41.88	41.95	42.01	42.08	42.14	42.21	730
740	42.27	42.34	42.40	42.47	42.53	42.60	42.66	42.73	42.79	42.86	740
750	42.92	42.99	43.05	43.12	43.18	43.25	43.31	43.38	43.44	43.51	750
760	43.57	43.64	43.70	43.77	43.83	43.90	43.97	44.03	44.10	44.16	760
770	44.23	44.30	44.36	44.43	44.49	44.56	44.63	44.69	44.76	44.82	770
780	44.89	44.96	45.02	45.09	45.15	45.22	45.29	45.35	45.42	45.48	780
790	45.55	45.62	45.68	45.75	45.82	45.89	45.95	46.02	46.09	46.15	790
800	46.22	46.29	46.35	46.42	46.49	46.56	46.62	46.69	46.76	46.82	800
810	46.89	46.96	47.03	47.09	47.16	47.23	47.30	47.37	47.43	47.50	810
820	47.57	47.64	47.71	47.77	47.84	47.91	47.98	48.05	48.11	48.18	820

# APPENDICES

## Type Fe-CuNi

DIN43710-1977

Units : mV

Temperature (°C)	0	1	2	3	4	5	6	7	8	9	Temperature (°C)
830	48.25	48.32	48.39	48.46	48.53	48.60	48.66	48.73	48.80	48.87	830
840	48.94	49.01	49.08	49.15	49.22	49.29	49.35	49.42	49.49	49.56	840
850	49.63	49.70	49.77	49.84	49.91	49.98	50.04	50.11	50.18	50.25	850
860	50.32	50.39	50.46	50.53	50.60	50.67	50.74	50.81	50.88	50.95	860
870	51.02	51.09	51.16	51.23	51.30	51.37	51.44	51.51	51.58	51.65	870
880	51.72	51.79	51.86	51.93	52.00	52.08	52.15	52.22	52.29	52.36	880
890	52.43	52.50	52.57	52.64	52.71	52.79	52.86	52.93	53.00	53.07	890
900	53.14										900

**3.9 Standard thermoelectromotive force tables for type Cu-CuNi thermocouples**

DIN43710-1977

Units : mV

Temperature (°C)	0	1	2	3	4	5	6	7	8	9	Temperature (°C)
-200	-5.70										-200
-190	-5.51	-5.53	-5.55	-5.57	-5.59	-5.60	-5.62	-5.64	-5.66	-5.68	-190
-180	-5.32	-5.34	-5.36	-5.38	-5.40	-5.41	-5.43	-5.45	-5.47	-5.49	-180
-170	-5.12	-5.14	-5.16	-5.18	-5.20	-5.22	-5.24	-5.26	-5.28	-5.30	-170
-160	-4.91	-4.93	-4.95	-4.97	-4.99	-5.02	-5.04	-5.06	-5.08	-5.10	-160
-150	-4.69	-4.71	-4.73	-4.76	-4.78	-4.80	-4.82	-4.84	-4.87	-4.89	-150
-140	-4.46	-4.48	-4.51	-4.53	-4.55	-4.58	-4.60	-4.62	-4.64	-4.67	-140
-130	-4.21	-4.23	-4.26	-4.28	-4.31	-4.33	-4.36	-4.38	-4.41	-4.43	-130
-120	-3.95	-3.98	-4.00	-4.03	-4.05	-4.08	-4.11	-4.13	-4.16	-4.18	-120
-110	-3.68	-3.71	-3.73	-3.76	-3.79	-3.81	-3.84	-3.87	-3.90	-3.92	-110
-100	-3.40	-3.43	-3.46	-3.48	-3.51	-3.54	-3.57	-3.60	-3.62	-3.65	-100
-90	-3.11	-3.14	-3.17	-3.20	-3.23	-3.25	-3.28	-3.31	-3.34	-3.37	-90
-80	-2.81	-2.84	-2.87	-2.90	-2.93	-2.96	-2.99	-3.02	-3.05	-3.08	-80
-70	-2.50	-2.53	-2.58	-2.59	-2.62	-2.66	-2.69	-2.72	-2.75	-2.78	-70
-60	-2.18	-2.21	-2.24	-2.28	-2.31	-2.34	-2.37	-2.40	-2.44	-2.47	-60
-50	-1.85	-1.88	-1.92	-1.95	-1.98	-2.02	-2.05	-2.08	-2.11	-2.15	-50
-40	-1.50	-1.53	-1.57	-1.60	-1.64	-1.67	-1.71	-1.74	-1.78	-1.81	-40
-30	-1.14	-1.18	-1.21	-1.25	-1.28	-1.32	-1.36	-1.39	-1.43	-1.46	-30
-20	-0.77	-0.81	-0.84	-0.88	-0.92	-0.95	-0.99	-1.03	-1.07	-1.10	-20
-10	-0.39	-0.43	-0.47	-0.50	-0.54	-0.58	-0.62	-0.66	-0.69	-0.73	-10
-0	0.00	-0.04	-0.08	-0.12	-0.16	-0.19	-0.23	-0.27	-0.31	-0.35	-0
0	0.00	0.04	0.08	0.12	0.16	0.20	0.24	0.28	0.32	0.36	0
10	0.40	0.44	0.48	0.52	0.56	0.60	0.64	0.68	0.72	0.76	10
20	0.80	0.84	0.88	0.92	0.96	1.00	1.05	1.09	1.13	1.17	20
30	1.21	1.25	1.29	1.34	1.38	1.42	1.46	1.50	1.55	1.59	30
40	1.63	1.67	1.71	1.76	1.80	1.84	1.88	1.92	1.97	2.01	40
50	2.05	2.09	2.14	2.18	2.22	2.26	2.31	2.35	2.39	2.44	50
60	2.48	2.52	2.57	2.61	2.65	2.69	2.74	2.78	2.82	2.87	60
70	2.91	2.95	3.00	3.04	3.09	3.13	3.17	3.22	3.26	3.31	70
80	3.35	3.39	3.44	3.48	3.53	3.57	3.62	3.66	3.71	3.75	80
90	3.80	3.84	3.89	3.93	3.98	4.02	4.07	4.11	4.16	4.20	90
100	4.25	4.30	4.34	4.39	4.43	4.48	4.53	4.57	4.62	4.66	100
110	4.71	4.76	4.80	4.85	4.90	4.94	4.99	5.04	5.09	5.13	110
120	5.18	5.23	5.27	5.32	5.37	5.41	5.46	5.51	5.56	5.60	120
130	5.65	5.70	5.75	5.79	5.84	5.89	5.94	5.99	6.03	6.08	130

# APPENDICES

## Type Cu-CuNi

DIN43710-1977

Units : mV

Temperature (°C)	0	1	2	3	4	5	6	7	8	9	Temperature (°C)
140	6.13	6.18	6.23	6.28	6.33	6.37	6.42	6.47	6.52	6.57	140
150	6.62	6.67	6.72	6.77	6.82	6.87	6.92	6.97	7.02	7.07	150
160	7.12	7.17	7.22	7.27	7.33	7.37	7.43	7.48	7.53	7.58	160
170	7.63	7.68	7.73	7.79	7.84	7.89	7.94	7.99	8.05	8.10	170
180	8.15	8.20	8.25	8.31	8.36	8.41	8.46	8.51	8.57	8.62	180
190	8.67	8.72	8.78	8.83	8.88	8.93	8.99	9.04	9.09	9.15	190
200	9.20	9.25	9.31	9.36	9.42	9.47	9.52	9.58	9.63	9.69	200
210	9.74	9.79	9.85	9.90	9.96	10.01	10.07	10.12	10.18	10.23	210
220	10.29	10.35	10.40	10.46	10.51	10.57	10.62	10.68	10.74	10.79	220
230	10.85	10.91	10.96	11.02	11.07	11.13	11.19	11.24	11.30	11.35	230
240	11.41	11.47	11.52	11.58	11.64	11.69	11.75	11.81	11.87	11.92	240
250	11.98	12.04	12.09	12.15	12.21	12.26	12.32	12.38	12.44	12.49	250
260	12.55	12.61	12.67	12.72	12.78	12.84	12.90	12.96	13.01	13.07	260
270	13.13	13.19	13.25	13.30	13.36	13.42	13.48	13.54	13.59	13.65	270
280	13.71	13.77	13.83	13.89	13.95	14.00	14.06	14.12	14.18	14.24	280
290	14.30	14.36	14.42	14.48	14.54	14.60	14.66	14.72	14.78	14.84	290
300	14.90	14.96	15.02	15.08	15.14	15.20	15.26	15.32	15.38	15.44	300
310	15.50	15.56	15.62	15.68	15.74	15.80	15.86	15.92	15.98	16.04	310
320	16.10	16.16	16.22	16.28	16.34	16.40	16.46	16.52	16.58	16.64	320
330	16.70	16.76	16.82	16.88	16.94	17.00	17.07	17.13	17.19	17.24	330
340	17.31	17.37	17.43	17.49	17.55	17.61	17.68	17.74	17.80	17.86	340
350	17.92	17.98	18.04	18.10	18.16	18.22	18.29	18.35	18.41	18.47	350
360	18.53	18.59	18.65	18.71	18.77	18.83	18.89	18.96	19.02	19.08	360
370	19.14	19.20	19.26	19.33	19.39	19.45	19.51	19.57	19.64	19.70	370
380	19.76	19.82	19.89	19.95	20.01	20.07	20.13	20.19	20.26	20.32	380
390	20.38	20.44	20.50	20.57	20.63	20.69	20.75	20.81	20.88	20.94	390
400	21.00	21.06	21.12	21.19	21.25	21.31	21.37	21.43	21.50	21.56	400
410	21.62	21.68	21.75	21.81	21.87	21.93	22.00	22.06	22.12	22.19	410
420	22.25	22.31	22.38	22.44	22.50	22.56	22.63	22.69	22.75	22.82	420
430	22.88	22.94	23.01	23.07	23.13	23.19	23.26	23.32	23.38	23.45	430
440	23.51	23.57	23.64	23.70	23.77	23.83	23.89	23.96	24.02	24.09	440
450	24.15	24.21	24.28	24.34	24.41	24.47	24.53	24.60	24.66	24.73	450
460	24.79	24.85	24.92	24.98	25.05	25.11	25.18	25.24	25.31	25.37	460
470	25.44	25.50	25.57	25.63	25.70	25.76	25.83	25.89	25.95	26.02	470
480	26.09	26.16	26.22	26.29	26.35	26.42	26.49	26.55	26.62	26.68	480
490	26.75	26.82	26.88	26.95	27.01	27.08	27.15	27.21	27.28	27.34	490
500	27.41	27.48	27.54	27.61	27.68	27.74	27.81	27.88	27.95	28.01	500
510	28.08	28.15	28.21	28.28	28.35	28.41	28.48	28.55	28.62	28.68	510
520	28.75	28.82	28.89	28.95	29.02	29.09	29.16	29.23	29.29	29.36	520
530	29.43	29.50	29.57	29.63	29.70	29.77	29.84	29.91	29.97	30.04	530
540	30.11	30.18	30.25	30.32	30.39	30.45	30.52	30.59	30.66	30.73	540
550	30.80	30.87	30.94	31.01	31.08	31.14	31.21	31.28	31.35	31.42	550
560	31.49	31.56	31.63	31.70	31.77	31.84	31.91	31.98	32.05	32.12	560
570	32.19	32.26	32.33	32.40	32.47	32.54	32.61	32.68	32.75	32.82	570
580	32.89	32.96	33.03	33.10	33.17	33.24	33.32	33.39	33.46	33.53	580
590	33.60	33.67	33.74	33.81	33.88	33.95	34.03	34.10	34.17	34.24	590
600	34.31										600



# APPENDICES

## Appendix 4 A616TD Dimensions

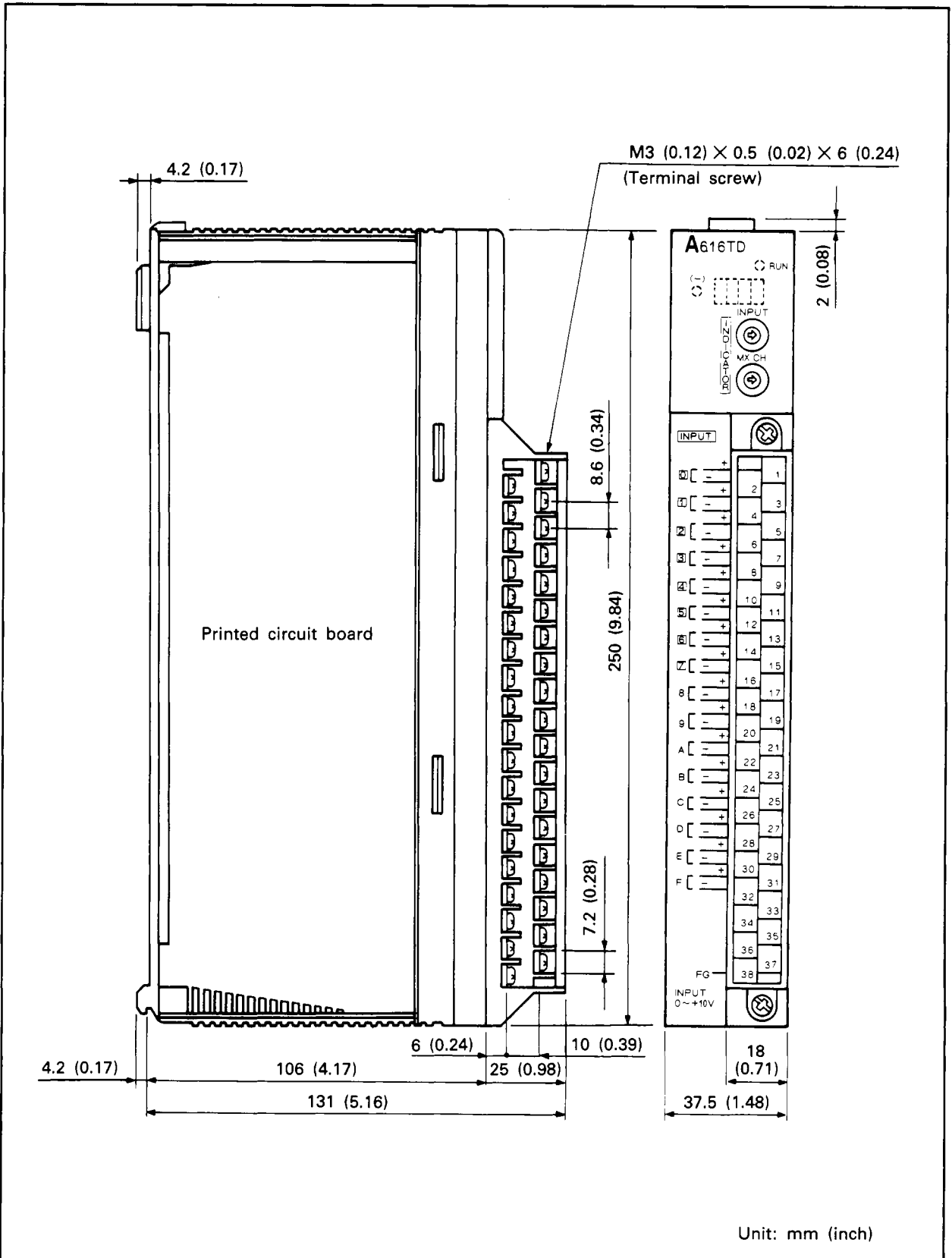

# APPENDICES

## Appendix 5 A60MXT Dimensions

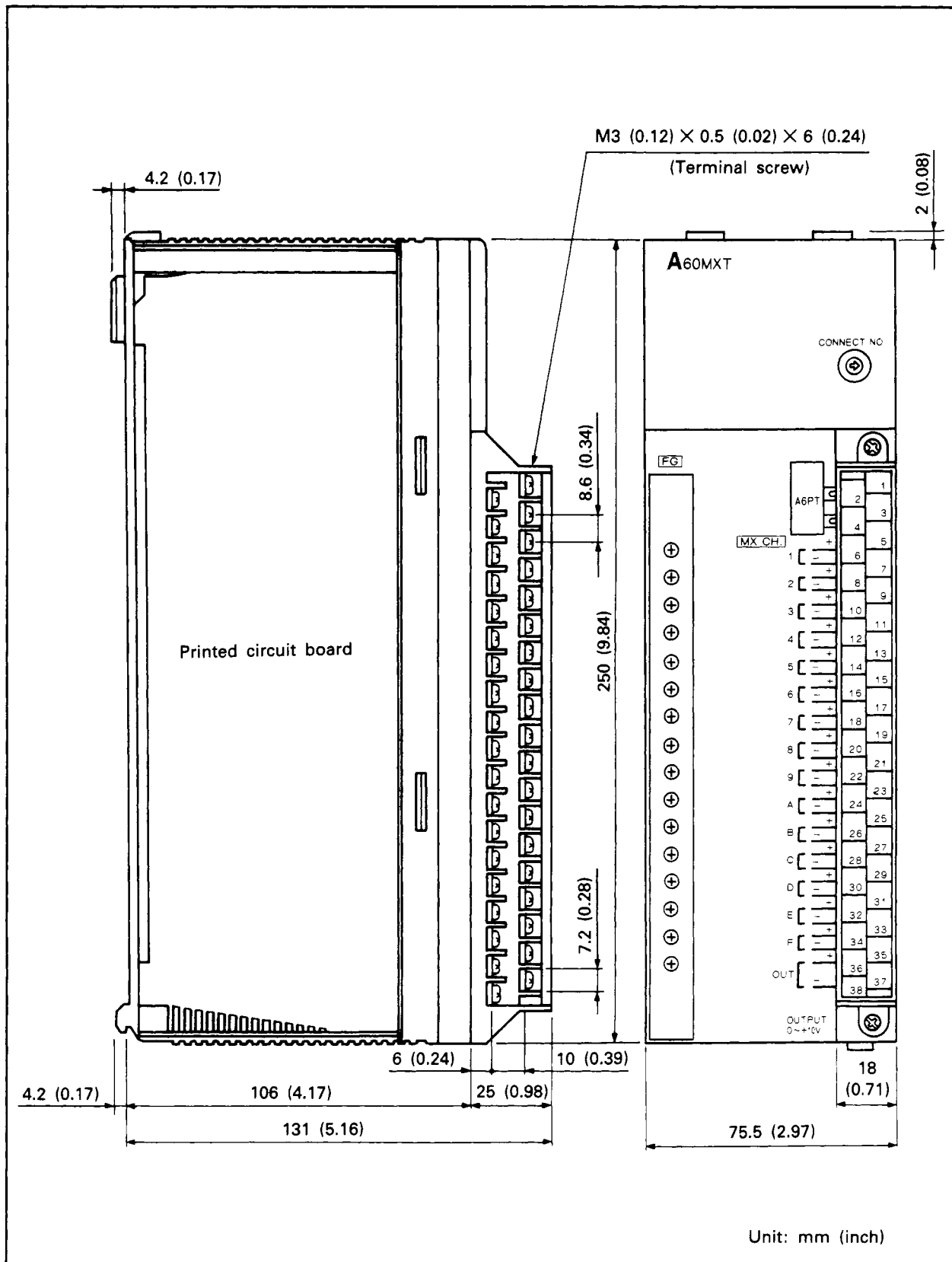

# APPENDICES

## Appendix 6 A60MX/A60MXR Dimensions

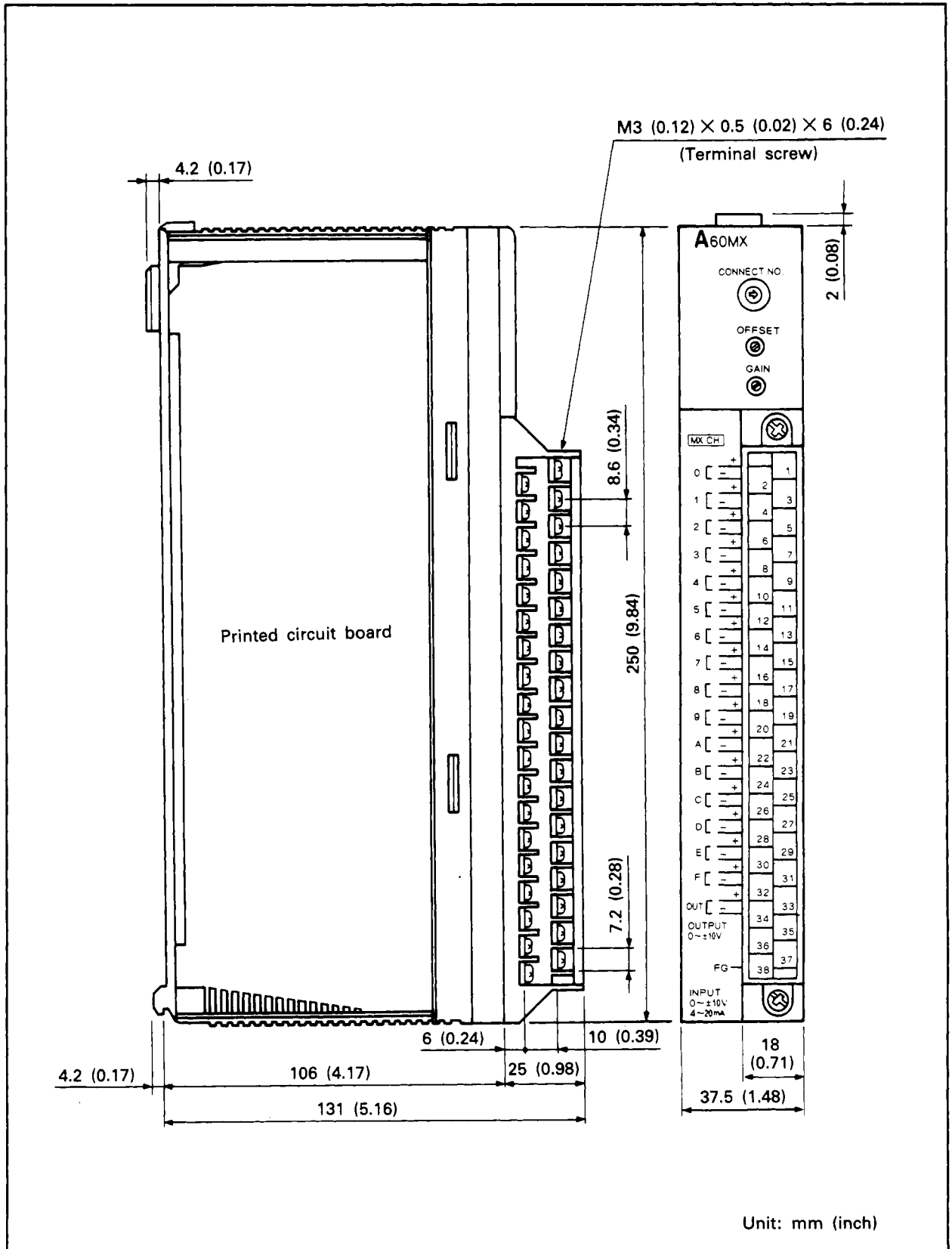

**IMPORTANT**

**The components on the printed circuit boards will be damaged by static electricity, so avoid handling them directly. If it is necessary to handle them take the following precautions.**

- (1) Ground human body and work bench.**
- (2) Do not touch the conductive areas of the printed circuit board and its electrical parts with any non-grounded tools etc.**

Under no circumstances will Mitsubishi Electric be liable or responsible for any consequential damage that may arise as a result of the installation or use of this equipment.

All examples and diagrams shown in this manual are intended only as an aid to understanding the text, not to guarantee operation. Mitsubishi Electric will accept no responsibility for actual use of the product based on these illustrative examples.

Owing to the very great variety in possible applications of this equipment, you must satisfy yourself as to its suitability for your specific application.

 **MITSUBISHI ELECTRIC SALES AMERICA, INC.**

Industrial Automation Division

---

Mount Prospect, IL 60056